

Title: sPHS (super PHS) Specifications
Version: 01
Date: October 5, 2010
XGP Forum Classification: Unrestricted
List of contents: Abbreviations and Acronyms. Chapter 0 Scope and Introduction. Chapter 1 General Chapter 2 System Overview.. Chapter 3 Physical Channel Specification. Chapter 4 Individual Channel Specification. Chapter 5 Common Channel Specification. Chapter 6 Channel Assignment Chapter 7 Message Format and Information Elements. Chapter 8 Sequence. Chapter 9 Access Phase. Appendix A: Full Subcarrier Mode. Appendix B: Modulation. Appendix C: Training Sequence. Appendix D: TCCH Sequence.
Number of pages: 411

XGP Forum

c/o Association of Radio Industries and Businesses (ARIB)
11F, Nittochi Bldg., 4-1, Kasumigaseki 1-choume, Chiyoda-ku, Tokyo 100-0013, Japan
TEL +81-3-5510-8599 FAX +81-3-3592-1103

© XGP Forum2010

History of Revised Versions/Revisions

Version	Revision	Date	Outline
01	01	October 5, 2010	Approved by Letter Voting. Established

Remarks

1. The definition.

1.1. Version:

A major change such as changing of basic specifications or adding new sections that would be unable to achieve only with existing technologies, or methods written into the former version. The change made to a new version shall only be authorized by General Meeting.

1.2. Revision:

A minor change such as partial changing, or adding some words which shall not affect the basics. The change made to a new revision shall be authorized by each WG, and reported to the latest General Meeting.

2. Copyright Notice.

XGP Forum reserves all rights concerning the copyright to this document. The XGP Forum reserves the right to modify or amend this document in its own discretion without notice.

3. IPR Policy.

This document adopts fully the IPR policy of XGP Forum specified separately on its website.

4. Limitation of Liability

NOTHING IN THIS DOCUMENT CREATES ANY WARRANTIES OF TITLE OR NONINFRINGEMENT WITH RESPECT TO ANY TECHNOLOGIES, STANDARDS OR SPECIFICATIONS REFERENCED OR INCORPORATED INTO THIS DOCUMENT.

IN NO EVENT SHALL THE XGP FORUM OR ANY MEMBER BE LIABLE TO THE USER OR TO A THIRD PARTY FOR ANY CLAIM ARISING FROM OR RELATING TO THE USE OF THIS DOCUMENT, INCLUDING, WITHOUT LIMITATION, A CLAIM THAT SUCH USE INFRINGES A THIRD PARTY'S INTELLECTUAL PROPERTY RIGHTS OR THAT IT FAILS TO COMPLY WITH APPLICABLE LAWS OR REGULATIONS. BY USE OF THIS DOCUMENT, THE USER WAIVES ANY SUCH CLAIM AGAINST THE XGP FORUM AND ITS MEMBERS RELATING TO THE USE OF THIS DOCUMENT.

Abbreviations and Acronyms	1
Chapter 0 Scope and Introduction	4
Scope.....	4
Introduction.....	4
Chapter 1 General	6
1.1 Overview.....	6
1.2 Application Scope	6
1.3 Mandatory and Optional	7
Chapter 2 System Overview	8
2.1 System Structure	8
2.1.1 Mobile Station (MS).....	8
2.1.2 Base Station (BS).....	8
2.1.3 Relay Station (RS).....	8
2.2 Interface Definition.....	9
2.3 Frequency Structure	10
2.3.1 System Bandwidth (SBW)	10
2.3.2 Effective Channel Bandwidth (ECBW)	10
2.3.3 Guard Bandwidth (GBW).....	10
2.3.4 Frequency Structure Parameters	10
2.4 Access Method	11
2.4.1 Transmission Method	11
2.4.2 TDMA (Time Division Multiple Access)	12
2.4.3 OFDMA (Orthogonal Frequency Division Multiple Access).....	13
2.4.4 OFDMA and TDMA	15
2.4.5 Single Carrier Frequency Division Multiple Access (SC-FDMA) Mode Coexistence with OFDMA UL	16
2.5 Physical Resource Unit (PRU).....	17
2.6 Frame Structure.....	18
2.7 Full Subcarrier Mode	19
2.8 Multiple Input and Multiple Output Control.....	19
2.9 Protocol Model.....	19
2.9.1 Link Establishment Phase	19
2.9.2 Access Establishment Phase	19
2.9.3 Access Phase.....	20
2.10 Correspondence of PRU, Function Channel and Physical Channel.....	20
2.11 Service Description.....	22
2.12 Protocol Structure.....	22
Chapter 3 Physical Channel Specification	24

3.1 Overview.....	24
3.2 The General Conditions for OFDM PHY Layer.....	24
3.2.1 OFDM Burst Structure.....	24
3.2.2 OFDM Symbol Structure.....	25
3.2.3 OFDM Parameters.....	28
3.3 The General Conditions for SC PHY Layer.....	29
3.3.1 SC Burst Structure.....	29
3.3.2 SC Block Structure.....	29
3.3.3 SC Parameters.....	31
3.4 DL OFDM PHY Layer.....	32
3.4.1 Channel Coding for PHY Frame.....	32
3.4.2 Training Format for DL OFDM.....	54
3.4.3 Pilot for DL OFDM.....	56
3.4.4 Signal for DL OFDM.....	57
3.4.5 Null (DTX/DC Carrier/Guard carrier) for DL OFDM.....	58
3.4.6 TCCH Format for DL OFDM.....	59
3.4.7 PRU Structure for DL OFDM.....	60
3.5 UL OFDM PHY Layer.....	67
3.5.1 Channel Coding for PHY Frame.....	67
3.5.2 Training for UL OFDM.....	68
3.5.3 Pilot for UL OFDM.....	68
3.5.4 Signal for UL OFDM.....	68
3.5.5 Null (DTX/DC Carrier/Guard Carrier) for UL OFDM.....	68
3.5.6 TCCH Format for UL OFDM.....	68
3.5.7 PRU Structure for UL OFDM.....	72
3.6 UL SC PHY Layer.....	72
3.6.1 Channel Coding for PHY Frame.....	72
3.6.2 Training for UL SC.....	88
3.6.3 Pilot for UL SC.....	90
3.6.4 Signal for UL SC.....	92
3.6.5 TCCH for UL SC.....	94
3.6.6 SC Burst Structure for UL SC.....	95
Chapter 4 Individual Channel Specification.....	104
4.1 Overview.....	104
4.1.1 Usage of PRU.....	104
4.1.2 QoS Class (Access Mode).....	106
4.1.3 sPHS Protocol Outline.....	107
4.2 Functional Channel.....	109

4.2.1 Channel Composition	109
4.3 PHY Layer Structure and Frame Format	111
4.3.1 PHY Frame Structure	111
4.3.2 Signal Symbol	115
4.3.3 PHY Header	115
4.3.4 PHY Payload	119
4.3.5 PHY Trailer	120
4.3.6 PHY Control Layer	120
4.3.7 Summary of PHY Frame Format	142
4.4 MAC Layer Structure and Frame Format	143
4.4.1 Overview	143
4.4.2 MAC Frame Format	144
4.4.3 Segmentation, Combining and Concatenation	155
4.4.4 MAC Control Layer	161
Chapter 5 Common Channel Specification	167
5.1 Overview	167
5.2 Common Channel (CCH)	167
5.2.1 Logical Common Channel (LCCH)	169
5.2.2 Definition of Superframe	170
5.2.3 Superframe Structure of DL LCCH	170
5.2.4 Structure of UL LCCH	173
5.2.5 Structure of DL LCCH	173
5.2.6 LCCH Multiplexing	174
5.3 PHY Frame Format	176
5.3.1 BCCH	176
5.3.2 PCH	177
5.3.3 TCCH	177
5.3.4 SCCH	177
5.4 Control Field Format	178
5.4.1 Channel Identifier (CI)	178
5.4.2 BS Information (BS-Info)	179
5.4.3 Common Control Information (CCI)	181
5.4.4 Mobile Station ID (MSID)	181
5.5 MSG Field	182
5.5.1 Message Type List	182
5.5.2 MSG (BCCH)	183
5.5.3 MSG (PCH)	194
5.5.4 MSG (SCCH)	213

Chapter 6 Channel Assignment	238
6.1 Overview	238
6.2 Link Establishment Control	238
6.3 Channel Assignment Control	240
6.4 Connection Control	241
6.4.1 FM-Mode	241
6.4.2 QS-Mode	247
6.5 Radio State Management	248
6.5.1 Idle State	248
6.5.2 Active State	249
6.5.3 Sleep State	251
6.6 Summary of Parameters	251
Chapter 7 Message Format and Information Elements	253
7.1 Overview	253
7.2 Message Format	253
7.2.1 Format Regulations	253
7.2.2 Message Type	254
7.3 Information Element Format	271
7.3.1 Format Regulations	271
7.3.2 Single Octet Information Element Identifier	272
7.3.3 Multiple Octet Information Element Identifier	276
7.3.4 Information Element Rules	316
Chapter 8 Sequence	319
8.1 Overview	319
8.2 Sequence	319
8.2.1 Outgoing Call	319
8.2.2 Incoming Call	321
8.2.3 Release	323
8.2.4 Location Registration	325
8.2.5 ANCH/CSCH Switching	327
8.2.6 Handover	330
8.2.7 Link Channel Establishment	336
8.2.8 Additional QCS	338
8.2.9 Status Check	341
8.2.10 CQI Transmission	342
Chapter 9 Access Phase	344
9.1 Overview	344
9.2 Retransmission Control Method	344

9.2.1 ARQ.....	344
9.2.2 HARQ.....	347
9.3 QCS and Connection.....	358
9.3.1 Service Class	358
9.3.2 QoS Parameter	359
9.4 Access Phase Control	361
9.4.1 Power Control.....	361
9.4.2 Timing Control.....	362
9.4.3 Link Adaptation Control.....	363
9.4.4 ANCH/CSCH Scheduling Control.....	365
9.4.5 Interference Avoidance Control.....	367
9.4.6 Handover Control	372
9.5 MAC Layer Control	374
9.5.1 Window Control	374
9.5.2 Flow Control	376
9.5.3 Retransmission Control by SR Method	377
9.5.4 Notification and Recovery of Error Condition	380
9.6 Encryption Field.....	381
Appendix A: Full Subcarrier Mode	382
A.1 Overview	382
A.2 Definition of Full Subcarrier Mode	382
Appendix B: Modulation	383
B.1 BPSK.....	383
B.2 $\pi/2$ - BPSK.....	384
B.3 QPSK	385
B.4 $\pi/4$ - QPSK.....	386
B.5 8PSK	387
B.6 16QAM	388
B.7 64QAM	390
B.8 256QAM	393
B.9 16PSK	399
Appendix C: Training Sequence	400
C.1 OFDM Training Sequence	400
C.2 SC Training Sequence	405
Appendix D: TCCH Sequence	410
D.1 OFDM TCCH Sequence	410
D.2 SC TCCH sequence.....	411

Abbreviations and Acronyms

AAA	Authentication, Authorization, Accounting
AAS	Adaptive array Antenna System
ACCH	Accompanied Control Channel
ACK	Acknowledgment
al-VRC	allowable Packet loss and Variable Rate Class
ANCH	Anchor Channel
BCCH	Broadcast Control Channel
BER	Bit Error Rate
BPSK	Binary Phase Shift Keying
BS	Base Station
BSID	BS Identification
CC	Convolutional Code
CCH	Common Channel
CCCH	Common Control Channel
CC-HARQ	Chase Combining -HARQ
CCI	Common Control Information
CDCH	CSCH Data Channel
CI	Channel Identifier
CQI	Channel Quality Indicator
CRC	Cyclic Redundancy Code
CSCH	Circuit Switching Channel
DTX	Discontinuous Transmission
DL	DownLink
ECBW	Effective Channel Bandwidth
ECCH	EXCH Control Channel
EDCH	EXCH Data Channel
EXCH	Extra Channel
FER	Frame Error Rate
FFT	Fast Fourier Transform
FM-Mode	Fast access channel based on MAP -Mode
FRMR	Frame Reject
GBW	Guard Bandwidth
GI	Guard Interval
HARQ	Hybrid Automatic Repeat Request
HC	HARQ Cancel
HLR	Home Location Register
IBI	Inter-Block Interference
ICCH	Individual Control Channel
ICH	Individual Channel
ICI	Inter-Carrier Interference
IFFT	Inverse Fast Fourier Transform
IL	Information Link bit
IP	Internet Protocol
IR-HARQ	Incremental Redundancy -HARQ
ISI	Inter-Symbol Interference
LAC	Leave Alone Class

LCH	Link Channel
LCCH	Logical Common Channel
LD-BE	Low - Delay Best Effort Class
LDPC	Low Density Parity Check
LPF	Low Pass Filter
LSB	Least Significant Bit
MAC	Media Access Control
MCS	Modulation and Coding Scheme
MI	MCS Indicator
MIMO	Multiple Input Multiple Output
MM	Mobility Management
MR	MCS Request
MS	Mobile Station
MSB	Most Significant Bit
MSID	MS Identification
NACK	Negative ACK
nl-VRC	no Packet loss and Variable Rate Class
OFDMA	Orthogonal Frequency Division Multiple Access
PAD	Padding
PAPR	Peak to Average Power Ratio
PC	Power Control
PCH	Paging Channel
PHY	Physical layer
PLC	Private Line Class
PN	Pseudo Noise
PRU	Physical Resource Unit
QAM	Quadrature Amplitude Modulation
QCS	QoS Control Session
QoS	Quality of Service
QPSK	Quadrature Phase Shift Keying
QS-Mode	high Quality channel based on carrier Sensing -Mode
RAN	Radio Access Network
RCH	Request Channel
REJ	Reject
RIL	Remaining Information Length indication bit
RNR	Receive Not Ready
RR	Receive Ready
RROF	Root Roll-Off Filter
RS	Relay Station
RSSI	Received Signal Strength Indicator/Indication
RT	Radio frequency Transmission management
SBW	System Bandwidth
SC	Single Carrier
SCCH	Signaling Control Channel
SC-FDMA	Single Carrier Frequency Division Multiple Access
SCH	Subchannel
SD	Shift Direction
SINR	Signal to Interference and Noise Ratio
sPHS	Super PHS

SR	Selective Repeat
SREJ	Selective Reject
TCCH	Timing Correct Channel
TCH	Traffic Channel
TDD	Time Division Duplex
TDMA	Time Division Multiple Access
UL	UpLink
V	Validity
VoIP	Voice over IP
VRC	Variable Rate Class

Chapter 0 Scope and Introduction

Scope

This standard is being established principally for "Super PHS (sPHS)". PHS means Personal Handy phone System. In order to ensure the fairness and the openness among all parties involved in developing this system, the radio equipment manufacturers, telecommunications operators and the users were invited openly to the Standard Assembly so as to gain this standard with the total agreement of all parties involved in developing standard.

The scope of application of this standard covers the minimum requirements for the service and communication provided by this system.

This standard of sPHS is promoted by the XGP Forum, which was established in 1995; for the purpose of expanding PHS service to all over the world.

Introduction

sPHS is one of the future mobile communication systems, which will realize the higher call traffic and high speed data communication at the same time. This "sPHS standard" shows the developed future status of "Original PHS standard". The description for this system will be added to "Original PHS standard" in order to develop "sPHS standard".

Original PHS is the standard of Association of Radio Industries and Business (ARIB), which has been standardized since 1993. The sPHS standard is in compliance with ARIB standards too. However, to apply it as an international convention, the standard is also adopted by XGP Forum.

sPHS will support all the services that Original PHS is now supplying. It will also display further technical potentiality for subscribers to enjoy better services that might be requested by future PHS users.

Especially, the major expanded features of "sPHS" which is aimed to realize are as follows.

- Expanded function variety and performance of Original PHS.
- Co-existence with Original PHS
- Higher capacity for call traffic and data traffic density
- Flexibility for cell mapping for various cell types
- Higher capability for mobility service

sPHS is constructed on the same mobile communication structure as Original PHS. It is absolutely possible to operate Original PHS and sPHS in the co-existing network and to supply both services within the same area.

The concept of co-existence situation is shown in Figure 0. The MS for Original PHS can make communication to Original PHS and Dual type Base Station (BS). The Mobile Station (MS) for sPHS can make communication to sPHS and Dual type BS. The Dual type MS can make communication to all kinds of BS. It is possible for both systems to be on service in the same network.

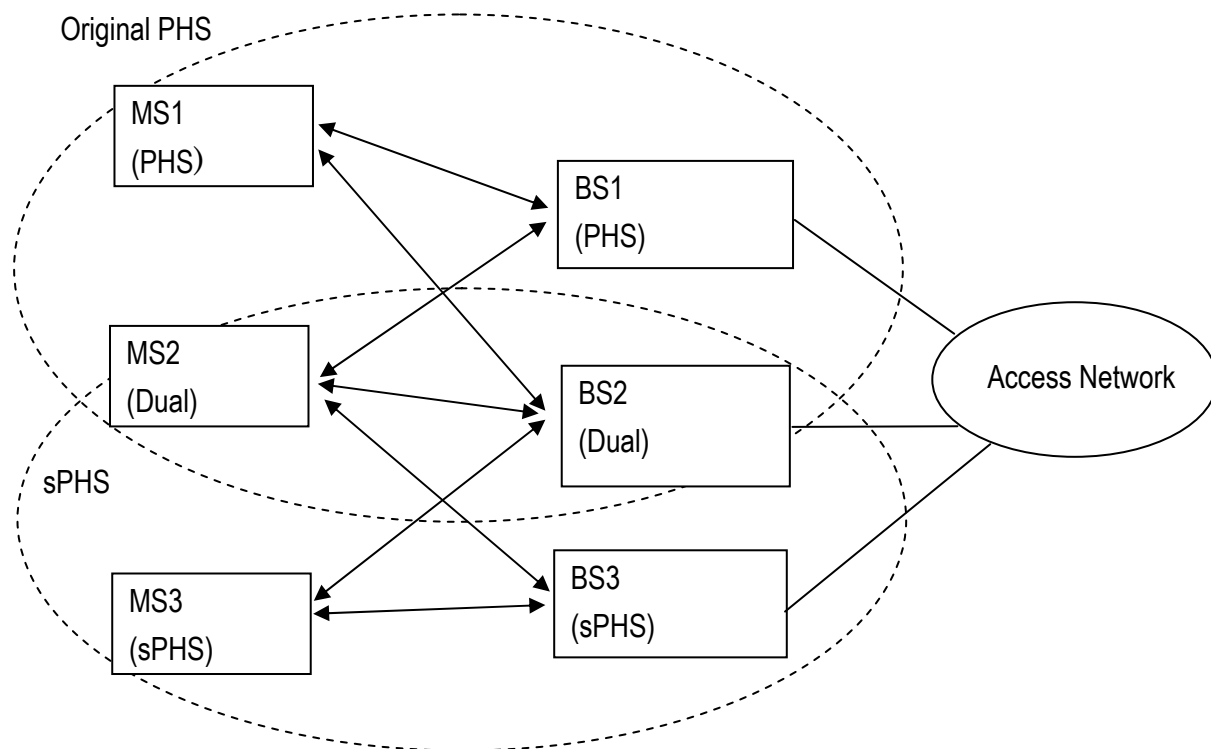

MS: Mobile Station
 BS: Base Station
 PHS: Original PHS
 sPHS: Super PHS
 Dual: Hybrid of Original PHS and Super PHS

Figure 0 Concept of Co-existence with Original PHS

Chapter 1 General

1.1 Overview

The standard is provided to specify the radio interface of communication systems that performs sPHS.

1.2 Application Scope

sPHS is composed of MS, BS and Relay Station (RS) (radio stations which relay communication between BS and MS) shown in Figure 1.1.

This standard specifies the radio interface between BS and MS, as shown in Figure 1.1, for sPHS.

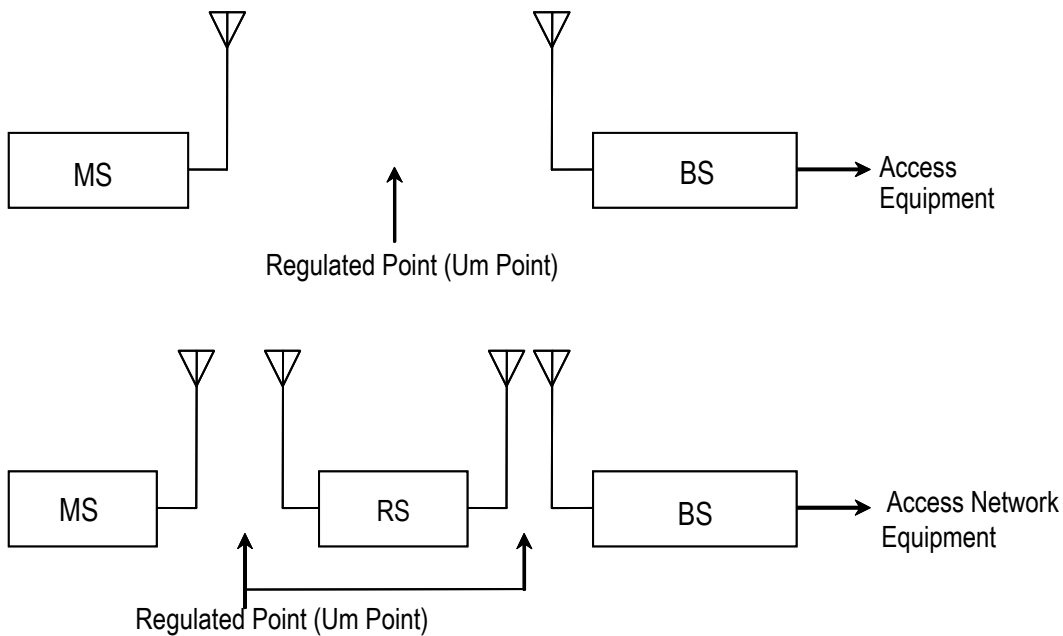

Figure 1.1 Structure of sPHS

1.3 Mandatory and Optional

This standard includes both mandatory and optional descriptions.

The items necessary for system interface are defined as mandatory, and the items that depend on the manufacture are defined as optional.

Chapter 2 System Overview

2.1 System Structure

sPHS consists of MS, BS and Relay Station which relays communications between BS and MS (hereinafter, referred to as RS).

2.1.1 Mobile Station (MS)

A mobile station is used to make mobile radio communication to either mobile station or base station.

A mobile station consists of radio equipment with antenna, transmitter and receiver; interface to external equipments, voice encoding equipment, control equipment, and a sending/receiving handset etc.

In addition, the terminal, such as personal computer, can be connected to the MS if needed.

2.1.2 Base Station (BS)

A base station carries out mobile radio communication with mobile stations.

A base station consists of radio equipment with antenna, transmitter and receiver and control equipment.

2.1.3 Relay Station (RS)

A relay station relays mobile radio communication between BS and MS. The detail specification of RS will be defined in the future.

Counterpart of relay station to BS or MS consists of radio equipment with antenna, transmitter and receiver and control equipment.

2.2 Interface Definition

There is "Um" interface point for sPHS, as shown in Figure 2.1.

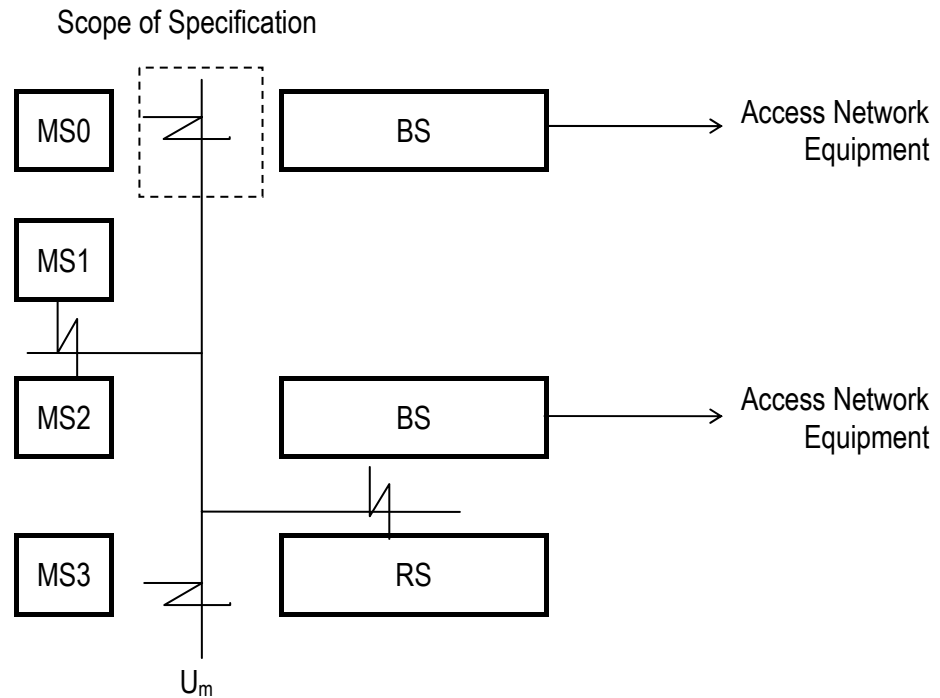

- Um Point : Interface point between MS and BS, interface point between RS and BS or MS, or interface point between MS and MS.

- MS0, MS1, MS2, MS3 : MS, including integrated man/machine interface with terminals etc.

Figure 2.1 Interface Points

2.3 Frequency Structure

Figure 2.2 shows relation among system bandwidth, effective channel bandwidth and guard bandwidth.

See more details in the following sections.

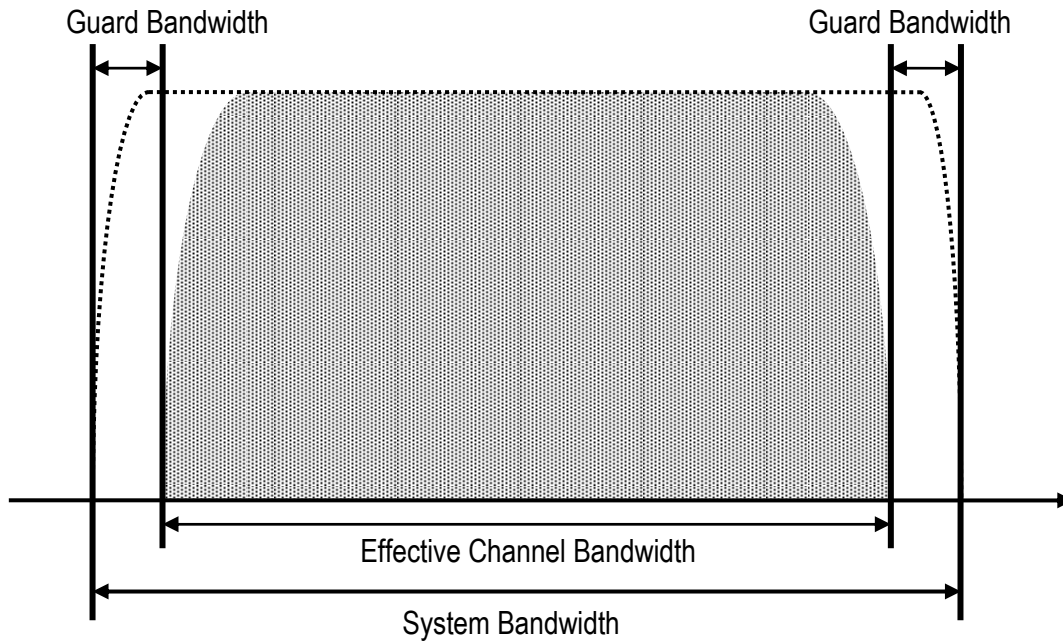

Figure 2.2 Frequency Structure

2.3.1 System Bandwidth (SBW)

System bandwidth is defined as total bandwidth including guard bandwidth and effective channel bandwidth and can be chosen from 2.4MHz.

2.3.2 Effective Channel Bandwidth (ECBW)

Effective channel bandwidth is defined as the bandwidth excluding guard bandwidth from system bandwidth. One or more users can exist in this bandwidth.

2.3.3 Guard Bandwidth (GBW)

Guard bandwidth is defined as the bandwidth to prevent interference into/from the adjacent system.

The structure in frequency domain for sPHS is shown in Figure 2.2. Half of GBW is set to each side of frequency that is either lower or higher than ECBW.

2.3.4 Frequency Structure Parameters

Summary of actual values which is explained in Section 2.3 is shown in Table 2.1.

Table 2.1 Frequency Structure Parameters

System Bandwidth [MHz]		2.4
Effective Channel Bandwidth [MHz]		1.8
Guard Bandwidth [MHz]		0.6
Frequency Division Multiple Access Method	Downlink (DL)	OFDMA
	Uplink (UL)	OFDMA/SC-FDMA

2.4 Access Method

The access method of DL for sPHS is OFDMA/TDMA-TDD.

The access method of UL for sPHS is OFDMA/TDMA-TDD or SC-FDMA/TDMA-TDD.

TDD frame period is 5 ms, which is the same as Original PHS.

The transmission for four slots and the reception for four slots are repeated.

Each slot time is 625 us and TDMA access, and is operated by single carrier for Original PHS. sPHS has the same frame format as Original PHS, and adopts the OFDMA for frequency division multiple access.

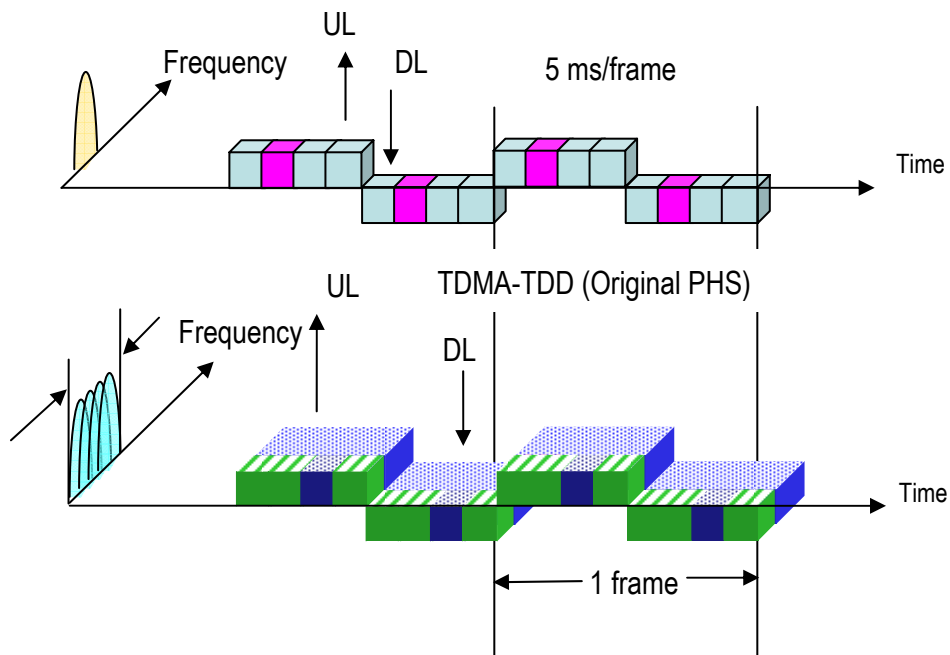

Figure 2.3 OFDMA/SC-FDMA/TDMA-TDD (sPHS)

2.4.1 Transmission Method

The basic configurations for sPHS are shown in Table 2.2.

Table 2.2 Basic Configuration of sPHS

Basic Configuration	Contents
Duplex Method	TDD
DL Access Method	OFDMA/TDMA
UL Access Method	OFDMA, SC-FDMA/TDMA
TDMA Frame Period	5 ms
Number of Slots in One Frame	8 slots, 4 slots for transmission and 4 slots for reception symmetrically
Number of Subchannels	2 subchannels in 2.4 MHz system bandwidth

Refer to Sections 2.4.2, 2.4.2.1 and 2.4.2.2 for TDMA slot and TDMA frame.
Refer to Section 2.4.3.2 for subchannel.

2.4.2 TDMA (Time Division Multiple Access)

Figure 2.4 shows an example of TDMA slot arrangement in the light of appropriate sending/receiving slot separation in TDD transmission.

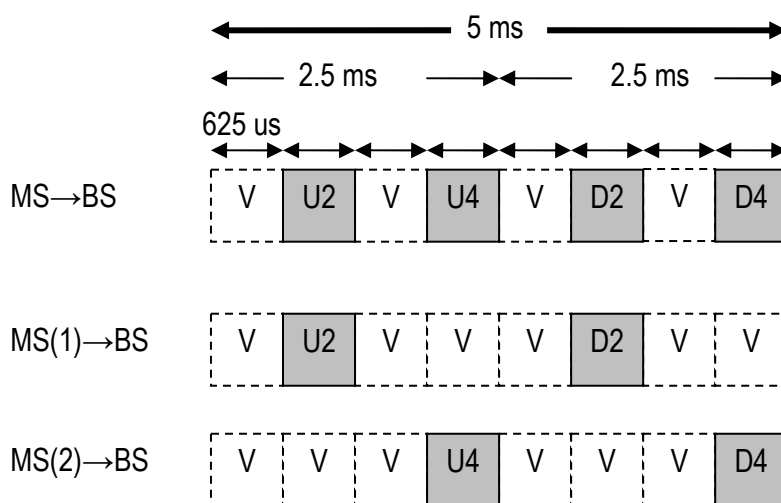

U: UL, D : DL, V : Vacant
U_i - D_i : Corresponding UL / DL slot

Figure 2.4 TDMA Slot Arrangement

2.4.2.1 TDMA Slot

A slot is a minimum unit that composes TDMA, and its period is 625 us. This period is the same as Original PHS.

2.4.2.2 TDMA Frame

A frame is composed of eight slots. Four slots (2.5 ms) are sending slots and other four slots are receiving slots. The period of one frame is 5 ms. These parameters are the same as Original PHS. Transmission burst lengths tolerance is less than or equal to +5us/+5us, and greater than or equal to -30us/-50us for BS/MS.

2.4.3 OFDMA (Orthogonal Frequency Division Multiple Access)

Figure 2.5 shows the OFDMA subchannel structure.

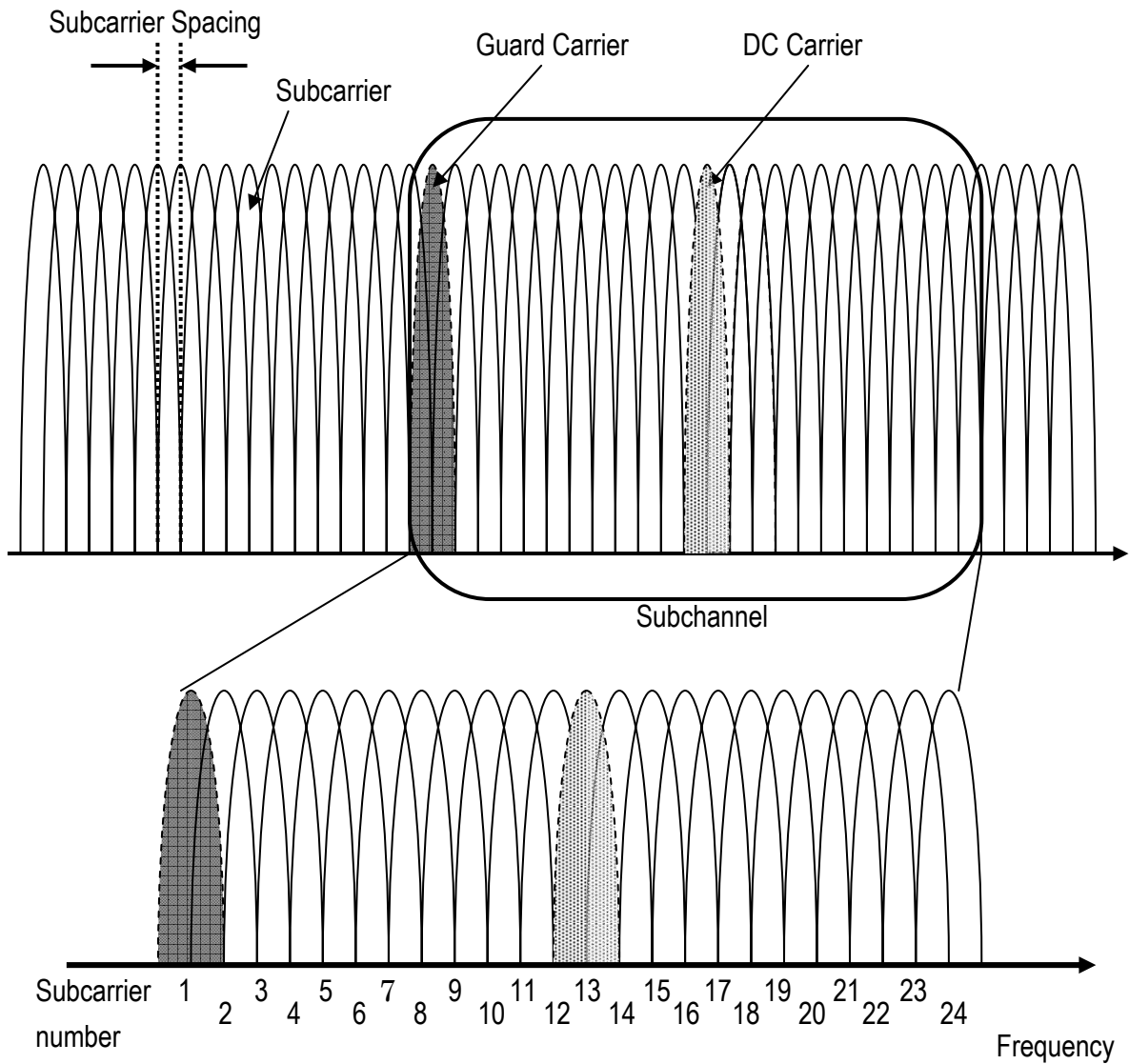

Figure 2.5 OFDMA Structure

Figure 2.6 shows an example of OFDMA subchannel arrangement for a specific sending/receiving slot in which multiple access is realized in frequency domain.

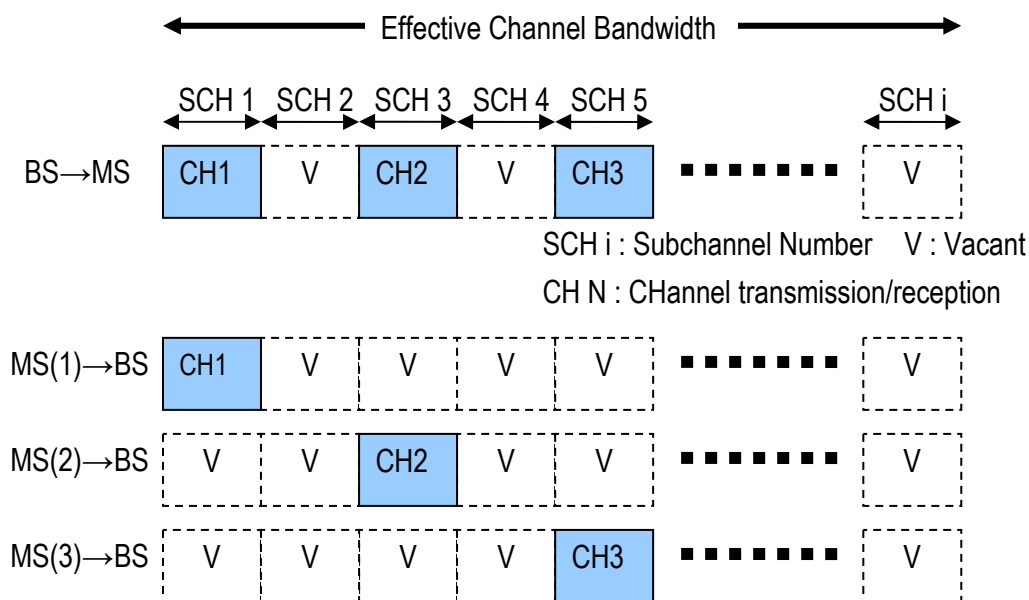

Figure 2.6 OFDMA Frequency Arrangement

2.4.3.1 Subcarrier Spacing

Subcarrier is defined as a “carrier” of OFDM in sPHS.

In addition, plural subcarriers can be used as one block at the same time.

Subcarrier spacing is defined at 37.5 kHz as a space between neighboring subcarriers.

2.4.3.2 Subchannel (SCH)

Subchannel is defined as a group of subcarriers with 900 kHz bandwidth. Subchannel is composed of 24 subcarriers. The lowest frequency subcarrier included in one subchannel is defined as subcarrier No. 1. The highest frequency subcarrier included in one subchannel is defined as subcarrier No. 24. Figure 2.7 shows subchannel number in each ECBW.

SBW = 2.4 MHz, ECBW = 1.8 MHz

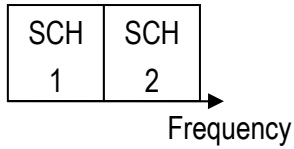

Figure 2.7 Definition of Subchannel Number in each ECBW

2.4.3.3 DC Carrier

DC carrier is not used for data transmission. When one subchannel is in use, DC carrier is set at subcarrier No. 13 as shown in Figure 2.5. The way to set DC carrier for the improvement of data throughput is described in Section 2.7.

2.4.3.4 Guard Carrier

To avoid the interference between subcarriers used by different MS, the guard carrier is not used for data transmission. Guard carrier insertion depends on the DL/UL subchannel format. When one subchannel is in use, guard carrier is set at subcarrier No. 1 as shown in Figure 2.5. The way to set guard carrier for the improvement of data throughput is described in Section 2.7.

2.4.4 OFDMA and TDMA

This sPHS allows both frequency division multiple access and time division multiple access. Figure 2.8 shows the example of the combination of OFDMA/TDMA access. The detail of channel assignment is defined in 0.

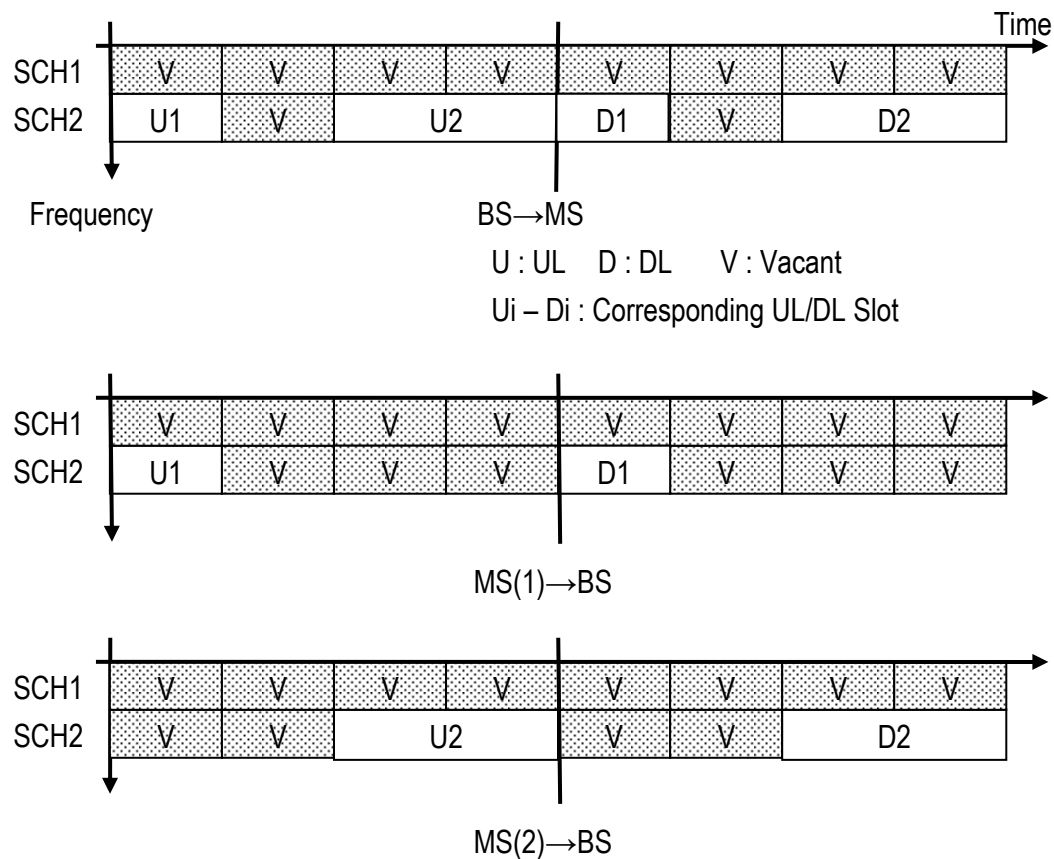

Figure 2.8 OFDMA/TDMA Slot Arrangement

2.4.5 Single Carrier Frequency Division Multiple Access (SC-FDMA) Mode Coexistence with OFDMA UL

sPHS has SC-FDMA mode in UL, and allows the coexistence of SC-FDMA and OFDMA. Figure 2.9 shows the example of the combination of OFDMA and SC-FDMA UL access.

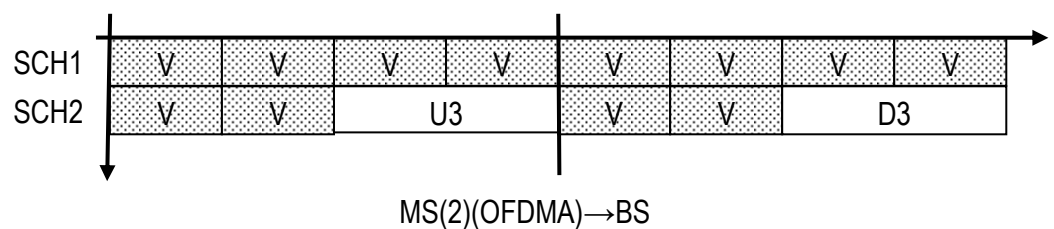
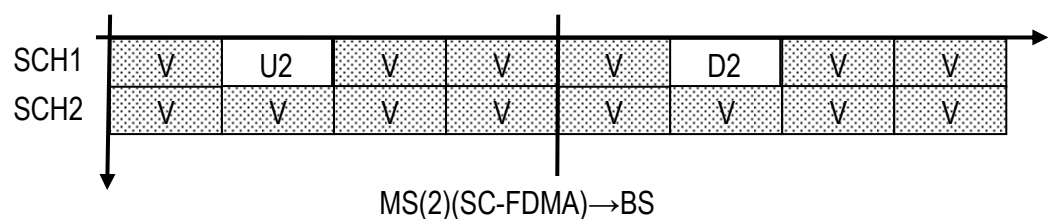
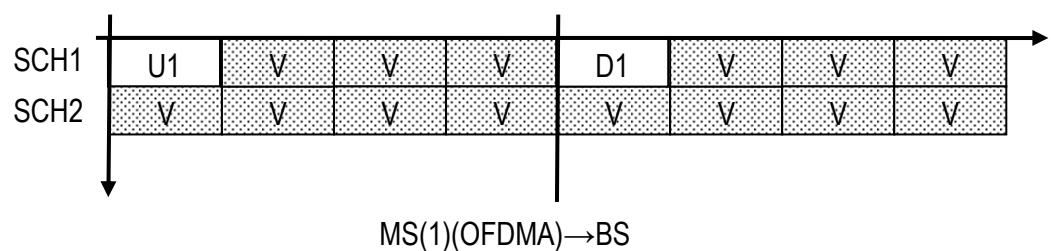
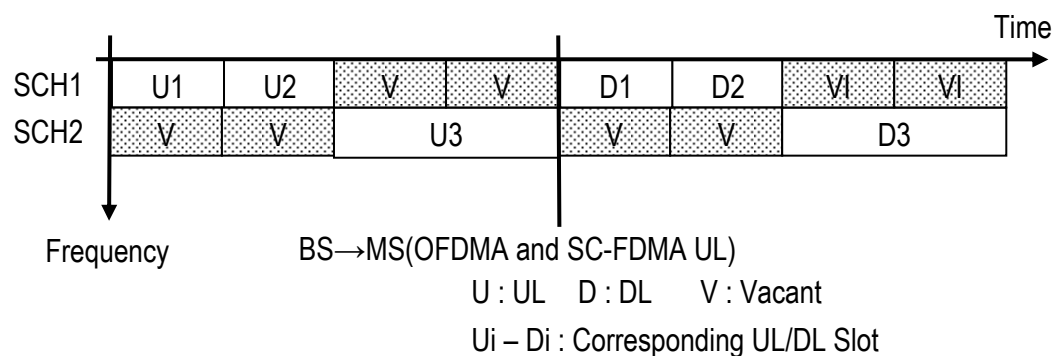

Figure 2.9 OFDMA and SC-FDMA Slot Arrangement

2.5 Physical Resource Unit (PRU)

The word PRU defined in sPHS stands for a block divided by the time axis unit (TDMA slot 625 us) and the frequency axis unit (OFDM subchannel 900 kHz). Figure 2.10 shows the

correspondence between subchannel number and PRU number.

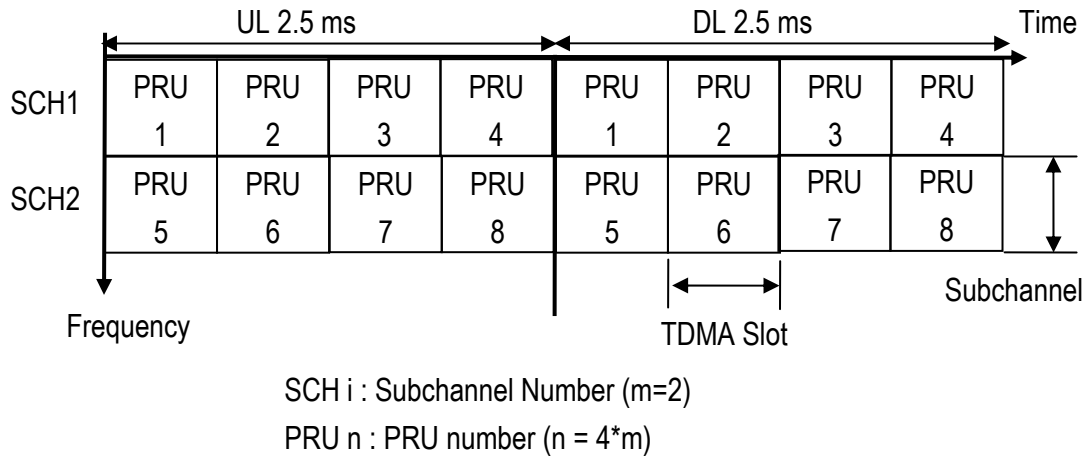

Figure 2.10 Correspondence between Subchannel Number and PRU Number

Table 2.3 PRU

System Bandwidth [MHz]	2.4
Effective Channel Bandwidth [MHz]	1.8
Subchannel Bandwidth [kHz]	900
Number of Subchannels	2
Total Number of PRU	8
TDMA Slot Period [us]	625

2.6 Frame Structure

Figure 2.11 shows the frame structure in each ECBW.

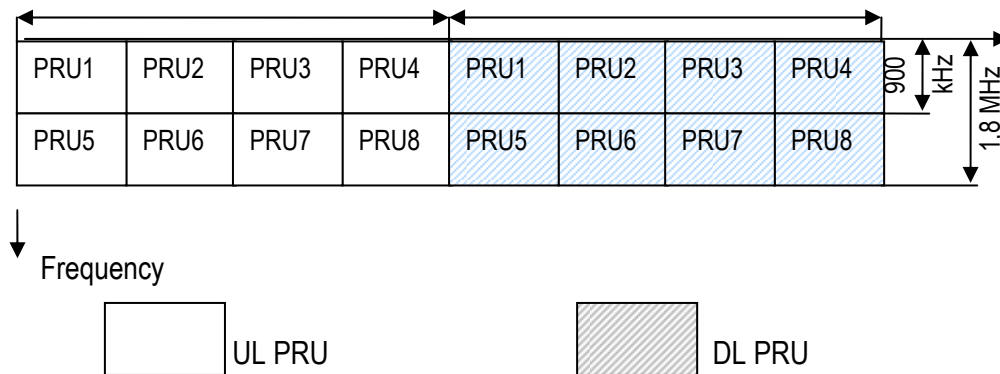

Figure 2.11 Frame Structure

2.7 Full Subcarrier Mode

Full subcarrier mode is optional and is used only in DL. When full subcarrier mode is used, all of DC carriers and guard carriers except central subcarrier are replaced with data symbols. Details are described in Appendix A.

2.8 Multiple Input and Multiple Output Control

Multiple Input and Multiple Output (MIMO), compared with Single Input and Single Output (SISO), is a technique to increase the data throughput without additional bandwidth. MIMO transfers multiple data streams in parallel by using multiple antennas at the transmitter and receiver. This function is assumed to be defined in the future.

2.9 Protocol Model

Protocol model is composed of link establishment phase, access establishment phase and access phase.

2.9.1 Link Establishment Phase

Link establishment phase is defined as the stage to use common channel (CCH) functions to select the protocol type required in the next phase.

2.9.2 Access Establishment Phase

Access establishment phase is defined as the stage to use functions which is obtained in the link establishment phase to select the protocol type required in the next phase.

2.9.3 Access Phase

In the access phase, it is possible to employ the optimum channel and the optimum protocol for each service.

2.10 Correspondence of PRU, Function Channel and Physical Channel

Figure 2.12 shows function channel classification.

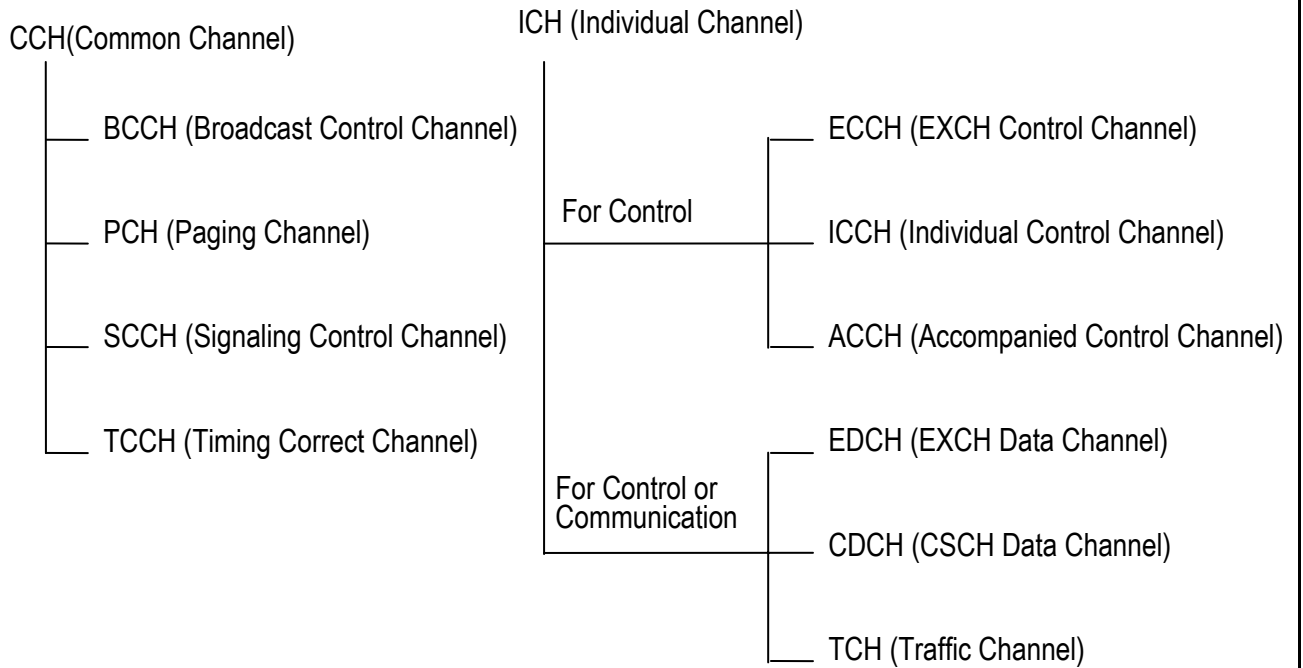

Figure 2.12 Function Channel Classification

Table 2.4 explains function channel.

Table 2.4 Function Channel Description

	Channel Name	Function Description
CCH	BCCH	BCCH is a DL channel to broadcast the control information from BS to MS.
	PCH	PCH is a DL channel to inform the paging information from BS to MS.
	SCCH	SCCH is both DL and UL channel for LCH assignment. DL SCCH notifies allocation of an individual channel to MS. And, UL SCCH requests LCH re-assignment to BS.
	TCCH	TCCH is an UL channel to detect UL transmission timing. Also, MS requires LCH establishment using TCCH.
ICH	ECCH	UL/DL bidirectional control channel which put into ANCH. It has some information to control channel allocation, modulation method, transmission power and timing and others for EXCH.
	ICCH	UL/DL bidirectional control channel which put into ANCH. It transmits the signaling message.
	ACCH	UL/DL bidirectional control channel which accompanies TCH in CSCH. It transmits the signaling message.
	EDCH	UL/DL bidirectional channel which put into EXCH. It transmits user traffic data or the signaling message.
	CDCH	UL/DL bidirectional channel which put into allocated CSCH. It transmits user traffic data or the signaling message.
	TCH	UL/DL bidirectional channel which put into CSCH. It transmits user traffic data.

Figure 2.13 shows the correspondence of between PHY PRU and function channel in each protocol phase.

PRU		Protocol Phase	Link Establishment Phase	Access Establishment Phase	Access Phase
		UL	SCCH TCCH		
DL	BCCH PCH SCCH				
ICH			ICCH	ECCH ICCH ACCH EDCH CDCH TCH	

Figure 2.13 Correspondence between PHY PRU and Function Channel in Each Protocol Phase

2.11 Service Description

sPHS provides various wireless telecommunication services. There are not only bearer of voice but also packet data communication such as VoIP, Video-phone, Streaming and Multi-cast service. The services are based on a network constructed with IP etc, and providing packet transporter for air-interface.

2.12 Protocol Structure

The protocol structure of sPHS is shown in Figure 2.14. The protocol layer between MS and BS consists of PHY and MAC layer.

PHY layer controls physical wireless line between MS and BS. It defines the modulation method, physical frame format etc. The details are described in Chapter 3.

MAC layer controls link establishment, channel assignment, channel quality maintenance etc. The detail function is described in Chapter 4 and 5.

The upper network layer is based on IP protocols etc. This document complies with the specification of PHY and MAC layer between MS and BS.

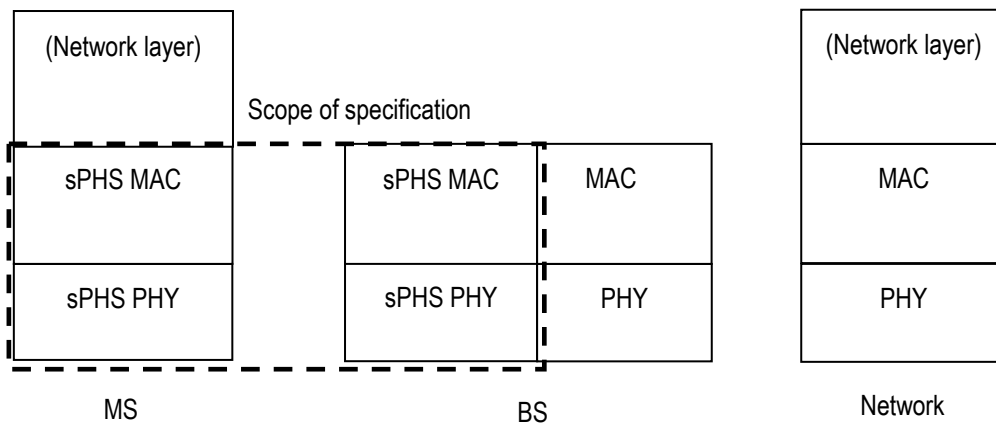

Figure 2.14 Protocol Stack for sPHS

Chapter 3 Physical Channel Specification

3.1 Overview

This chapter describes the technical requirements applied to radio transmission facilities for sPHS.

The following physical (PHY) layer specification is designed to satisfy the functional requirements that have been defined for sPHS. It incorporates many aspects of existing standards in order to ensure reliable operation in the targeted 1 GHz to 3 GHz frequency band.

The DL PHY layer described in this chapter is based on Time Division Multiple Access (TDMA) and Orthogonal Frequency Division Multiple Access (OFDMA) modulation. The general condition of OFDM PHY layer is described in Section 3.2. The details of the DL PHY layer are described in Section 3.4.

The UL PHY layer described in this chapter is based on TDMA and OFDMA modulation or TDMA and Single-Carrier Frequency Division Multiple Access (SC-FDMA) modulation. UL PHY layer in compliance with this standard shall support at least either OFDMA or SC-FDMA. The general condition of SC PHY layer is described in Section 3.3. The detail of the UL OFDM PHY layer is described in Section 3.5. The details of the UL SC PHY layer are described in Section 3.6.

Physical channel is composed of two channels - Common Channel (CCH) and Individual Channel (ICH). CCH is composed of two channels - Common Control Channel (CCCH) and Timing Correct Channel (TCCH). ICH is composed of three channels - Anchor Channel (ANCH), Extra Channel (EXCH) and Circuit Switching Channel (CSCH). CCCH format is described in Sections 3.4.7.1.1, 3.5.7.1.1 and 3.6.6.1.1. TCCH format is described in Sections 3.5.7.1.2 and 3.6.6.1.2. ANCH is described in Sections 3.4.7.2.1, 3.5.7.2.1 and 3.6.6.2.1. EXCH format is described in Sections 3.4.7.2.2, 3.5.7.2.2 and 3.6.6.2.2. CSCH format is described in Sections 3.4.7.2.3, 3.5.7.2.3 and 3.6.6.2.3. The detail of ICH is described in Chapter 4. The detail of CCH is described in Chapter 5.

Subcarrier spacing in frequency is dictated by the multipath characteristics of the channels in which sPHS is designated to operate. As the channel propagation characteristics depend on the topography of the area and on the cell radius, the amount of carriers into which the channels are subdivided depends on the overall channel width and the carrier spacing. This PHY layer specification contains the programmability to deal with this range of applications.

3.2 The General Conditions for OFDM PHY Layer

3.2.1 OFDM Burst Structure

Figure 3.1 describes a frame structure for OFDM transmission method. As shown in the figure, OFDM burst consists of 19 OFDM symbols and OFDM burst length is defined as 573.33 μ s and 580 μ s in one slot of UL and DL, respectively. Guard time is the time between the OFDM burst and subsequent OFDM burst. And the total guard time length is defined as 51.67 μ s and 45 μ s in one slot. For OFDM, a modulated symbol is mapped and then is sent in each subcarrier. In one frame, several units of data are processed in symbols.

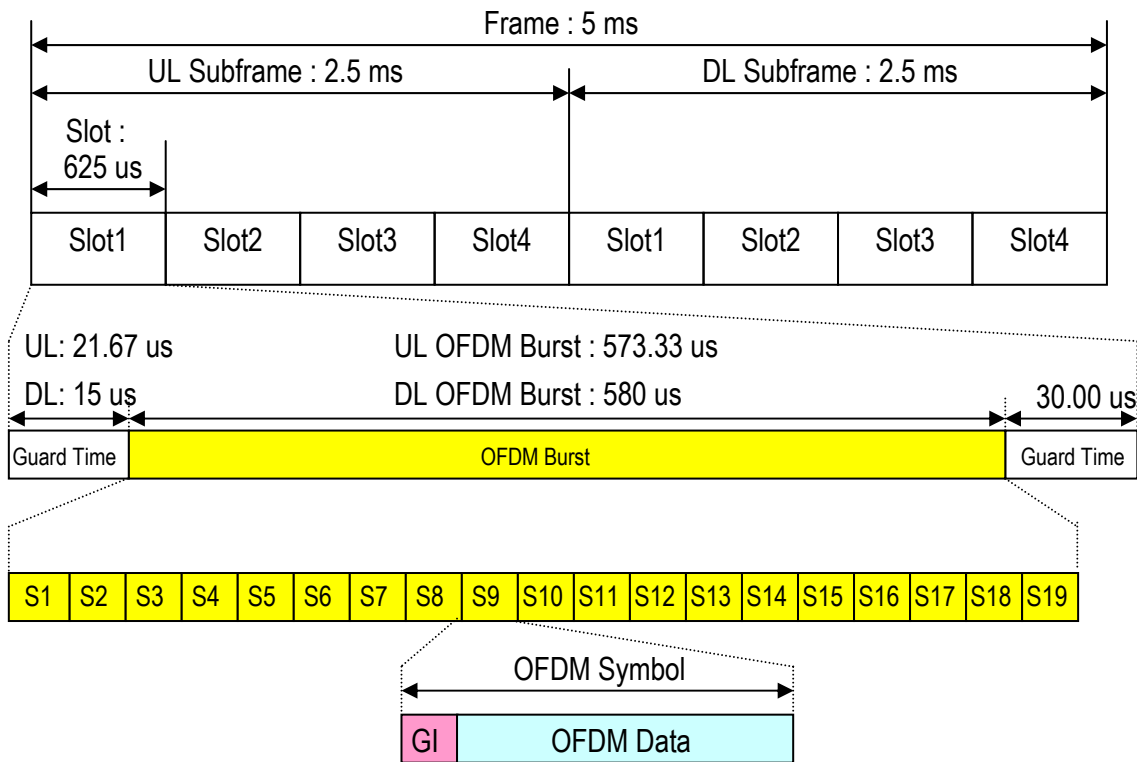

Figure 3.1 OFDM Symbols

3.2.2 OFDM Symbol Structure

OFDM symbol is composed of OFDM data and Guard Interval (GI) as shown in Figure 3.2. OFDM data length is defined as the reciprocal of subcarrier spacing and is 26.67 us. GI is described in Section 3.2.2.1. There are two OFDM symbol lengths in one OFDM burst. The first OFDM symbol (S1) length is defined as 33.33 and 40 us for DL and UL, respectively. Other symbols (S2-S19) length is defined as 30 us.

3.2.2.1 Guard Interval

Guard Interval (GI) is defined as a time interval between OFDM symbols in order to avoid the interference caused by delay spread. GI is the cyclic extension of the OFDM symbols itself. In addition, the guard interval ratio is defined as the ratio of Data length and guard interval length. As shown in Figure 3.2, GI for the first OFDM symbol (S1) in UL and DL is defined as 6.66 us and 13.33 us, respectively. The GI ratio is defined as 1/4 and 1/2. For other symbols (S2-S19), GI is defined as 3.33 us and GI ratio is defined as 1/8 as shown in Figure 3.3.

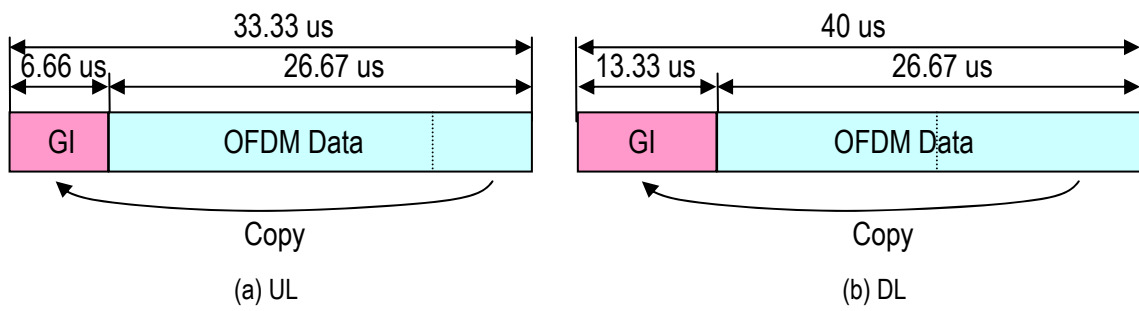

Figure 3.2 Guard Interval (S1)

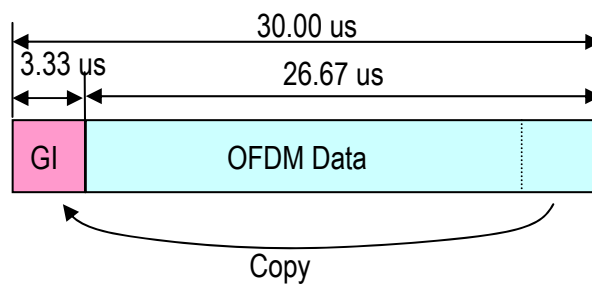

Figure 3.3 Guard Interval (S2-S19)

3.2.2.2 Windowing

Windowing may be used to alleviate discontinuity between symbols as shown in Figure 3.4. The windowing function $w(t)$ depends on the value of the duration parameter. T_{win} is the windowing interval. T_{gi} and T_{data} is guard interval duration and OFDM data duration. Figure 3.4. illustrates smoothed transitions by applying the windowing function shown in Equation 3.1.

$$w(t) = \begin{cases} 0 & , t < -\frac{T_{win}}{2} \\ 0.5 + 0.5 \cos\left\{\frac{\pi}{T_{win}}\left(t + \frac{3T_{win}}{2}\right)\right\} & , -\frac{T_{win}}{2} \leq t < \frac{T_{win}}{2} \\ 1 & , \frac{T_{win}}{2} \leq t < T_{gi} + T_{data} - \frac{T_{win}}{2} \\ 0.5 - 0.5 \cos\left\{\frac{\pi}{T_{win}}\left(t - T_{gi} - T_{data} - \frac{T_{win}}{2}\right)\right\} & , T_{gi} + T_{data} - \frac{T_{win}}{2} \leq t < T_{gi} + T_{data} + \frac{T_{win}}{2} \\ 0 & , T_{gi} + T_{data} + \frac{T_{win}}{2} \leq t \end{cases}$$

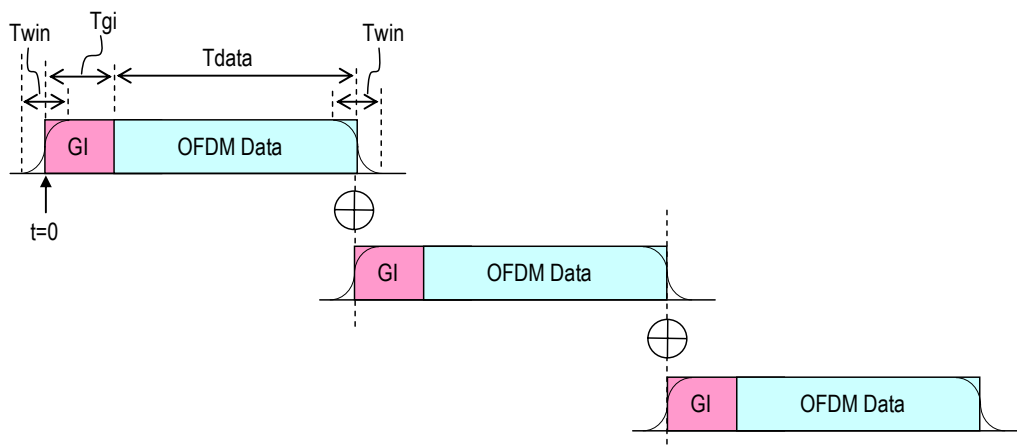

Figure 3.4 Windowing

3.2.3 OFDM Parameters

OFDM parameters for sPHS are shown in Table 3.1.

Table 3.1 OFDM Parameters

Parameter	Type1
System Bandwidth [MHz]	2.4
Effective Channel Bandwidth [MHz]	1.8
Used Subcarrier Number(*1)	48
Subcarrier Spacing [kHz]	37.5
SCH Bandwidth [kHz]	900
Guard Interval Length [us]	6.66 (UL S1), 13.33 (DL S1)
	3.33 (S2-S19)
OFDM Data Length [us]	26.67
OFDM Symbol Length [us]	33.33 (UL S1), 40 (DL S1)
	30 (S2-S19)
Guard Interval Ratio	1/4 (UL S1) 1/2 (DL S1)
	1/8 (S2-S19)
Total Guard Time [us]	51.67 (21.67 + 30; UL), 45 (15 + 30; DL)
OFDM Symbol Number per Subcarrier	19
Windowing	(*2)

(*1) Include DC carrier and Guard carrier

(*2) Refer to Section 3.2.2.2.

Although the length of 3.33 us, 6.66 us, 13.33 us, 26.67 us, 33.33 us, 21.67 us or 51.67 us is used in this document as either of GI length, OFDM data length, OFDM symbol length or guard time for notational convenience, the corresponding length is precisely represented by $10/3$ us, $20/3$ us, $40/3$ us, $80/3$ us, $100/3$ us, $65/3$ us or $155/3$ us, respectively.

3.3 The General Conditions for SC PHY Layer

3.3.1 SC Burst Structure

Figure 3.5 describes a frame structure for SC transmission method. As shown in the figure, one SC burst consists of 19 SC blocks and SC burst length is defined as 573.33 us in one slot. Guard time is the time between the SC burst and subsequent SC burst. Total guard time length is defined as 51.67 us in one slot. For SC transmission method, modulated symbols are mapped into SC blocks.

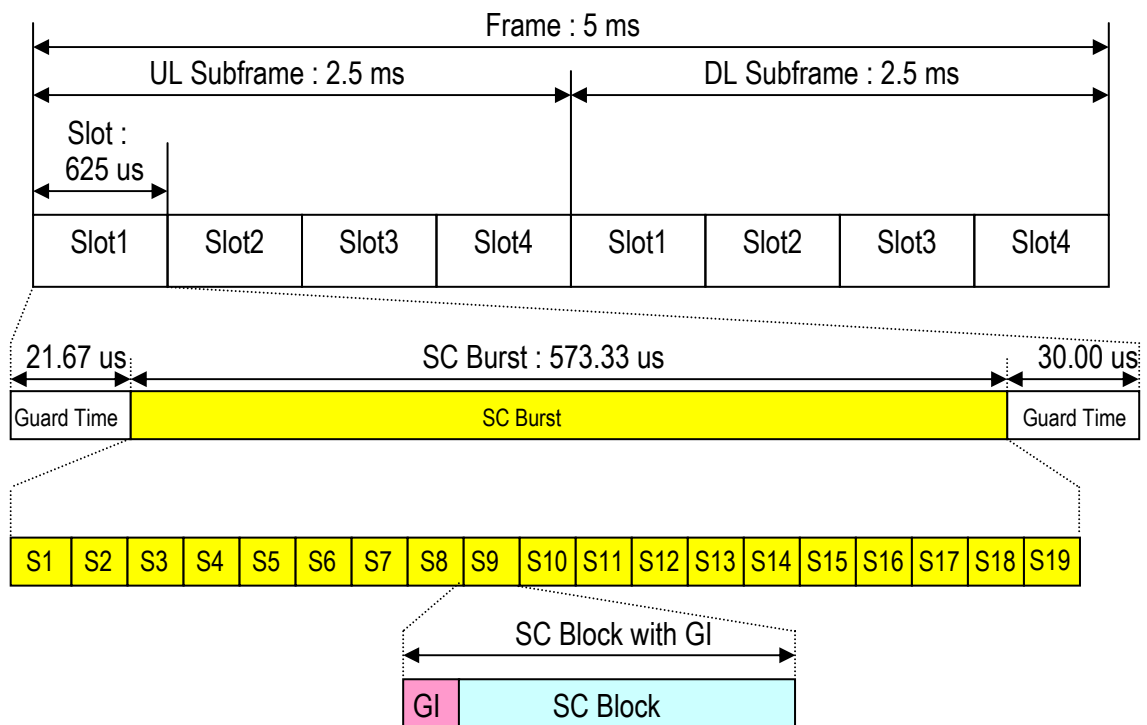

Figure 3.5 Structure of SC Burst for SC Transmission Method

3.3.2 SC Block Structure

SC block is composed of plural symbols. Guard Interval (GI) precedes the SC block as shown in Figure 3.6. SC block length is 26.67 us without GI. GI is described in Section 3.3.2.1. There are two GI lengths for SC block in one SC burst. The length of the first SC block with GI (S1) is defined as 33.33 us. The length of other SC blocks with GI (S2-S19) is defined as 30 us.

3.3.2.1 Guard Interval

GI is defined as a cyclic extension of the SC block in order to avoid the interference caused by delay spread. Guard interval ratio is defined as the ratio of SC block and guard interval length. As shown in Figure 3.6, GI length is defined as 6.66 us and GI ratio is defined as 1/4 for the first SC block (S1). For other SC blocks (S2-S19), GI length is defined as 3.33 us and GI ratio is defined as 1/8 as shown in Figure 3.7.

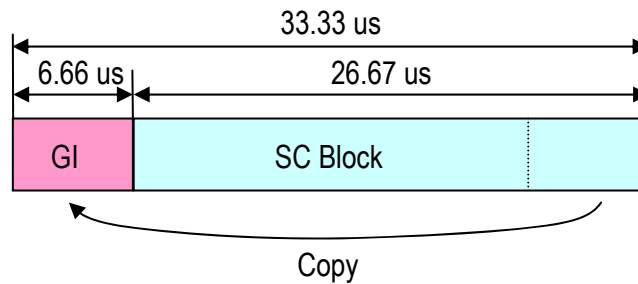

Figure 3.6 SC Block with Guard Interval (S1)

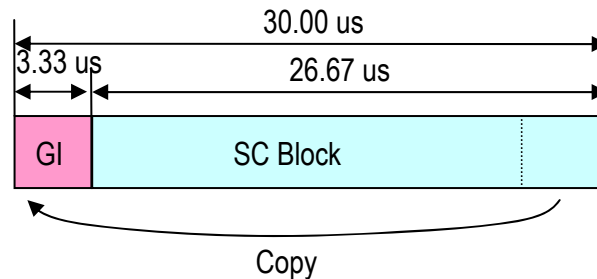

Figure 3.7 SC Block with Guard Interval (S2 – S19)

3.3.2.2 Pulse Shaping Filter

Pulse shaping filter should be applied to a SC burst at the transmitter. Type of pulse shaping filter should be Root Roll-Off Filter (RROF). Roll-off factor of RROF α is 0.45. Equation 3.2 shows the function of RROF pulse shaping filter.

$$P(t) = \frac{2\alpha}{\pi\sqrt{T_s}} \frac{\cos\left\{(1+\alpha)\pi\frac{t}{T_s}\right\} + \frac{T_s}{4\alpha t} \sin\left\{(1-\alpha)\pi\frac{t}{T_s}\right\}}{1 - \left(\frac{4\alpha t}{T_s}\right)^2} \quad (3.2)$$

In this equation, T_s is the reciprocal of the symbol rate.

3.3.3 SC Parameters

SC Parameters for sPHS are shown in Table 3.2. One of two types, Type 1 and Type 2, can be chosen on slot-by-slot basis. In this table, SC block size is defined as the number of symbols in a SC block. GI size is defined as the number of symbols in GI.

Center frequencies for Type 1 and Type 2 are defined by referring to the PRU structure defined in Section 3.4.7. A center frequency is represented as (m, n) indicating the n-th subcarrier (F_n) in the m-th PRU. The PRUs, which are occupied by SC signal, are incrementally numbered from lower frequency to higher frequency, and the initial value for m is 1. The center frequencies are (m,n)=(1,13) for type 1, (2,1) for type 2.

Table 3.2 SC Parameters

Parameter	Type 1	Type 2
Symbol Rate [Msps]	0.6	1.2
Bandwidth [MHz]	0.9	1.8
Number of PRUs	1	2
Number of CRC Units	1	1
SC Block Size [symbol]	16	32
GI Size [symbol]	4 (S1)	8 (S1)
	2 (S2-S19)	4 (S2-S19)
Guard Interval Length [us]	6.66 (S1)	
	3.33 (S2-S19)	
SC Block Length [us]	26.67	
Length of SC Block with GI [us]	33.33 (S1)	
	30 (S2-S19)	
Guard Interval Ratio	1/4 (S1)	
	1/8 (S2-S19)	
Total Guard Time [us]	51.67 (21.67 + 30)	
Pulse Shaping Filter	Root Roll-off Filter	
Roll-off Factor	0.45	0.45

Although the length of 3.33 us, 6.66 us, 26.67 us, 33.33 us, 21.67 us or 51.67 us is used in this document as either of GI length, SC block length, SC block with GI length or guard time for notational convenience, the corresponding length is precisely represented by 10/3 us, 20/3 us, 80/3 us, 100/3 us, 65/3 us or 155/3 us, respectively.

3.4 DL OFDM PHY Layer

Figure 3.8 describes a transmitter block diagram for OFDM transmission method.

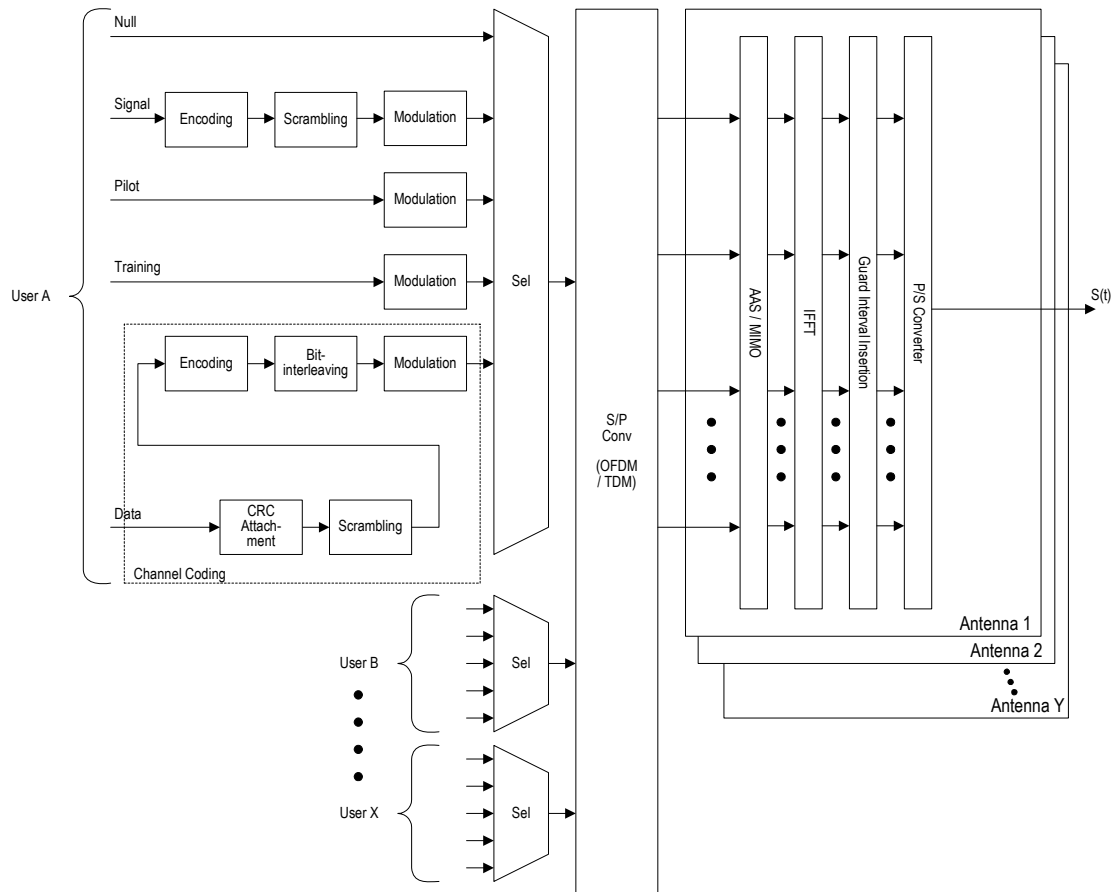

Figure 3.8 Transmitter Block Diagram

3.4.1 Channel Coding for PHY Frame

PHY frame consists of one or more Cyclic Redundancy Check (CRC) data unit(s). CRC-bits are first appended to the CRC data unit. Then tail-bits are appended to the CRC data unit with CRC-bits after performing scrambling. CRC unit is defined as the scrambled CRC data unit with CRC-bits and tail-bits. The size of CRC unit is described in Chapter 4. The CRC unit is encoded according to error-correcting code. Then, bit-interleaving is performed for error-correcting coded bits, and the output bits of bit-interleaving are converted to IQ signals by modulation method. Figure 3.9 describes the channel coding block diagram for DL OFDM of Figure 3.8.

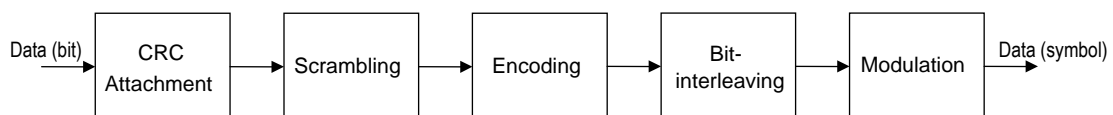

Figure 3.9 Channel Coding

3.4.1.1 CRC

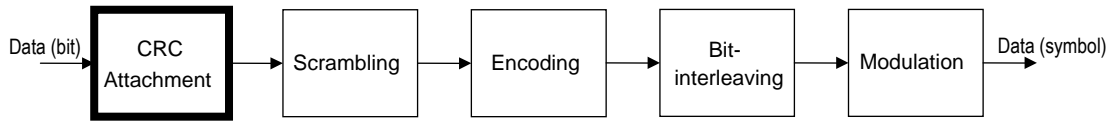

Figure 3.10 CRC Attachment

CRC-bits are appended to each CRC data unit. CRC-bits are generated by either of the following generation polynomials.

$$\text{CRC-16} : 1 + X^5 + X^{12} + X^{16}$$

$$\text{CRC-24} : 1 + X + X^5 + X^6 + X^{23} + X^{24} \text{ (Optional)}$$

Figure 3.11 shows the method of CRC code for CRC-16. The Initial values of shift register SR1-SR16 are set to all 1. Figure 3.12 shows the method of CRC code for CRC-24. The Initial values of shift register SR1-SR24 are set to all 1. The shift register of CRC encoder is initialized for each CRC data unit. In case of Figure 3.11 and Figure 3.12, T1 is switched to the lower side and T2 is closed when CRC-bits are calculated in CRC encoder. After all of data is input into CRC encoder, T1 is switched to the upper side and T2 is opened to output CRC code.

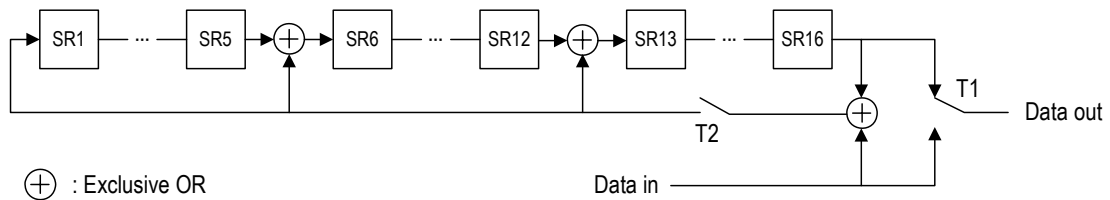

Figure 3.11 The Method of CRC Code for CRC-16

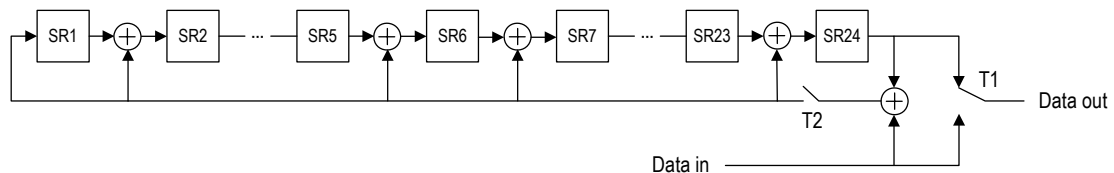

Figure 3.12 The Method of CRC Code for CRC-24

CRC size depends on MAC described in Chapter 4. Application range of CRC is described in Chapter 4.

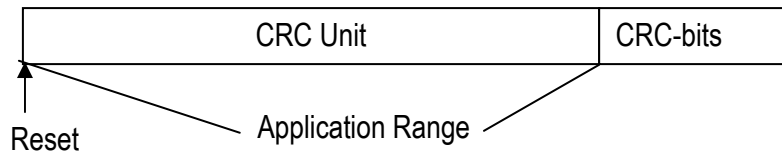

Figure 3.13 CRC Unit with CRC-bits

3.4.1.2 Scrambling

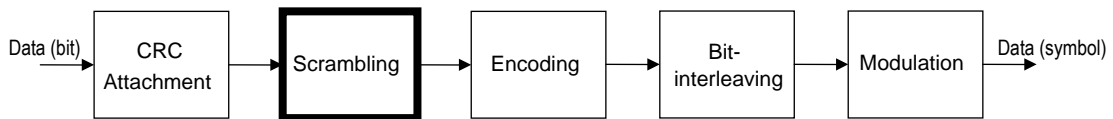

Figure 3.14 Scrambling

The scramble pattern is identical for DL and UL transmission. The generation polynomial is defined as follows:

$$X^{16} + X^{12} + X^3 + X + 1$$

Figure 3.15 shows the structure of scrambling. Initial values of shift register SR16-SR1 are set to the values shown in Table 3.3. The shift register of scrambler is initialized for each CRC data unit.

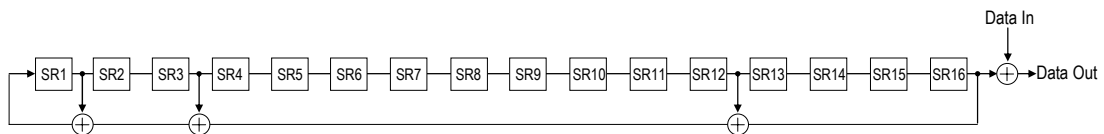

Figure 3.15 Scrambling

Table 3.3 Initial Value of Shift Register SR16-SR1 for Scrambling

Physical Channel	Initial Value of Shift Register SR16-SR1
CCH	All 1
ICH (EXCH only)	1000 0000 0000 0000 xor BSID lower 15 bit xor MSID lower 15 bit
ICH (except for EXCH after confirmation of MSID)	1000 0000 0000 0000 xor BSID lower 15 bit xor MSID lower 15 bit xor (SCH number – 1) (*1)
ICH (except for EXCH before confirmation of MSID)	1000 0000 0000 0000 xor BSID lower 15 bit xor (SCH number – 1) (*1)

(*1) SCH number: Refer to Section 2.4.3.2.

Application range of scrambling is CRC data unit and CRC-bits as shown in Figure 3.16.

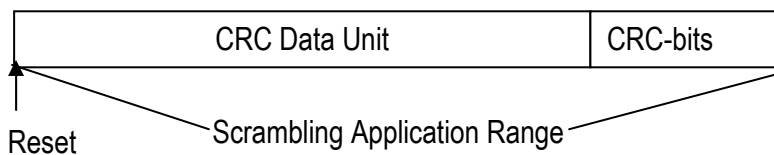

Figure 3.16 Scrambling Application Range

3.4.1.3 Encoding

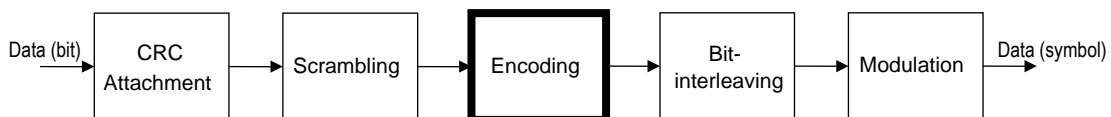

Figure 3.17 Encoding

Error correction code methods are defined as described below.

- (a) Convolutional code (Mandatory)
- (b) Turbo code (Optional)

Table 3.4 summarizes the error correction code for physical channel.

Table 3.4 The Error Correction Code for Physical Channel

Physical channel	Error correction code
CCCH	Convolutional code
ANCH	Convolutional code
EXCH	Convolutional/Turbo code
CSCH	Convolutional code

3.4.1.3.1 Error Correction Encoding

3.4.1.3.1.1 Convolutional Code (Mandatory)

3.4.1.3.1.1.1 Convolutional Encoder

Constraint length of convolutional encoder is 7. Generation polynomials are $G_1=133$ and $G_2=171$ in octal representation. Figure 3.18 illustrates the constitution of convolutional encoder. For this figure, coding rate of convolutional coding becomes 1/2. The initial value of shift register in encoder is 6-bit 0. As an input to the encoder, tail-bits, which consist of 6-bit 0, are appended to the end of scrambled data bits.

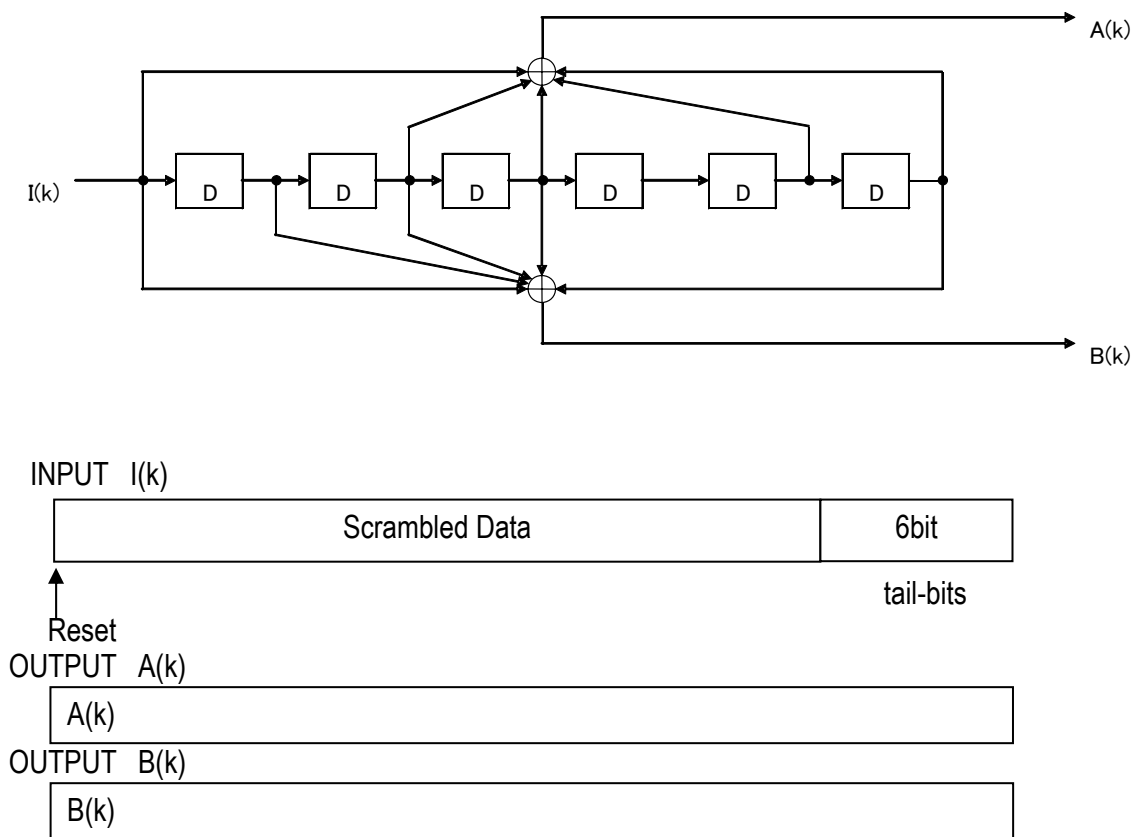

Figure 3.18 Generation Polynomial and Application Range of Convolutional Code

3.4.1.3.1.1.2 Puncturing Pattern

Encoded bits are punctured in order to change coding rate. Table 3.5 describes puncturing pattern related with puncturing rate. In this table, 1 denotes the bits selected and 0 denotes the bits punctured. Figure 3.19 illustrates the puncturing procedure.

Table 3.5 Puncturing Pattern of Convolutional Code

	Puncturing rate R2				
	1	3/4	4/6	6/10	8/14
A	1	11	110	11010	1111010
B	1	10	101	10101	1000101

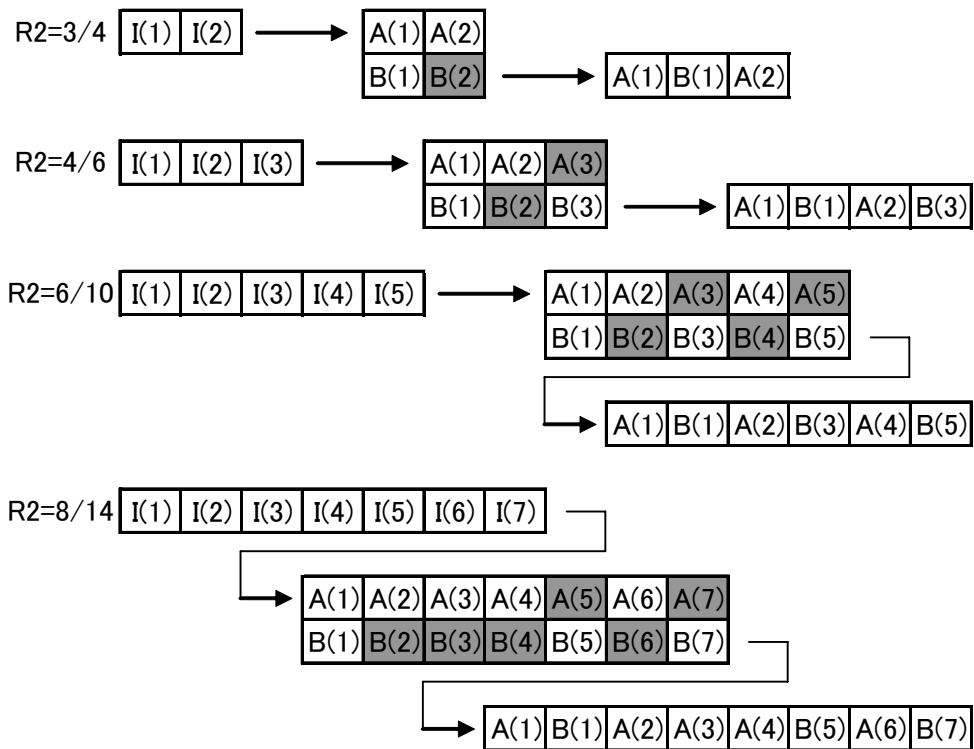

Figure 3.19 Puncturing Procedure for Convolutional Code

3.4.1.3.1.2 Turbo Code (Optional)

3.4.1.3.1.2.1 Turbo Encoder

Turbo encoder consists of two recursive systematic convolutional encoders connected in parallel, with an interleaver, which is called turbo interleaver, preceding the second constituent encoder. Output bits from turbo encoder consist of systematic bits $I(k)$ and parity bits $A(k)$ and $B(k)$ from each constituent encoder. The two constituent encoders have the same structure as follows. Generation polynomials of each constituent encoder are $G_1 = 15$ and $G_2 = 13$, which denote feedforward and feedback polynomial in octal representation respectively. Figure 3.20 illustrates the constitution of turbo encoder. For this figure, coding rate of turbo coding becomes $1/3$.

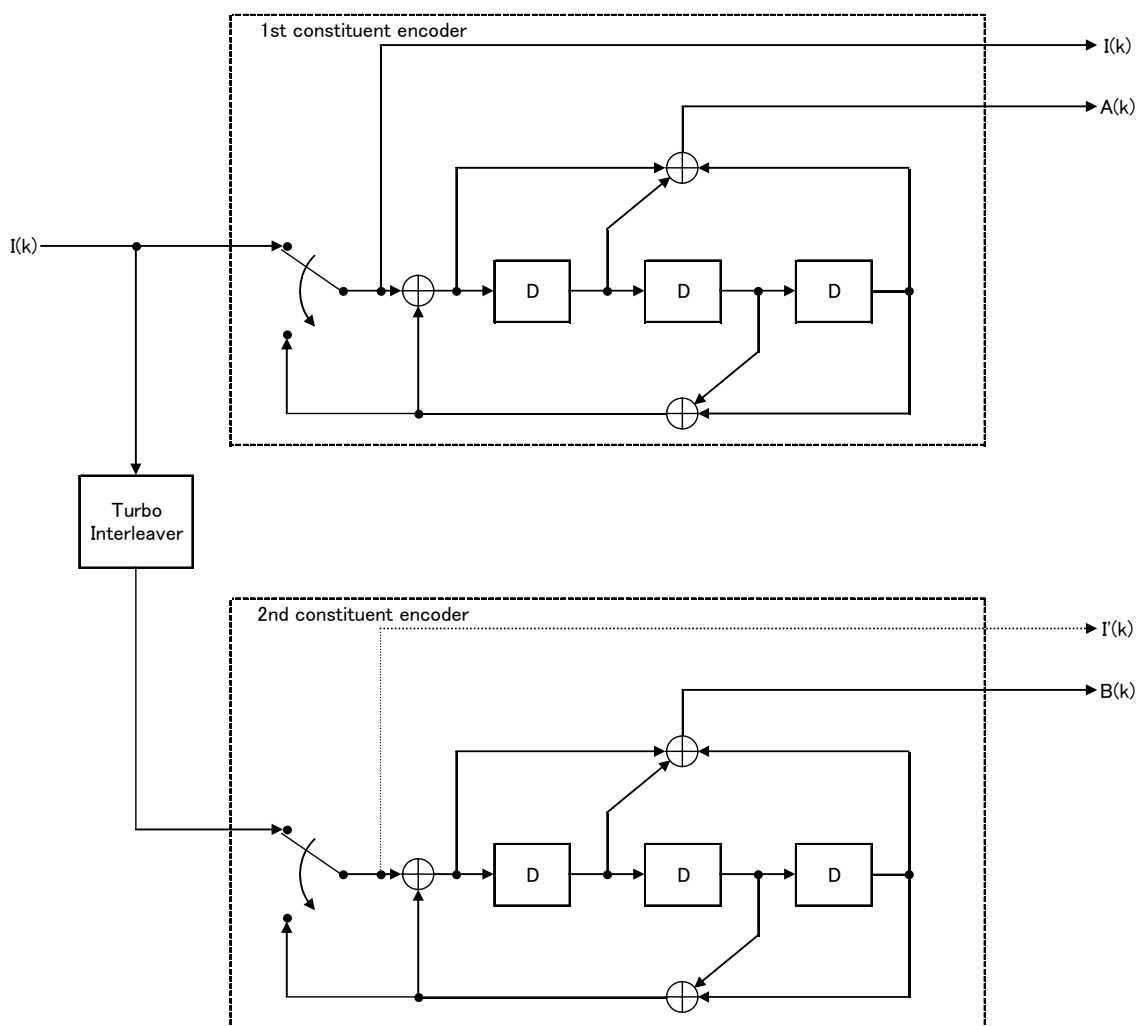

Figure 3.20 Structure of Turbo Encoder

3.4.1.3.1.2.2 Turbo Code Termination

After all information bits are encoded, trellis termination is performed by padding 6 tail-bits. First, by setting switches to the down position, each encoder outputs 3 systematic bits and 3 parity bits. If the number of information bits is N , outputs of 1st and 2nd constituent encoders are as follows:

$I(N+1), A(N+1), I(N+2), A(N+2), I(N+3), A(N+3)$ from 1st constituent encoder
 $I'(N+1), B(N+1), I'(N+2), B(N+2), I'(N+3), B(N+3)$ from 2nd constituent encoder

Next, to generate rate-1/3 encoder outputs corresponding to the 6 tail-bits, every systematic bit is repeated and 18 encoded bits are generated as follows:

$I(N+1), I(N+1), A(N+1), I(N+2), I(N+2), A(N+2), I(N+3), I(N+3), A(N+3),$
 $I'(N+1), I'(N+1), B(N+1), I'(N+2), I'(N+2), B(N+2), I'(N+3), I'(N+3), B(N+3)$

After performing this repetition process, these tail-corresponding bits are rearranged and added after $I(N), A(N)$ and $B(N)$ as follows:

$I(N+1), I(N+2), I(N+3), I'(N+1), I'(N+2)$ and $I'(N+3)$ are added after $I(N)$,
 $I(N+1), I(N+2), I(N+3), I'(N+1), I'(N+2)$ and $I'(N+3)$ are added after $A(N)$,
 $A(N+1), A(N+2), A(N+3), B(N+1), B(N+2)$ and $B(N+3)$ are added after $B(N)$.

3.4.1.3.1.2.3 Turbo Interleaver

Turbo interleaver interleaves with input information bits, and transmits the interleaved bits to the second constituent encoder. Turbo interleaving is equivalent to a process, in which the entire sequence of input information bits are written sequentially into an array, and then read out by the given procedure. The input bits to the turbo interleaver are denoted by $I(1), I(2), \dots, I(d)$, where d is the length of input bits. The procedure of interleaving is described as follows:

1. Determine the turbo interleaver parameter M and N as shown in Table 3.6.

Table 3.6 Turbo Interleaver Parameter M and N

Payload size	M	N
372	20	19
744	28	27
1116	34	33
1488	41	37
2232	48	47
2976	57	53
4464	69	65
5952	78	77
6696	83	81
8928	95	94

2. Write the input information bits into the M rows N columns matrix row by row starting with bit $a_{1,1}$ in column 1 of row 1 as shown in Figure 3.21.

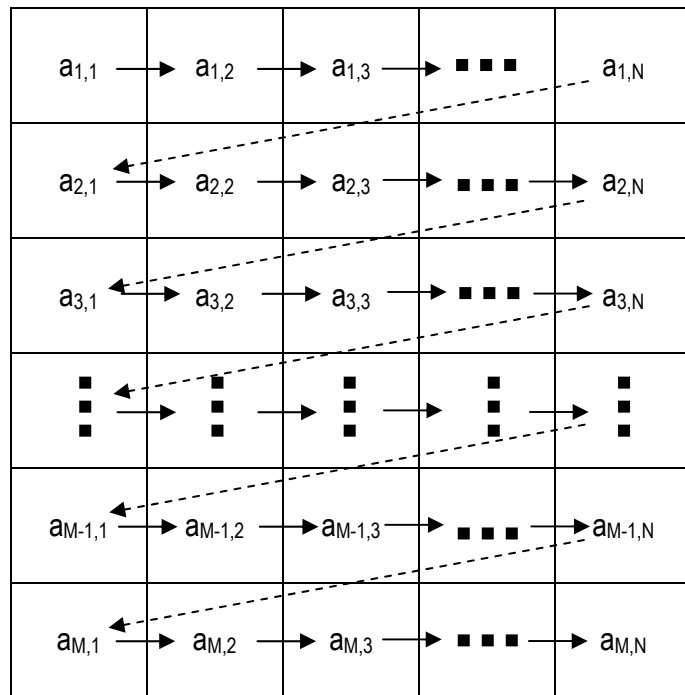

Figure 3.21 Turbo Interleaver Matrix (Write-in)

If $MN > d$, dummy bits are padded in $a_{M,N-MN+d+1}$ through $a_{M,N}$. These dummy bits are pruned away from read-out sequence.

3. Read out the interleaved bits as follows. First, set $i=M$ and $j=1$. After reading out the bit $a_{i,j}$, i is decremented by 1 and j is incremented by 1. If $i=0$, then i is set to M . If $j=N+1$, then j is set to 1. These process is repeated until $M*N$ bits are read out. The order of reading out is described in Figure 3.22.

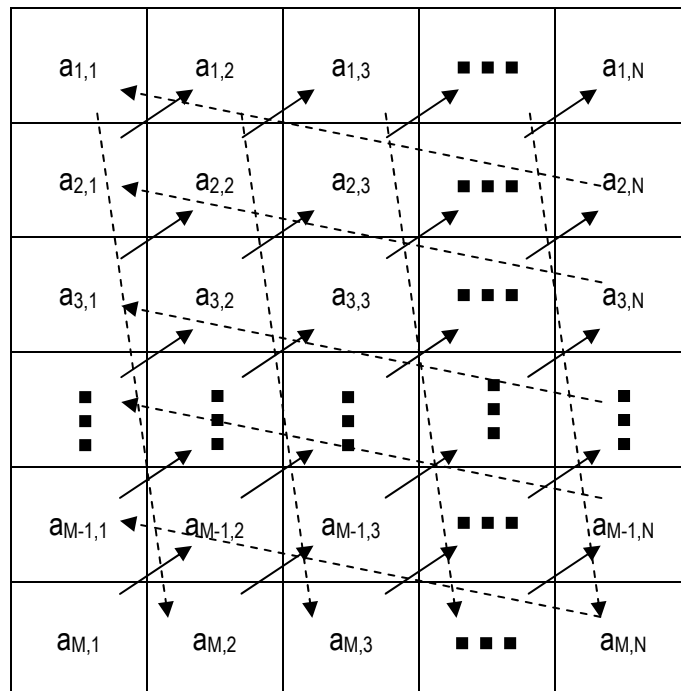

Figure 3.22 Turbo Interleaver Matrix (Read-out)

4. Remove the dummy bits padded in 2.

The number of the read-out bits is $M \cdot N$ after reading out all the written bits, and the number of dummy bits is $M \cdot N - d$ after deleting the padded dummy bits. Hence, the total number of output bits becomes d .

3.4.1.3.1.2.4 Puncturing pattern

Punctured turbo encoded bits consist of systematic bits and punctured parity bits. Assume that coding rate R_2 is $k/(k+1)$, while k is 1, 2, 3, 5 and 7 parity bits are selected in every $2 \cdot k$ parity bits at each constituent encoder, except for the case of k being 7. In case of k being 7, puncturing pattern has to be specified so that all trellis state will be appeared because period of feedback polynomial at each constituent encoder is 7. Table 3.7 describes puncturing patterns at each coding rate. $P(m_1, m_2, \dots, n_1, n_2, \dots)$ represents that (m_1, m_2, \dots) -th parity bits are selected in every $2 \cdot k$ parity bits at the first constituent encoder and (n_1, n_2, \dots) -th parity bits are selected in every $2 \cdot k$ parity bits at the second constituent encoder, while k is 1, 2, 3 and 5. While k is 7, (m_1, m_2, \dots) -th parity bits are selected in every 98 parity bits at the first constituent encoder and (n_1, n_2, \dots) -th parity bits are selected in every 98 parity bits at the second constituent encoder. Figure 3.23 illustrates the punctured turbo procedure with encoded bits while R_2 is 1/2, 2/3, 3/4 and 5/6. Figure 3.24 illustrates the punctured turbo coding procedure while R_2 is 7/8. As shown in Figure 3.24, a parity bit is selected from every 15 bits in 98 parity bits at each constituent encoder.

Table 3.7 Coding Rate and Puncturing Pattern

Coding Rate	Puncturing Pattern
1/2	P(1,2)
2/3	P(1,3)
3/4	P(1,4)
5/6	P(1,6)
7/8	P(1 16 31 46 61 76 91,8 23 38 53 68 83 98)

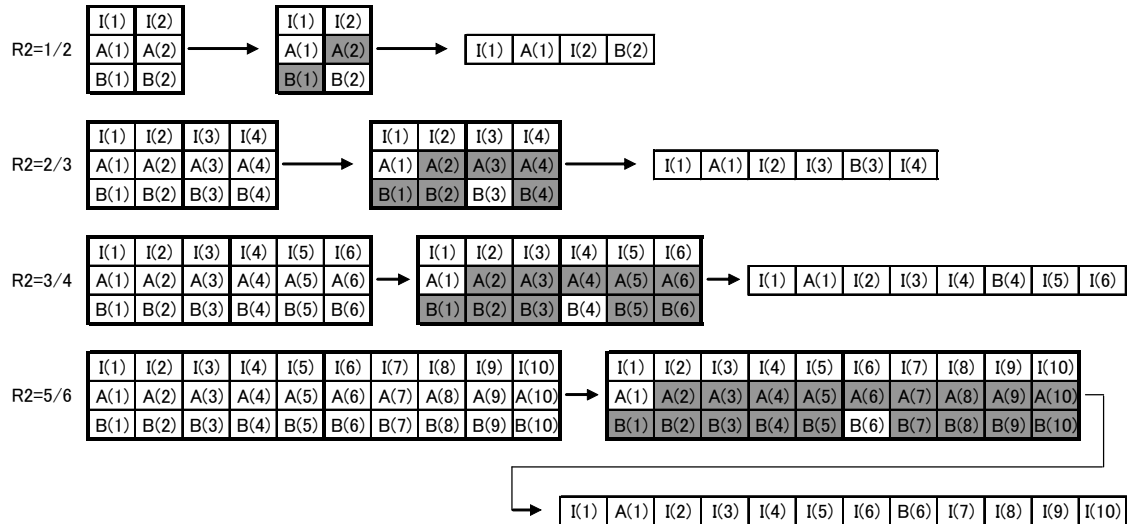

Figure 3.23 Puncturing Procedure while R2 is 1/2, 2/3, 3/4 and 5/6

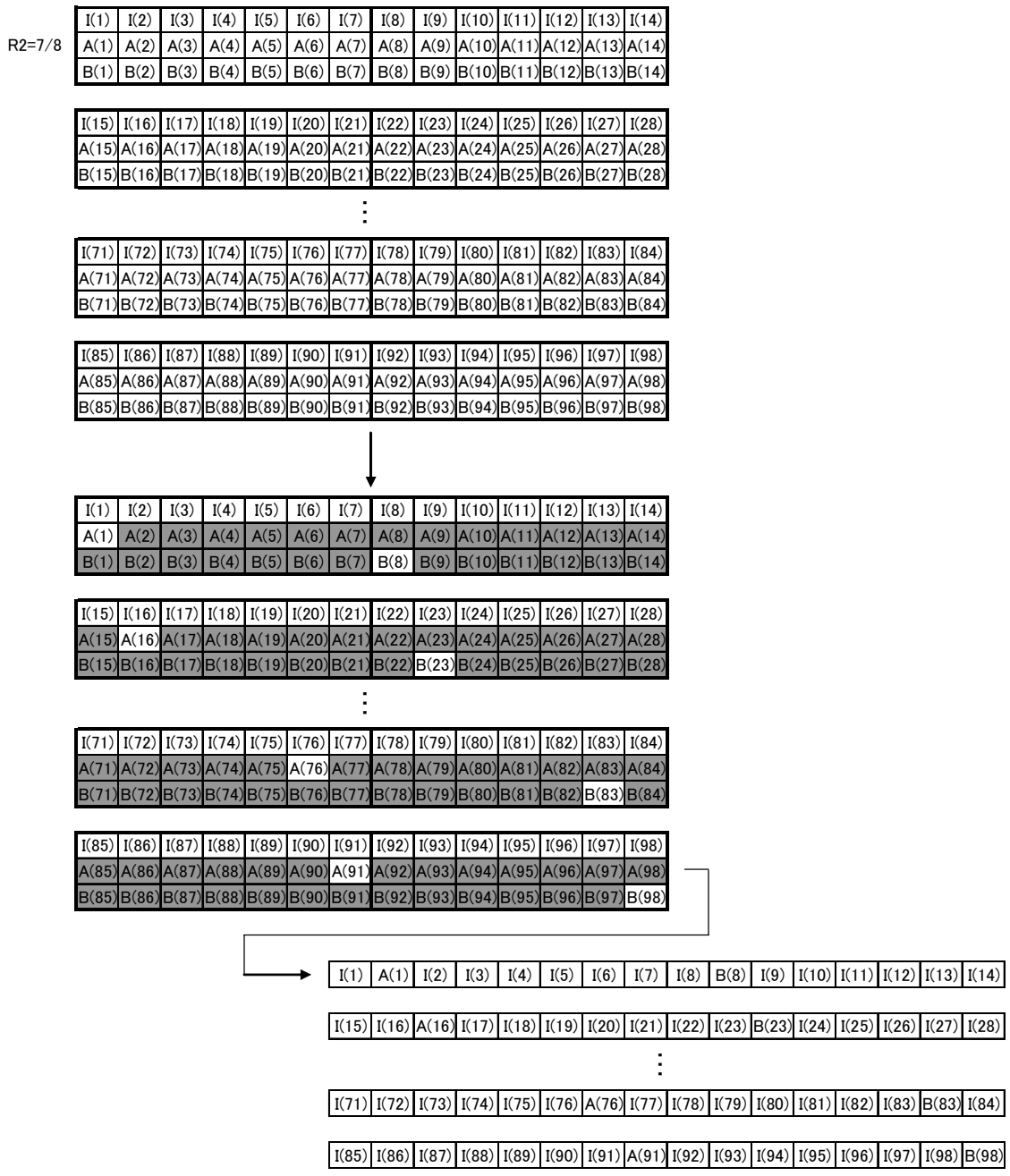

Figure 3.24 Puncturing Procedure while R2 is 7/8

3.4.1.4 Bit-interleaving

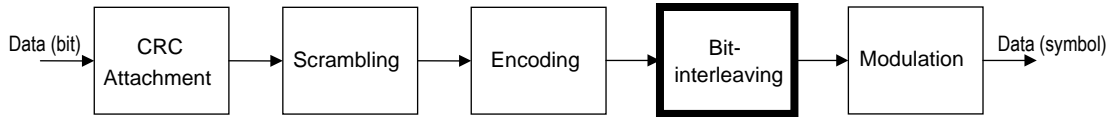

Figure 3.25 Interleaving

3.4.1.4.1 Bit-interleaver Structure

Figure 3.26 illustrates the application range of bit-interleaving. In this figure, the parameter $b(1), \dots, b(xy)$ is the bit series after encoding. The number of input bits to the interleaver is $x \cdot y$, where the parameter x is the number of bits in a symbol and the parameter y is the number of symbols(*1). The bit-interleaver unit consists of x block interleavers. Each block interleaver interleaves y bits separately. The details on the block interleaver are described in Section 3.4.1.4.2.

(*1) In case of BPSK or $\pi/2$ -BPSK with coding rate of $2/3$ for CSCH, one dummy bit of 0 is appended to the end of the punctured bits. In other cases, the punctured bits equal to the input bits of bit-interleaver.

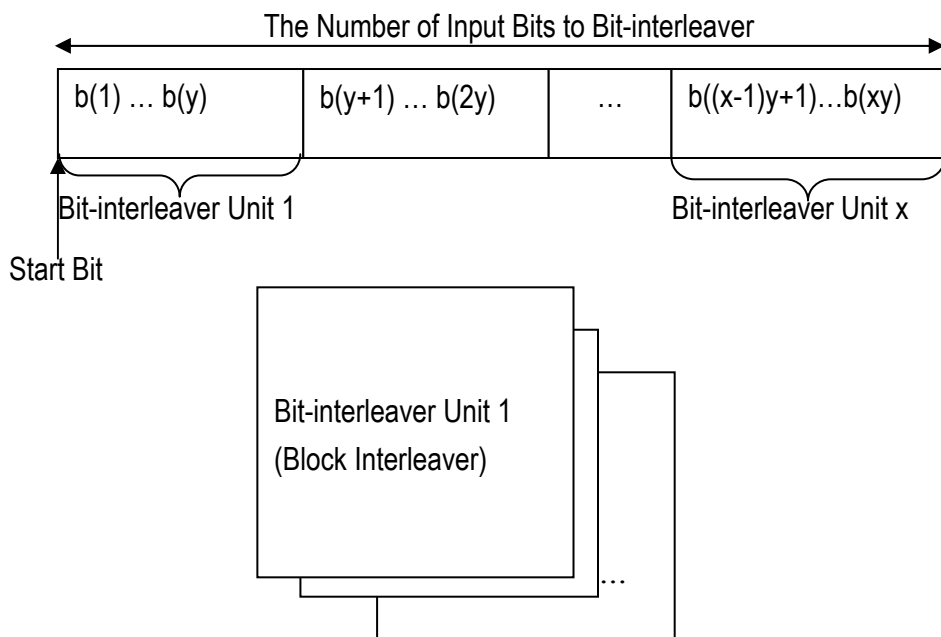

Figure 3.26 Application Range of Bit-interleaving

3.4.1.4.2 Block Interleaver Method

Block interleaver is used for each y bits in each column as explained in Figure 3.26. Input bits are written sequentially into an array per bit in symbol, and then read out by the given procedure. The number of input bits to the interleaver depends on symbol size of physical channel and modulation class. The procedure of interleaving is described as follows:

1. Determine the interleaver parameter x and y based on the number of input bits and modulation class.
2. Determine the block interleaver parameter N and M for each physical channel, where $y = N * M$, N is column size, and M is row size.
3. Write the input information bits into the M -row N -column matrix row. Write starting position shall be set according to bit position i ($i=1, \dots, x$) in a symbol. Figure 3.27 illustrates block interleaver matrix for writing in case of n being 1.
4. Read the written bits from the M -row N -column matrix row to interleave each bit in symbol and each symbol. Read starting position shall be set according to bit position in a symbol. Figure 3.28 illustrates a block interleaver matrix for reading in case n being 1.

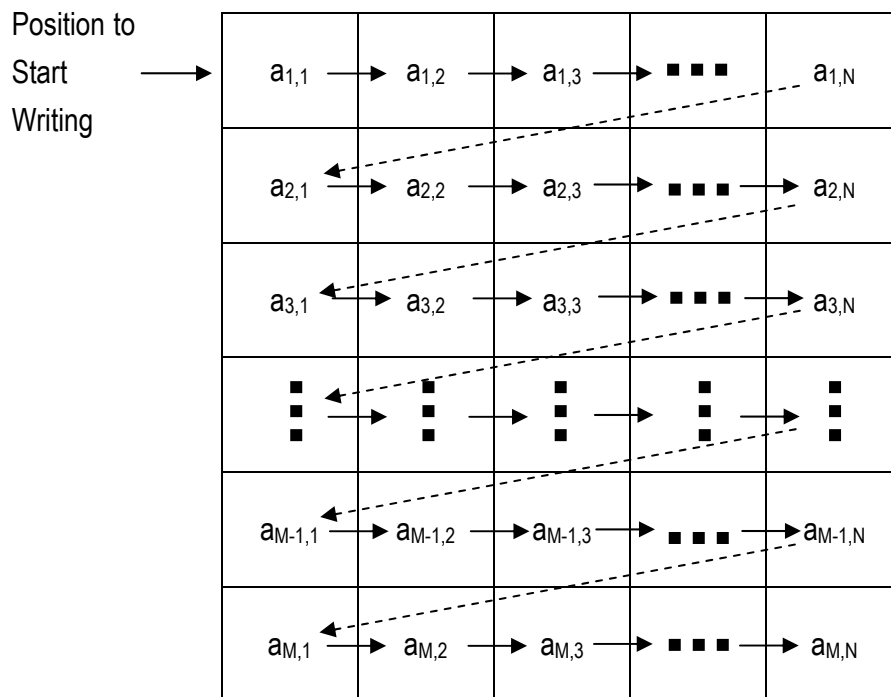

Figure 3.27 Interleaver Matrix (Write-in) in case of n being 1

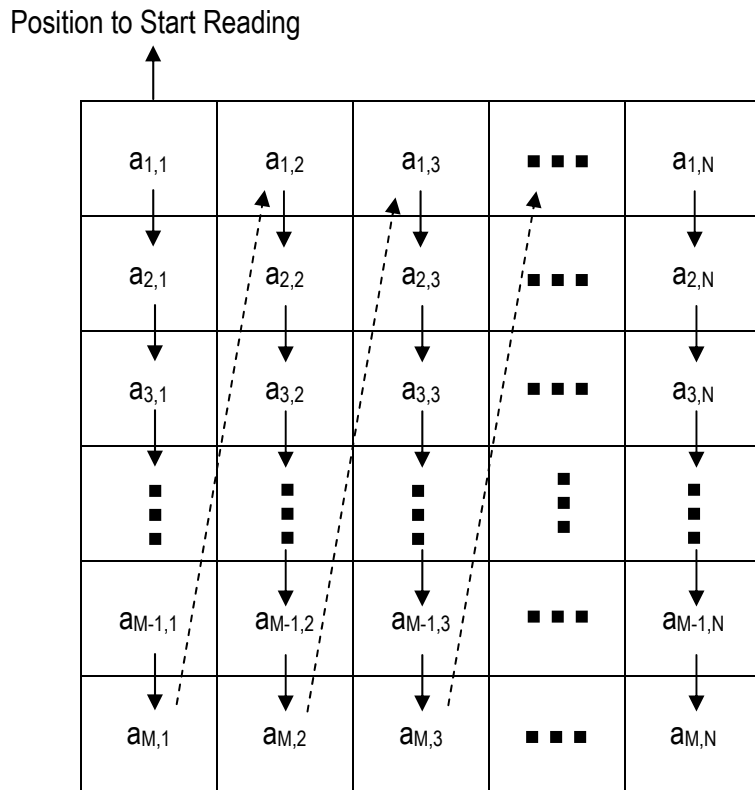

Figure 3.28 Interleaver Matrix (Read-out) in case of n being 1

3.4.1.4.3 Interleaver Parameters for OFDM

Table 3.8 and Table 3.9 summarize the parameters of the interleaver for input bit size and modulation class.

Table 3.8 Interleaver Parameter M and N

Number of Symbols y	M	N
324	27	12
364	28	13
372	31	12
390	30	13
408	34	12
744	62	12
780	60	13
798	57	14
816	68	12

Table 3.9 Interleaver Parameter

Modulation	The Number of Block Interleavers
BPSK	1
QPSK	2
16QAM	4
64QAM	6
256QAM	8

Table 3.10 summarizes the definition of bit position i ($i=1,\dots,x$) in a symbol.

Table 3.10 The Definition of Bit Position i in a Symbol

Modulation	Bit Position i in a Symbol
BPSK	$i = (1)$
QPSK	$i = (1,2)$
16QAM	$i = (1,2,3,4)$
64QAM	$i = (1,2,3,4,5,6)$
256QAM	$i = (1,2,3,4,5,6,7,8)$

Table 3.11 summarizes the position to start writing and the position to start reading for interleaver.

Table 3.11 Starting Position for Interleaver

Bit position i in a Symbol	Position to Start Writing	Position to Start Reading
1	$a_{1,1}$	$a_{1,1}$
2	$a_{3,1}$	$a_{1,2}$
3	$a_{5,1}$	$a_{1,3}$
4	$a_{7,1}$	$a_{1,4}$
5	$a_{9,1}$	$a_{1,5}$
6	$a_{11,1}$	$a_{1,6}$
7	$a_{13,1}$	$a_{1,7}$
8	$a_{15,1}$	$a_{1,8}$

If this interleaver is represented by equation, the permutation of the i -th block interleaver is defined as following.

$$lout = \{[N*(j-1) \bmod M*N + (\text{floor}((j-1)/M)+(c-1)) \bmod N + N*(M-(r-1))] \bmod M*N\} + (i-1)*M*N+1$$

$$y = M*N$$

$$j = 1,\dots,y$$

$$i = 1,\dots,x$$

$$lin = 1,\dots,xy$$

The function floor() denotes the largest integer not exceeding the parameter.

lout : the permutation after interleaver

r : Write starting position $a_{r,1}$ in bit position of a symbol

c : Read starting position $a_{1,c}$ in bit position of a symbol

y : the number of symbol

x : the number in a symbol

M : row of block interleaver

N : column of block interleaver

lin : the permutation before interleaver : $j + (i-1)*y$

For the parameter r and c, refer to Table 3.11 and Table 3.25.

The procedure of interleaving is performed as following:

1. Set $j = 1$ and $i = 1$. Then increase j to y .
2. Set $j = 1$ and $i = i + 1$. Then increase j to y .
3. Repeat 2 until i equals to x .

3.4.1.4.4 Output-bits after Bit-interleaver

The IQ data symbol is generated by using x bits, each of which is taken from each block interleaver. Denote the output bits from i -th block interleaver by $z(i,1), z(i,2), \dots, z(i,y)$. Thus, the j -th IQ data symbol is converted from the bit series $z(p_1,j), z(p_2,j), \dots, z(p_x,j)$, where p_i is an offset value to circulate the order of input bits to the modulator. The process is defined as follows:

Input bits to the modulator: $z(p_1,j), z(p_2,j), \dots, z(p_x,j)$

Offset value: $p_i = ((i+j-2) \bmod x) + 1$

3.4.1.5 Modulation Method

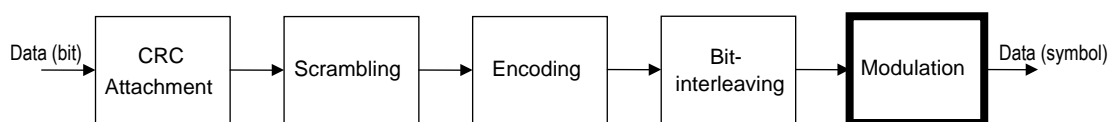

Figure 3.29 Modulation

The serial signal input after interleaving is converted to IQ Data symbol on each symbol. The constellation mapping for each modulation (BPSK, QPSK, 16QAM, 64QAM and 256QAM) is shown in Appendix B.

- a) BPSK
Refer to Appendix B.1.
- b) QPSK
Refer to Appendix B.3.
- c) 16QAM
Refer to Appendix B.6.
- d) 64QAM
Refer to Appendix B.7.
- e) 256QAM
Refer to Appendix B.8.

3.4.1.6 Symbol Mapping Method to PRU

Symbol mapping methods depend on the types of physical channel (CCCH, ANCH, EXCH and CSCH). The detail of the mapping method is described below.

3.4.1.6.1 Symbol Mapping Method for CCCH, ANCH and CSCH

As shown in Figure 3.30, the data symbol mapping is performed by aligning the data symbols along frequency axis, and then aligning them along time axis per PRU.

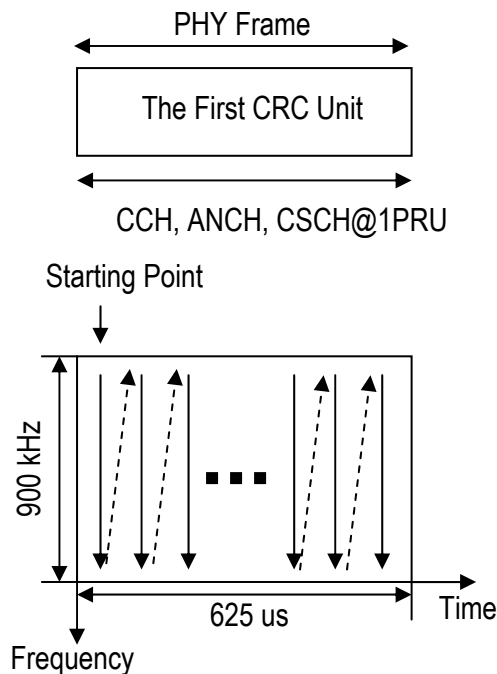

Figure 3.30 Data Symbol Mapping Method for CCCH, ANCH and CSCH

3.4.1.6.2 Symbol Mapping Method for EXCH

3.4.1.6.2.1 Symbol Mapping without DTX Symbol

As shown in Figure 3.31, the data symbol mapping is performed by aligning the data symbols along frequency axis, and then along time axis. The data symbols of the first CRC unit are inserted firstly, and the symbols of the second CRC unit are inserted next.

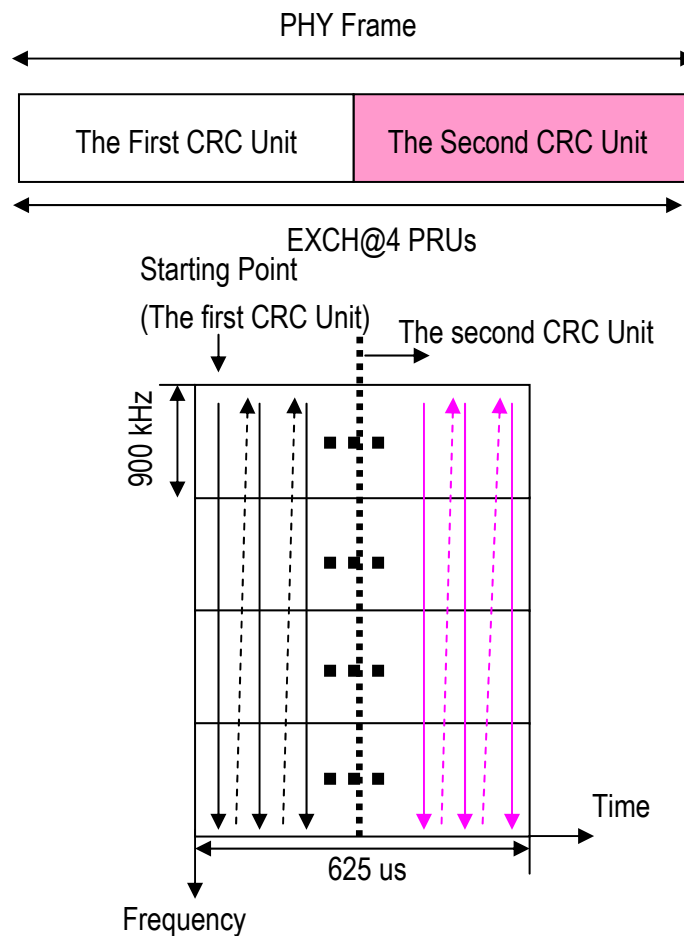

Figure 3.31 Data Symbol Mapping Method for EXCH (In Case of PRU being 4)

3.4.1.6.2.2 Symbol Mapping with DTX Symbol

DTX symbol is used in case of EXCH. As shown in Figure 3.32, when PHY frame is fewer than PRU total size, all data symbols are inserted, and then DTX symbol is inserted to the last. The definition of DTX is described in Section 3.4.5.

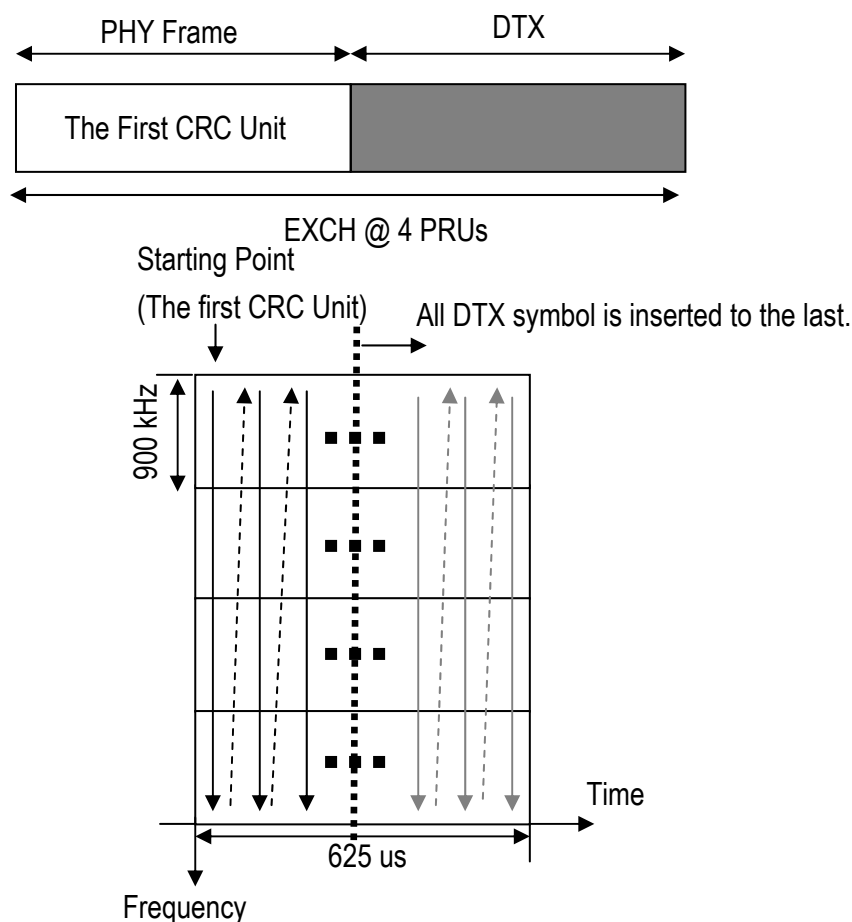

Figure 3.32 DTX Symbol Mapping Method for EXCH (In Case of PRU being 4)

3.4.1.6.3 Symbol Mapping Method for Retransmission of CC-HARQ

In case of EXCH retransmission, the retransmission CRC unit size is not necessarily the same as the PRU size in case of PRU connection. (a) explains the case that the retransmission CRC unit size equals to the retransmission PRU size. (b) explains the case that the retransmission CRC unit size is smaller than the retransmission PRU size. (c) explains the case that the retransmission CRC unit size is larger than the retransmission PRU size.

(a) The case when Retransmission CRC Unit Size equals to Retransmission PRU Size

Figure 3.33 and Figure 3.34 illustrate the case that retransmission CRC unit size equals to the retransmission PRU size. Figure 3.33 shows the case that retransmission data 2 and PRU size 2 equal to retransmission data 1 and PRU size 1. Figure 3.34 shows the case that retransmission data1 and PRU size 1 differ from retransmission data 2 and PRU size 2, when full subcarrier mode is used.

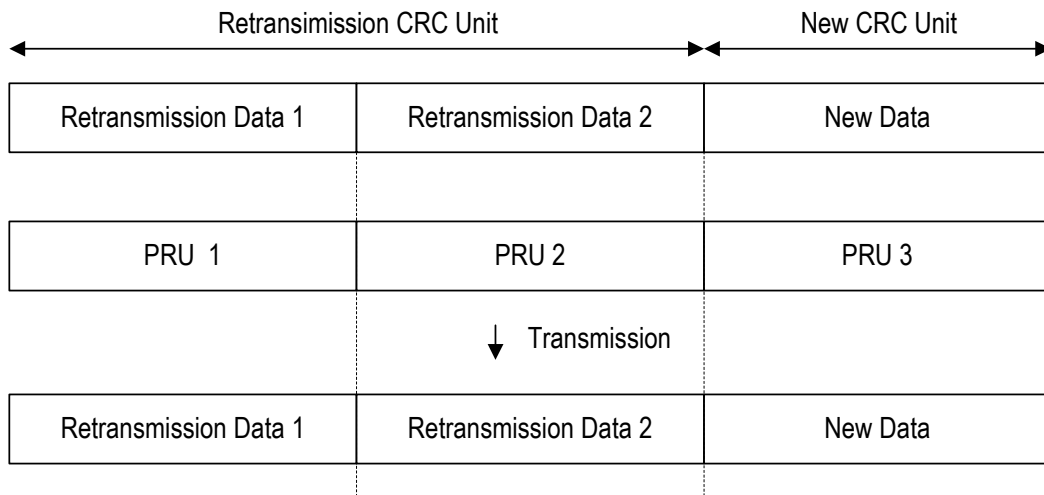

Figure 3.33 The case when Retransmission CRC Unit Size equals to Retransmission PRU Size (1)

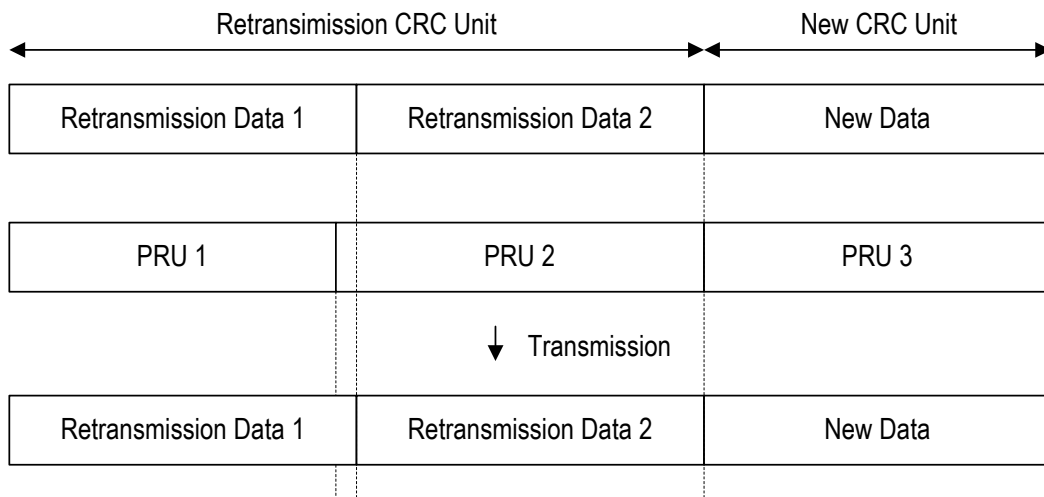

Figure 3.34 The case when Retransmission CRC Unit Size equals to Retransmission PRU Size (2)

(b) The case when Retransmission CRC Unit Size is smaller than Retransmission PRU Size
 Figure 3.35 illustrates the case that retransmission CRC unit size is smaller than retransmission PRU size. As shown in this figure, the rest of PRU 4 is used as DTX symbols.

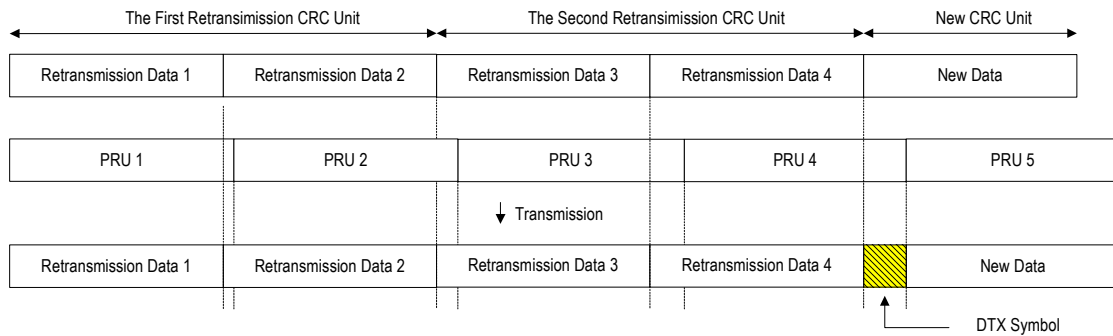

Figure 3.35 The case when Retransmission CRC Unit Size is smaller than Retransmission PRU Size

(c) The case when Retransmission CRC Unit Size is larger than Retransmission PRU Size
 Figure 3.36 illustrates the case that retransmission CRC unit size is larger than retransmission PRU size. As shown in the figure, a part of retransmission data 4 takes up the symbols that can be used by DTX symbols. In addition, a part of retransmission data 4 might also take up a part of the guard time.

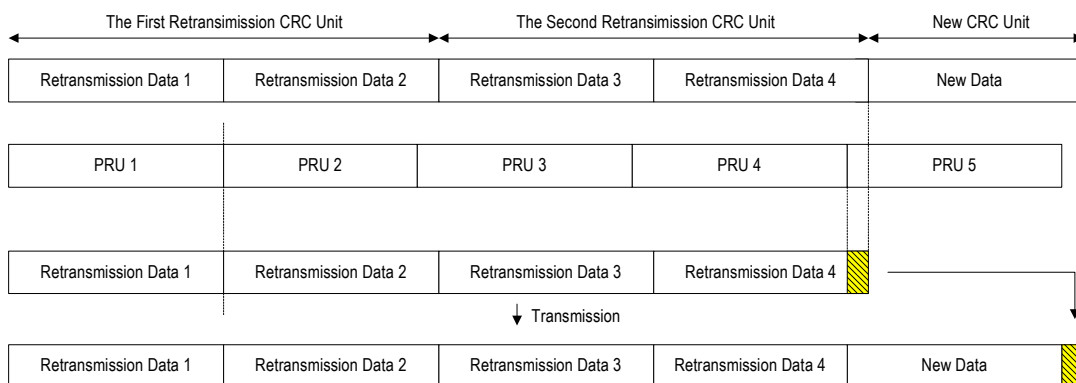

Figure 3.36 The case when Retransmission CRC Unit Size is larger than Retransmission PRU Size

3.4.1.7 Summary of OFDM DL Channel Coding

Combinations of coding and modulation are shown in Table 3.12. Also, the efficiency of each combination is shown in the same table.

The OFDM DL channel coding for sPHS is summarized in Table 3.12.

Table 3.12 Summary of OFDM DL Channel Coding

Modulation	Scaling Factor	Coding rate R1 @convolutional coding	Puncturing rate R2	Coding rate R @total	Efficiency
BPSK	1	1 / 2	1	1 / 2	0.5
			3 / 4	2 / 3	0.67
QPSK	1/√2		1	1 / 2	1
			4 / 6	3 / 4	1.5
16QAM	1/√10		1	1 / 2	2
			4 / 6	3 / 4	3
64QAM	1/√42		3 / 4	4 / 6	4
			6 / 10	5 / 6	5
256QAM	1/√170		4 / 6	6 / 8	6
			8 / 14	7 / 8	7

3.4.2 Training Format for DL OFDM

Training format is used mainly for synchronization, frequency offset estimation, automatic gain control or weight calculation of beam-forming. Training format is composed of pre-defined data (Refer to Appendix C.1). The details of training format, training sequence, and training pattern are described in Sections 3.4.2.1, 3.4.2.2 and 3.4.2.3.

3.4.2.1 Training Format

Training format is used for ICH and CCCH as described in Sections 3.4.2.1.1 and 3.4.2.1.2. Training format for ICH and the format for CCCH are chosen according to the training index as defined in Section 3.4.2.3.

3.4.2.1.1 Training Format for ICH

ICH is composed of ANCH, EXCH and CSCH. As shown in Figure 3.37, 1/4 or 1/2 of the original training data is copied ahead of the data. This training format is used for ICH. As described in Sections 3.4.7.2 and 3.5.7.2, training symbol S1 is used for ICH.

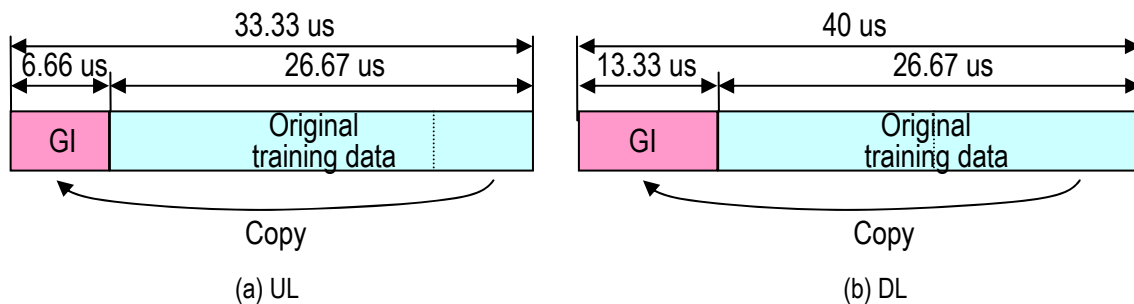

Figure 3.37 Training Format for Single Symbol (S1)

3.4.2.1.2 Training Format for CCCH

As shown in Figure 3.38, 3/8 or 5/8 of the original training data (the second OFDM data) is copied ahead of the first OFDM data. The phase of this format must be consecutive. As described in Sections 3.4.7.1.1 and 3.5.7.1.1, training symbols S1 and S2 are used for CCCH.

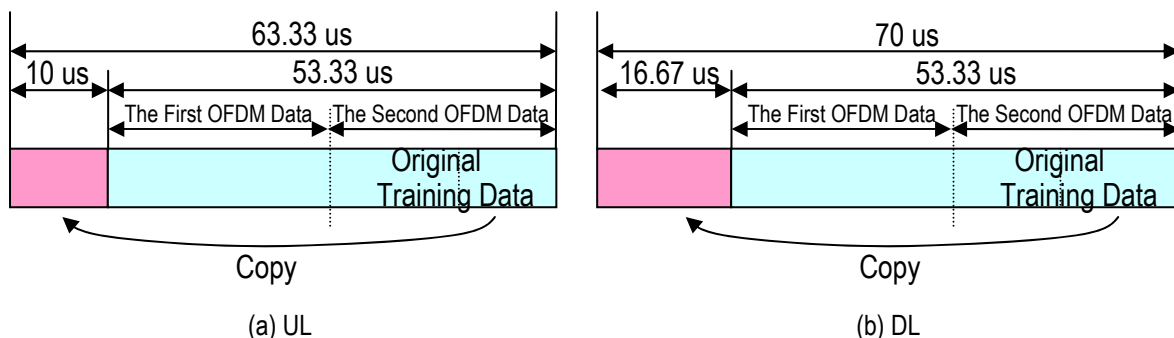

Figure 3.38 Training Format for Two Symbols

3.4.2.2 Training Sequence

The training sequence of each SCH is decided by the training core-sequence number and the offset value number that is described in Sections 3.4.2.3.1 and 3.4.2.3.2. The calculated core-sequence is chosen from 12 core-sequences defined in Table C.1 to Table C.3 in Appendix C. The calculated offset value number chooses the offset sample as shown in Table C.4. The offset sample shifts the core-sequence cyclically. To generate the training sequence of each SCH, the core-sequence and the offset sample are substituted in Equation C.1. The example of generation is shown in Table C.5. When offset value number is 1, the training sequence becomes the same as the core-sequence. Offset value depends on the number of SCHs. Training symbol shall be boosted by 2.5 dB ($=4/3$) compared with data symbol.

3.4.2.3 Training Index

As described in Section 3.4.2.2, there are 12 core-sequences and offset values (cyclic-shift values). Training index is numbered as follows:

Training Index = Core-sequence Number + (Offset Value Number-1)*12

n = maximum number of SCH in a slot,

3.4.2.3.1 Training Index for CCCH

Training index, core-sequence number and offset value number for CCCH are defined as follows:

Training Index : 2 for UL, 1 for DL

Core-sequence Number : 2 for UL, 1 for DL

Offset Value Number : 1

3.4.2.3.2 Training Index for ICH

Training index, core-sequence number and offset value number for ICH are defined as follows:

Training Index : $(x + (y-1)*12)$

Core-sequence Number : $x=[A \text{ MOD } 12] + 1$

Offset Value Number : $y(m)=[\{B + m\} \text{ MOD } (n-1)] + 2$

n = maximum number of SCHs in a slot

m = SCH number : 2,...,n

A = 1st to 5th bits including LSB in BSID

B = 1st to 5th bits next to A in BSID

Training index, core sequence number and offset value number for MIMO are defined as follows:

Training index : $x + (y-1)*12$

Core-sequence number : $x(k)=[\{A + k - 1\} \text{ MOD } 12] + 1$

Offset value number : $y(m)=[\{B + m\} \text{ MOD } (n-1)] + 2$

k =MIMO stream number (k=1,2,...)

n = maximum number of SCH in a slot

m = SCH number : 2,...,n

A = 1st to 5th bits including LSB in BSID

B = 1st to 5th bits next to A in BSID

3.4.3 Pilot for DL OFDM

Pilot is used mainly for channel estimation. Pilot symbol is identical to the training symbol in the same subcarrier in a PRU. Pilot symbol shall be boosted by 2.5 dB (=4/3) compared with data symbol.

3.4.3.1 Pilot for DL CCCH

Pilot symbol uses the same training index for CCH. As described in Section 3.4.7.1.1, Pilot

symbols (S3- S19) in the same subcarrier (F7 and F19) copy training symbol S2. Pilot symbols (S5, S9, S13 and S17) in the same subcarrier (F3, F11, F15 and F23) copy training symbol S2.

3.4.3.2 Pilot for DL ICH

ICH is composed of ANCH, EXCH and CSCH. Pilot symbol uses the same training index for ICH. Pilot symbols (S5, S9 S13 and S17) in the same subcarrier (F3, F7, F11, F15, F19 and F23) copy training symbol S1.

3.4.4 Signal for DL OFDM

Figure 3.39 describes the channel coding block diagram for DL signal symbol.

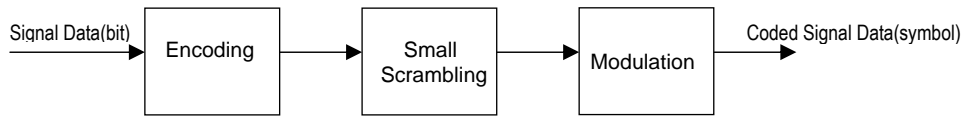

Figure 3.39 Signal Block Diagram

3.4.4.1 Encoding and Small Scrambling

Error correction code method is defined as hamming coding.

Hamming codes can detect and correct 1-bit errors, and can detect (but not correct) 2-bit errors. Hamming codes can work at high speed, because it can be calculated simply. Small scrambling is applied for PAPR reduction.

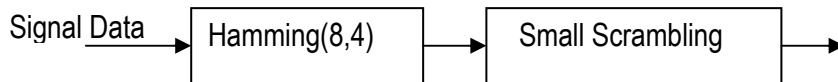

Figure 3.40 Process for Applying Hamming Code and Scrambling for Symbols

3.4.4.1.1 (8,4)-Hamming Coding

Actual data (4 bits)

$$(X_1 \ X_2 \ X_3 \ X_4)$$

Coded data (8 bits)

$$(X_1 \ X_2 \ X_3 \ X_4 \ C_1 \ C_2 \ C_3 \ C_4)$$

Generation polynomial

$$C_1 = X_1 \oplus X_2 \oplus X_3$$

$$C_2 = X_1 \oplus X_2 \oplus X_4$$

$$C_3 = X_1 \oplus X_3 \oplus X_4$$

$$C_4 = X_2 \oplus X_3 \oplus X_4$$

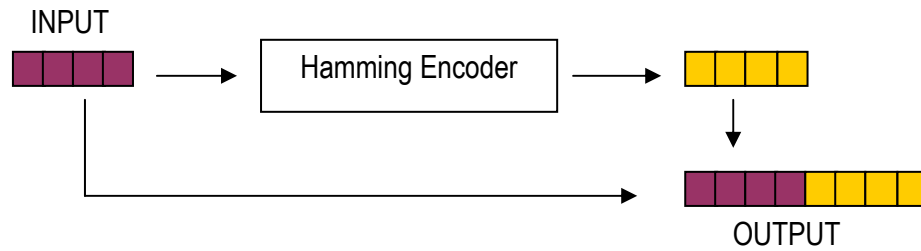

Figure 3.41 Generation Polynomial

3.4.4.1.2 Small Scrambling Pattern

The generation polynomial is defined as follows;

$$X^5 + X^2 + 1$$

Figure 3.42 shows the structure of small scrambling.

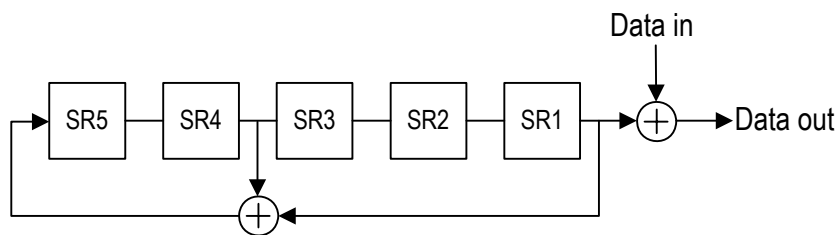

Figure 3.42 Small Scrambling for Hamming Code

Initial values of shift register SR5-SR1 are set to the lower 5 bits of SCH number(*1). The shift register of scrambler is initialized for each Hamming code.

(*1)SCH number : Refer to Section 2.4.3.2.

3.4.4.2 Modulation for Signal

The serial signal input after interleaving is converted to IQ Data symbol on each symbol. The modulation for signal is used as BPSK. Refer to Appendix B.1 for BPSK.

3.4.5 Null (DTX/DC Carrier/Guard carrier) for DL OFDM

Null symbol is defined as $0 + 0j$. It includes Discontinuous Transmission (DTX), DC carrier and

Guard carrier. The details of DTX are described in Section 3.4.1.6.

3.4.6 TCCH Format for DL OFDM

TCCH format is not used for DL.

3.4.7 PRU Structure for DL OFDM

3.4.7.1 CCH for DL OFDM

3.4.7.1.1 OFDM PRU Structure for CCCH

The PRU diagram shown in Figure 3.43 is the diagram about CCCH for DL. As shown in the figure and Table 3.13, CCCH is composed of data symbols, pilot symbols, training symbols and null symbols (DC carrier, guard carrier).

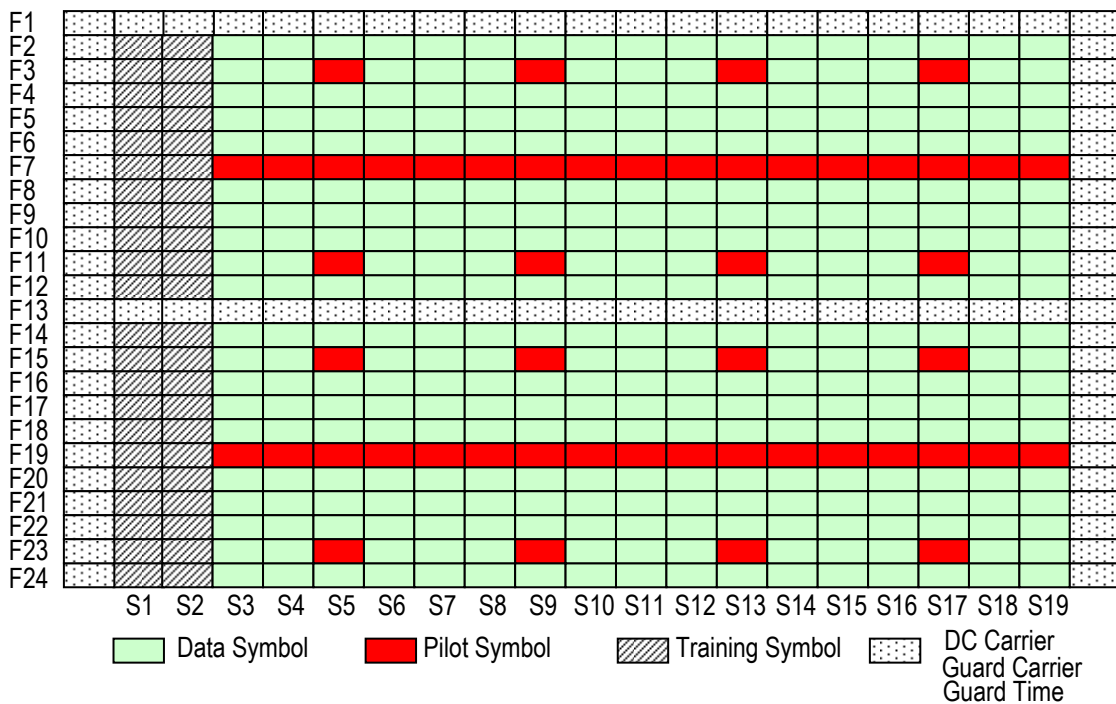

Figure 3.43 OFDM PRU Structure for CCCH

Table 3.13 Composition of CCCH

Symbol Name	Number of Symbols
Data Symbol	324
Training Symbol	44
Pilot Symbol	50
Null Symbol (DC Carrier, Guard Carrier)	38

3.4.7.2 ICH for DL OFDM

3.4.7.2.1 OFDM PRU Structure for ANCH

The PRU diagram shown in Figure 3.44 is the diagram about ANCH for DL. As shown in the figure and Table 3.14, ANCH is composed of data symbols, pilot symbols, training symbols and null symbols (DC carrier, guard carrier).

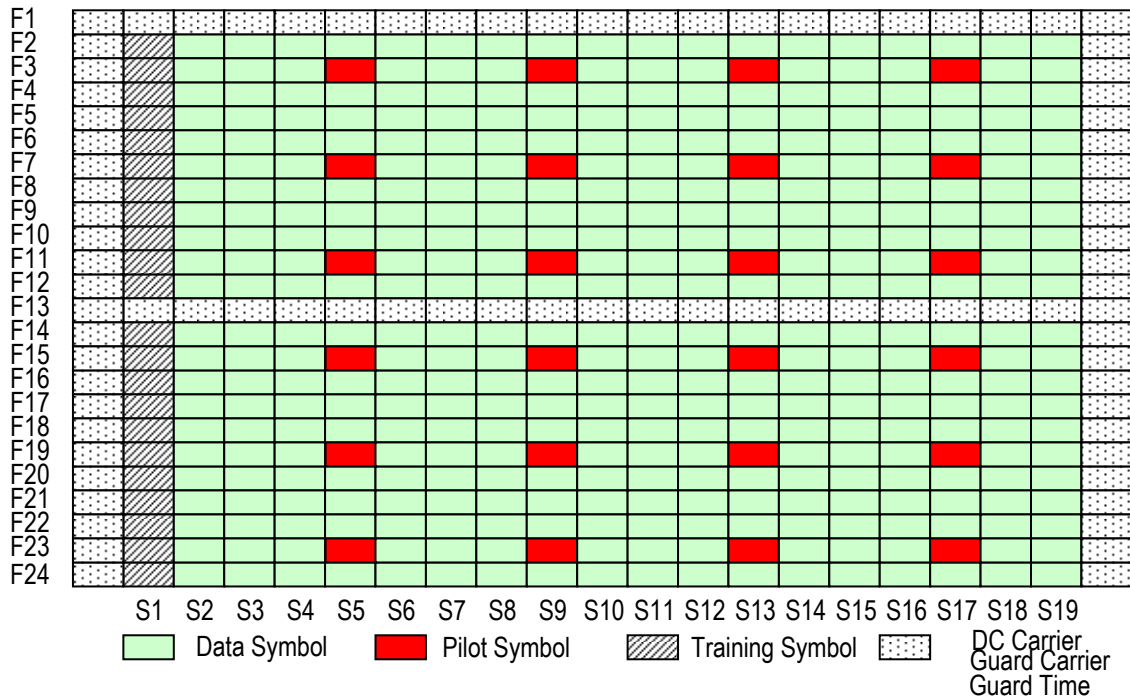

Figure 3.44 OFDM PRU Structure for ANCH

Table 3.14 Composition of ANCH

Symbol Name	Number of Symbols
Data Symbol	372
Training Symbol	22
Pilot Symbol	24
Null Symbol (DC Carrier, Guard Carrier)	38

3.4.7.2.2 OFDM PRU Structure for EXCH

The PRU diagrams shown in Figure 3.45, Figure 3.46, Figure 3.47 and Figure 3.48 are the diagrams about EXCH for DL. As shown in these figures, there are four kinds of EXCH formats. EXCH format (a) has always DC carrier and guard carrier. This format is the case that full subcarrier mode is not used. EXCH formats (b), (c) and (d) are the case that full subcarrier mode is used. EXCH format (b) is used for all SCHs except central SCH to which EXCH format (c) or (d) is applied.

EXCH data size depends on EXCH format and MCS which is indicated by ANCH/ECCH. Moreover, each EXCH data size shall be equal to the number of bits which can be accommodated in one or two PRU.

(a)

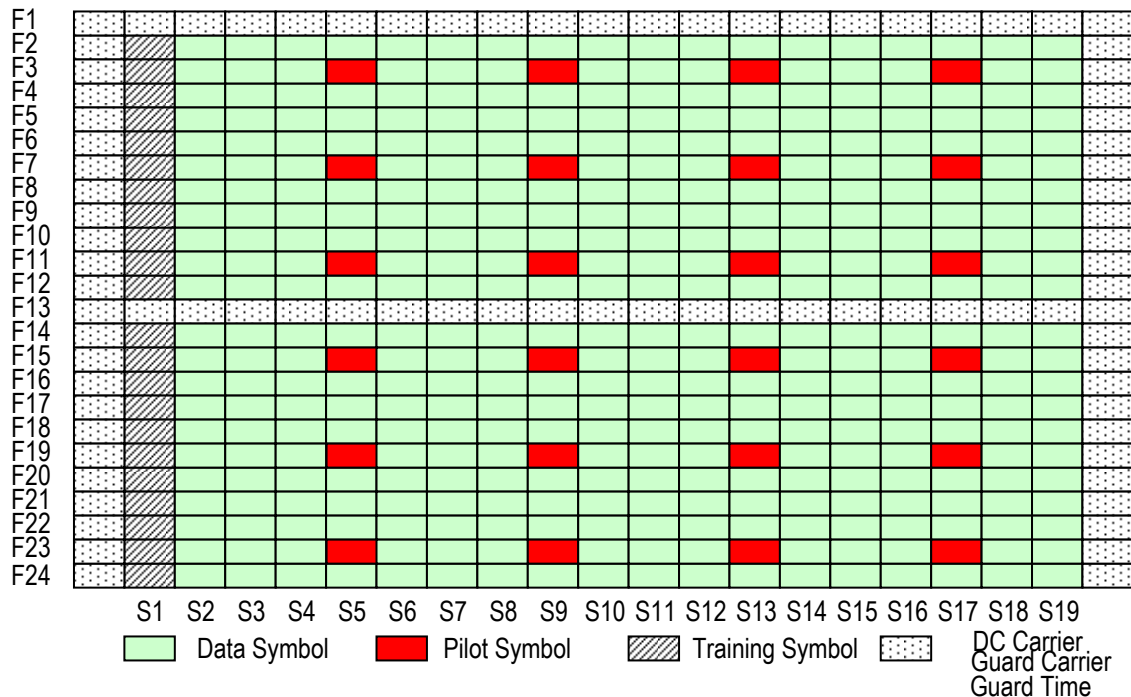

Figure 3.45 OFDM PRU Structure for EXCH (a)

Table 3.15 Composition of EXCH (a)

Symbol Name	Number of Symbols
Data Symbol	372
Training Symbol	22
Pilot Symbol	24
Null Symbol (DC Carrier, Guard Carrier)	38

As shown in Figure 3.46, the training symbol of F1 is a copy of F12. The training symbol of F13 is a copy of F24.

(b)

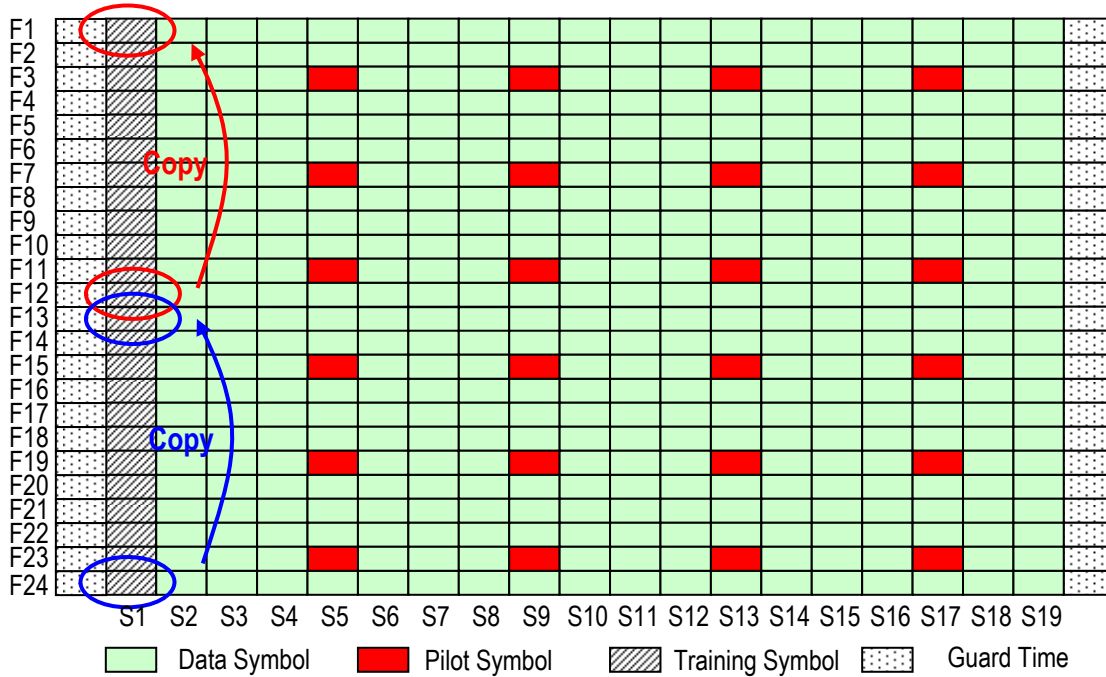

Figure 3.46 OFDM PRU Structure for EXCH (b)

Table 3.16 Composition of EXCH (b)

Symbol Name	Number of Symbols
Data Symbol	408
Training Symbol	24
Pilot Symbol	24
Null Symbol	0

As shown in Figure 3.47, the training symbol of F1 is a copy of F12.

(c)

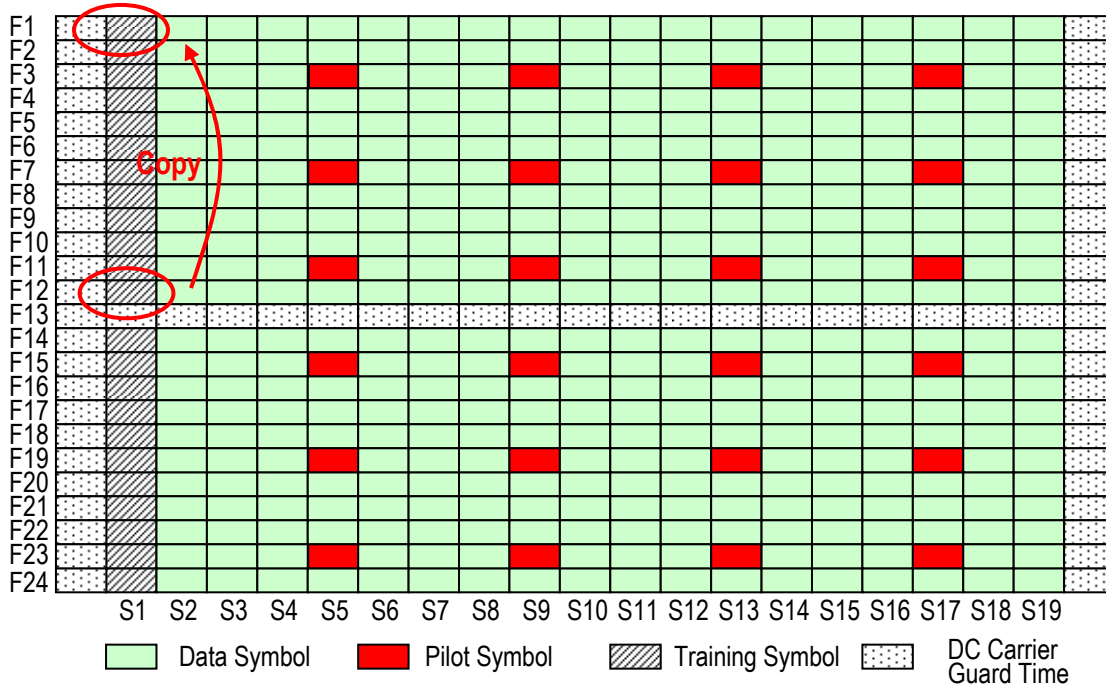

Figure 3.47 OFDM PRU Structure for EXCH (c)

Table 3.17 Composition of EXCH (c)

Symbol Name	Number of Symbols
Data Symbol	390
Training Symbol	23
Pilot Symbol	24
Null Symbol (DC Carrier)	19

As shown in Figure 3.48, the training symbol of F13 is a copy of F24.

(d)

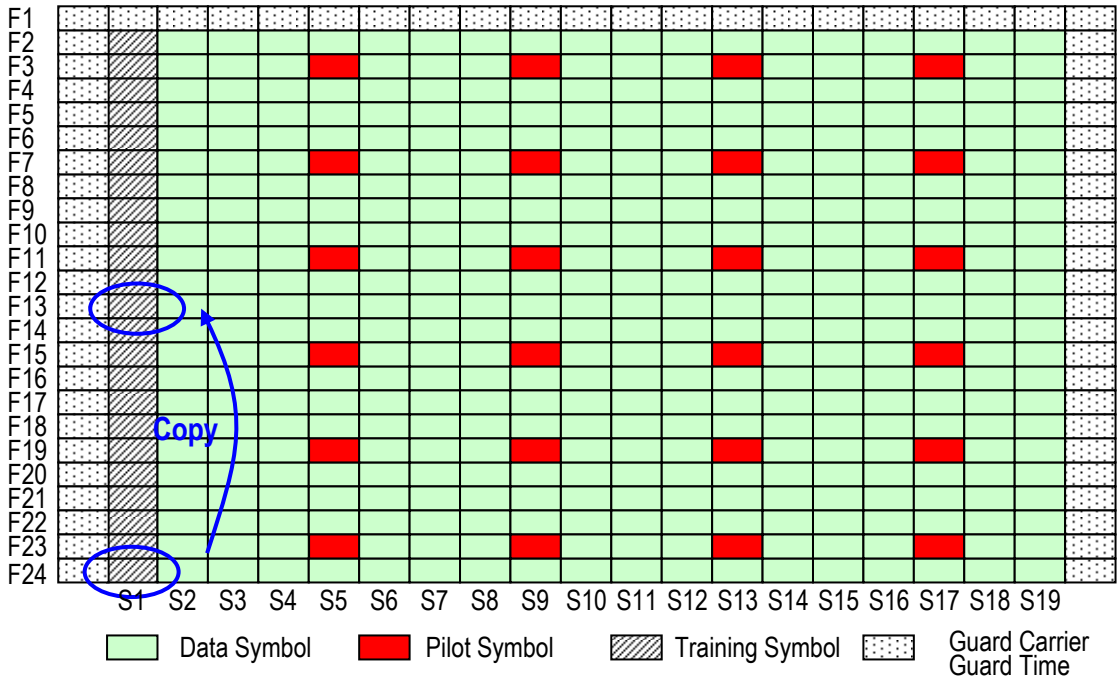

Figure 3.48 OFDM PRU Structure for EXCH (d)

Table 3.18 Composition of EXCH (d)

Symbol Name	Number of Symbols
Data Symbol	390
Training Symbol	23
Pilot Symbol	24
Null symbol (Guard Carrier)	19

3.4.7.2.3 OFDM PRU Structure for CSCH

The PRU diagram shown in Figure 3.49 is the diagram about CSCH for DL. As shown in the figure and Table 3.19, CSCH is composed of data symbols, signal symbols, pilot symbols, training symbols and null symbols (DC carrier, Guard carrier).

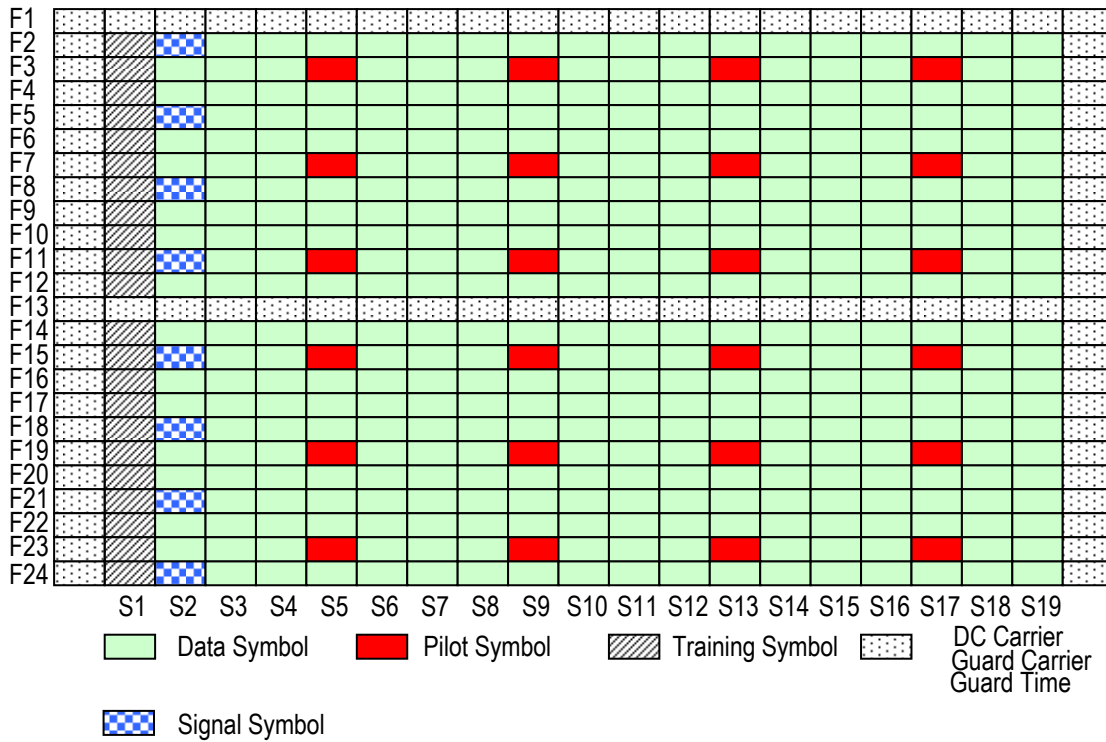

Figure 3.49 OFDM PRU Structure for CSCH

Table 3.19 Composition of CSCH

Symbol Name	Number of Symbols
Data Symbol	364
Signal Symbol	8
Training Symbol	22
Pilot Symbol	24
Null Symbol (DC Carrier, Guard Carrier)	38

3.5 UL OFDM PHY Layer

Figure 3.50 describes a transmitter block diagram for OFDM transmission method.

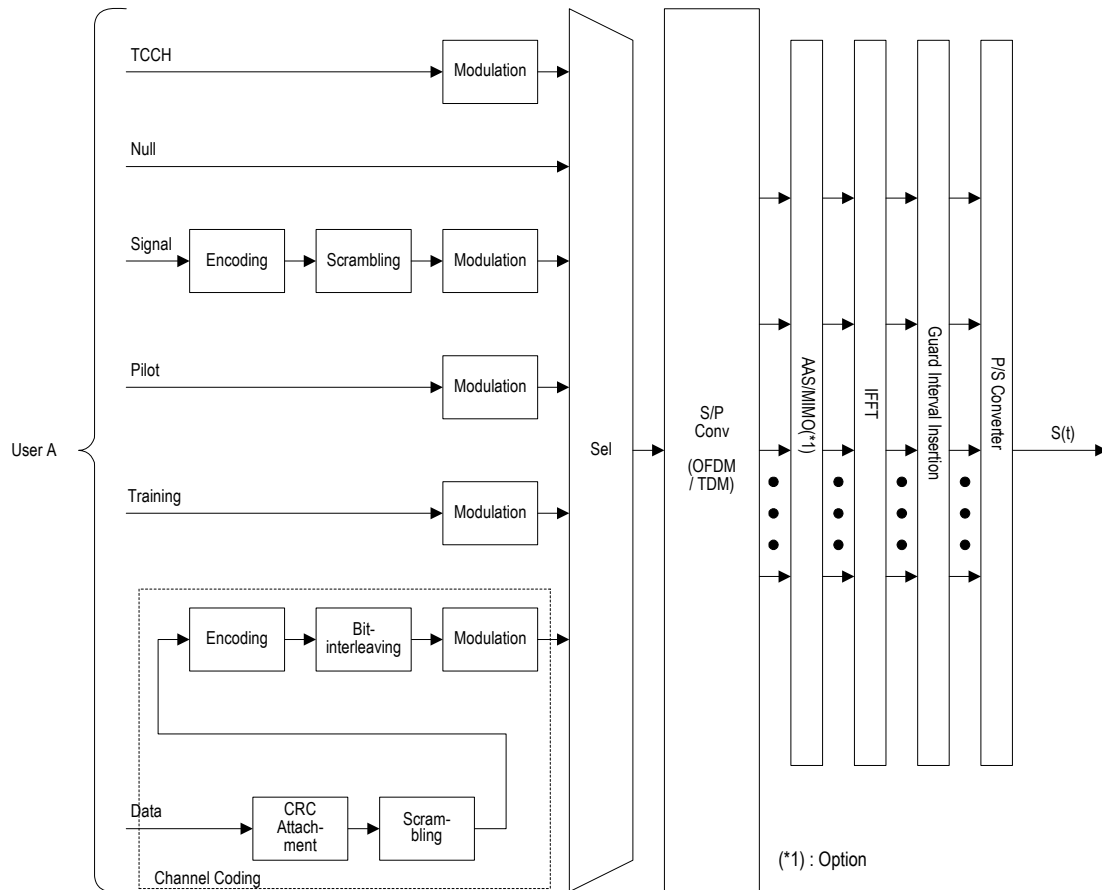

Figure 3.50 Transmitter Block Diagram

3.5.1 Channel Coding for PHY Frame

Refer to Section 3.4.1.

3.5.1.1 CRC

Refer to Section 3.4.1.1.

3.5.1.2 Scrambling

Refer to Section 3.4.1.2.

3.5.1.3 Encoding

Refer to Section 3.4.1.3.

3.5.1.4 Bit-interleaving

Refer to Section 3.4.1.4.

3.5.1.5 Modulation Method

Refer to Section 3.4.1.5.

a) BPSK

Refer to Appendix B.1.

b) QPSK

Refer to Appendix B.3.

c) 16QAM

Refer to Appendix B.6.

d) 64QAM

Refer to Appendix B.7.

e) 256QAM

Refer to Appendix B.8.

3.5.1.6 Symbol Mapping Method to PRU

Refer to Section 3.4.1.6.

3.5.1.7 Summary of OFDM UL Channel Coding

Refer to Section 3.4.1.7.

3.5.2 Training for UL OFDM

Refer to Section 3.4.2.

3.5.3 Pilot for UL OFDM

Refer to Section 3.4.3.

3.5.4 Signal for UL OFDM

Refer to Section 3.4.4.

3.5.5 Null (DTX/DC Carrier/Guard Carrier) for UL OFDM

Refer to Section 3.4.5.

3.5.6 TCCH Format for UL OFDM

3.5.6.1 TCCH Format

TCCH is mainly used to request connection of individual channel from MS to BS, and to correct transmission timing and transmission power according to measurement result at the channel concerned. As shown in Figure 3.51, 3/8 of TCCH original data (the third OFDM data) is copied ahead of the first OFDM data. The phase of this format must be consecutive. As described in Section 3.5.7.1.2, TCCH symbols ($\{S3, S4, S5\}$, $\{S7, S8, S9\}$, $\{S11, S12, S13\}$ and $\{S15, 16, S17\}$) are used for TCCH. TCCH original data (the third OFDM data) is decided by the TCCH core-sequence number as described in Section 3.5.6.2.

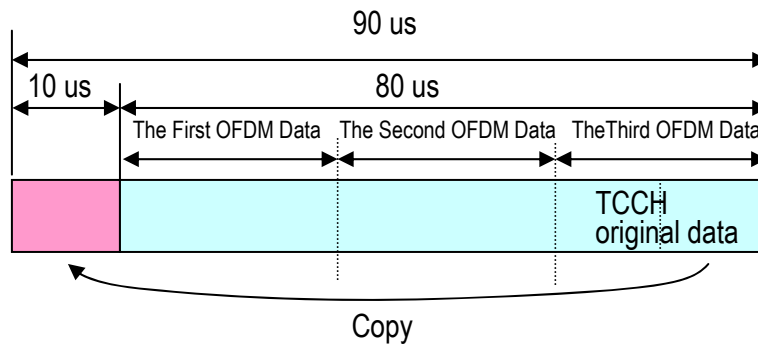

Figure 3.51 TCCH Format for OFDM

3.5.6.2 TCCH Sequence and TCCH Sub-slot

TCCH core-sequence number is described in Appendix D.1. TCCH sub-slots number is described in Section 3.5.7.1.2. The application patterns of TCCH core-sequence number and TCCH sub-slot number are described in Chapter 5.

3.5.7 PRU Structure for UL OFDM

Refer to Section 3.4.7.

3.5.7.1 CCH for UL OFDM

3.5.7.1.1 OFDM PRU Structure for CCCH

Refer to Section 3.4.7.1.1.

3.5.7.1.2 OFDM PRU Structure for TCCH

The PRU diagram shown in Figure 3.52 is the diagram about TCCH for UL. As shown in the figure, there are four sub-slots for TCCH, each of which is composed of three TCCH symbols ({S3, S4, S5}, {S7, S8, S9}, {S11, S12, S13} and {S15, S16, S17}).

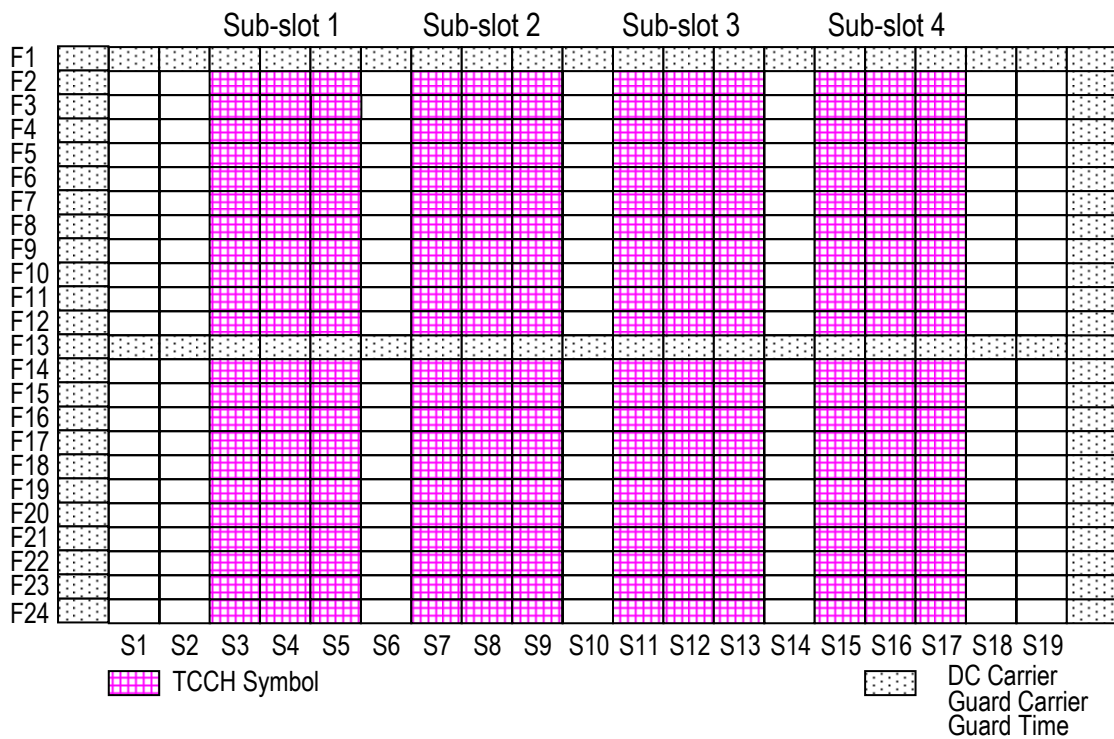

Figure 3.52 OFDM PRU Structure for TCCH

Table 3.20 Composition of TCCH

Symbol Name	Number of Symbols
TCCH Symbol	66 x 4 sub-slots

3.5.7.2 ICH for UL OFDM

3.5.7.2.1 OFDM PRU Structure for ANCH

Refer to Section 3.4.7.2.1.

3.5.7.2.2 OFDM PRU Structure for EXCH

The PRU diagram in shown Figure 3.53 is the diagrams about EXCH for UL. As shown in the figure and Table 3.21, EXCH is composed of data symbols, pilot symbols, training symbols and null symbols (DC carrier, guard carrier). BPSK, QPSK, 16QAM, 64QAM and 256QAM are used for the data symbol. Note that full subcarrier mode is not used for UL.

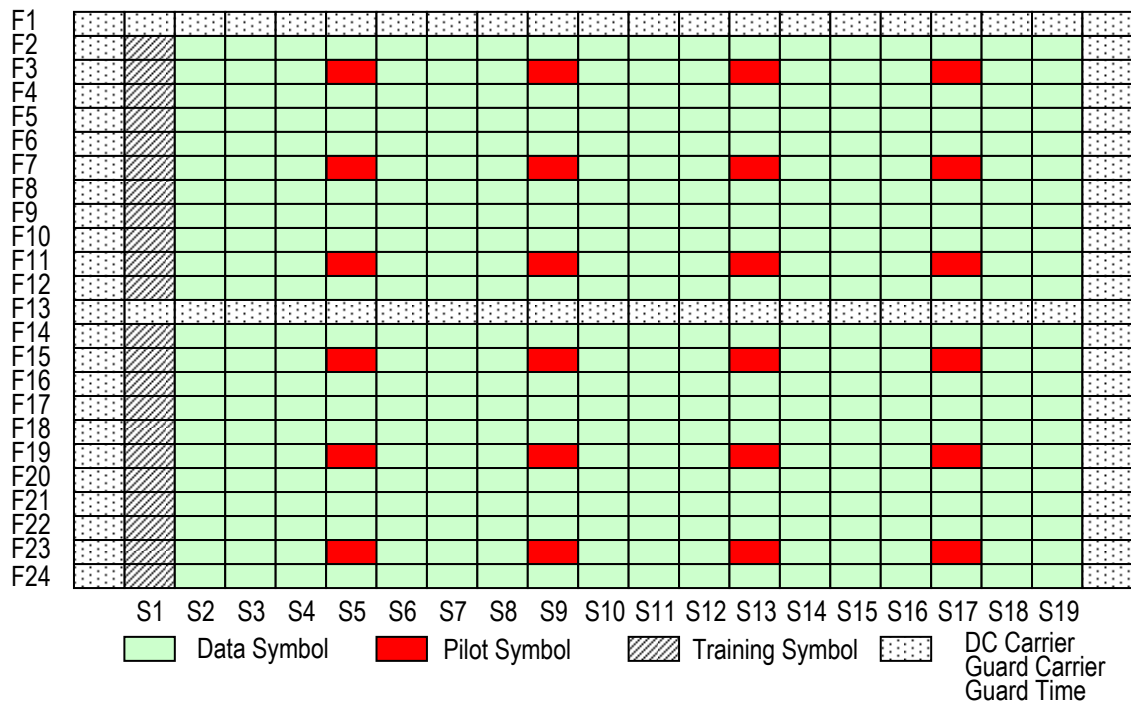

Figure 3.53 OFDM PRU Structure for EXCH

Table 3.21 Composition of EXCH

Symbol Name	Number of Symbols
Data Symbol	372
Training Symbol	22
Pilot Symbol	24
Null Symbol (DC carrier, Guard Carrier)	38

3.5.7.2.3 OFDM PRU Structure for CSCH

Refer to Section 3.4.7.2.3.

3.6 UL SC PHY Layer

Figure 3.54 describes a transmitter block diagram for SC transmission method.

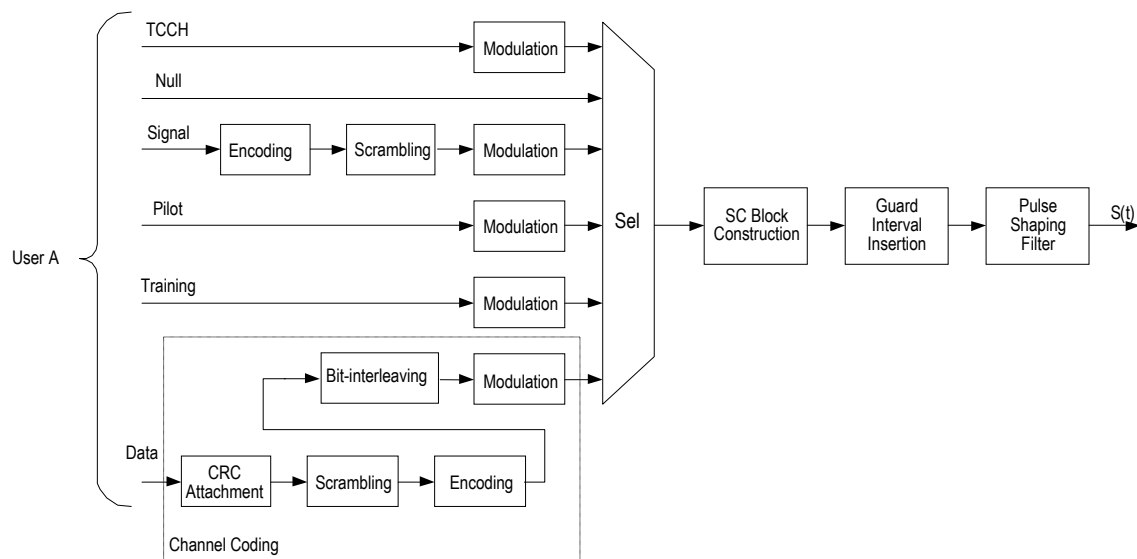

Figure 3.54 Transmitter Block Diagram for SC Transmission Method

3.6.1 Channel Coding for PHY Frame

PHY frame consists of one or more Cyclic Redundancy Check (CRC) data unit(s). CRC-bits are first appended to the CRC data unit. Then tail-bits are appended to the CRC data unit with CRC-bits after performing scrambling. CRC unit is defined as the scrambled CRC data unit with CRC-bits and tail-bits. The size of CRC unit is described in Section 3.6.6.3. The CRC unit is encoded according to error correction code. Then, bit-interleaving is performed for error correction coded bits. When performing bit-interleaving, rate matching shall be applied by puncturing some of coded bits if virtual GI extension is used. Then, the output bits of bit-interleaving are converted to IQ signals by modulation method.

Figure 3.55 describes the channel coding block diagram for UL SC from Figure 3.54.

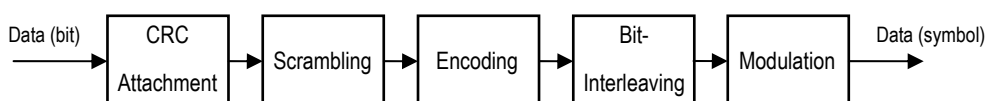

Figure 3.55 Channel Coding for SC

3.6.1.1 CRC

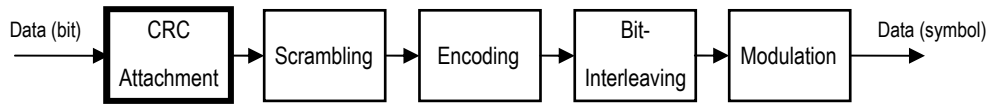

Figure 3.56 CRC Attachment

Refer to Section 3.4.1.1.

3.6.1.2 Scrambling

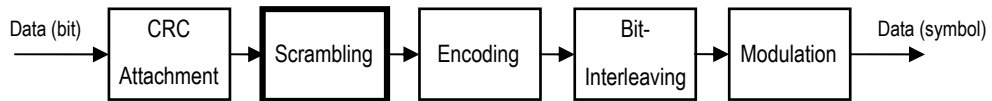

Figure 3.57 Scrambling

Refer to Section 3.4.1.2.

3.6.1.3 Encoding



Figure 3.58 Encoding

Refer to Section 3.4.1.3.

3.6.1.4 Bit-interleaving

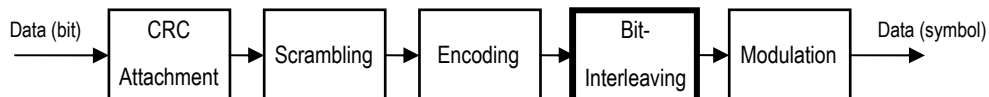

Figure 3.59 Bit-interleaving

3.6.1.4.1 Bit-interleaver Structure

Refer to Section 3.4.1.4.1.

3.6.1.4.2 Block Interleaver Method

Refer to Section 3.4.1.4.2.

3.6.1.4.3 Interleaver Parameters for UL SC

Table 3.22 to Table 3.25 summarize the parameters of the interleaver for input bit size and modulation class. In Table 3.25, position to start reading (A) is used when the puncturing rate R_2 is 1 or 4/6 at the convolutional encoder. Position to start reading (B) is used when the puncturing rate R_2 is 3/4 or 6/10 at the convolutional encoder.

Table 3.22 Interleaver Parameter M and N

Physical Channel	Number of Symbols: y	M	N
CCH	240	15	16
ICH (One PRU)	256	16	16
ICH (Otherwise)	512	32	16

Table 3.23 Interleaver Parameter

Modulation	The Number of Block Interleavers
BPSK	1
QPSK	2
8PSK	3
16QAM	4
64QAM	6
256QAM	8

Table 3.24 The Definition of Bit Position i in a Symbol

Modulation	Bit Position i in a Symbol
BPSK	i = (1)
QPSK	i = (1,2)
8PSK	i = (1,2,3)
16QAM	i = (1,2,3,4)
64QAM	i = (1,2,3,4,5,6)
256QAM	i = (1,2,3,4,5,6,7,8)

Table 3.25 Starting Position for Interleaver

Bit Position i in a Symbol	Position to Start Writing	Position to Start Reading (A)	Position to Start Reading (B)
1	a _{1,1}	a _{1,1}	a _{1,1}
2	a _{1,1}	a _{1,2}	a _{1,1}
3	a _{1,1}	a _{1,3}	a _{1,2}
4	a _{1,1}	a _{1,4}	a _{1,2}
5	a _{1,1}	a _{1,8}	a _{1,2}
6	a _{1,1}	a _{1,9}	a _{1,1}
7	a _{1,1}	a _{1,10}	N/A
8	a _{1,1}	a _{1,7}	N/A

3.6.1.4.4 Rate Matching Method

Rate matching is applied only when the virtual GI extension is used for SC. Table 3.26 shows the matching rate of Rate Matching (R_m) for different symbol rates. Figure 3.60 shows the deleting bit positions of rate matching for CCH defined in the form of block interleaver matrix of 16-column and 15-row ($N=16$, $M=15$). Figure 3.61 shows the deleting bit positions of rate matching pattern A for ICH in the form of block interleaver matrix of 16-column and 16-row ($N=16$, $M=16$). Figure 3.62 to Figure 3.64 show the deleting bit positions of rate matching pattern B1 to B3 for ICH in the form of block interleaver matrix of 16-column and 16-row, respectively.

For ICH, when the puncturing rate R_2 is 1 or 4/6 at convolutional encoder, pattern A is used. When the puncturing rate R_2 is 3/4 or 6/10 at convolutional encoder, patterns B1, B2 and B3 are periodically used in an order such as B1 for the first block interleaver, B2 for the second block interleaver, B3 for the third block interleaver and so on.

When the number of input bits is 512, two rate matching patterns are simply concatenated to define the pattern for the block interleaver of 16-column and 32-row ($N=16$ and $M=32$). When using pattern B1, B2 and B3, appropriate pairs are (B1, B2), (B3, B1) and (B2, B3). These pairs (B1, B2), (B3, B1) and (B2, B3) are periodically used in an order such as (B1, B2) for the first block interleaver, (B3, B1) for the second block interleaver, (B2, B3) for the third block interleaver and so on. The pattern (Bi, Bj) means that Bi spans the first 16-row and Bj spans the last 16-row of the block interleaver matrix.

Table 3.27 to Table 3.29 summarize the deleting bit numbers when $a_{1,1}$ is the starting position to read out of the block interleaver. When the coding rate R is 7/8 at the convolutional encoder, virtual GI extension is not applied.

Table 3.26 Rate Matching Parameters

Parameter		Type1	Type2
Symbol Rate [MSPS]		0.6	1.2
Matching Rate: R_m	CCH	206/240	N/A
	ICH	220/256	238/256

(*) N/A: Not Available

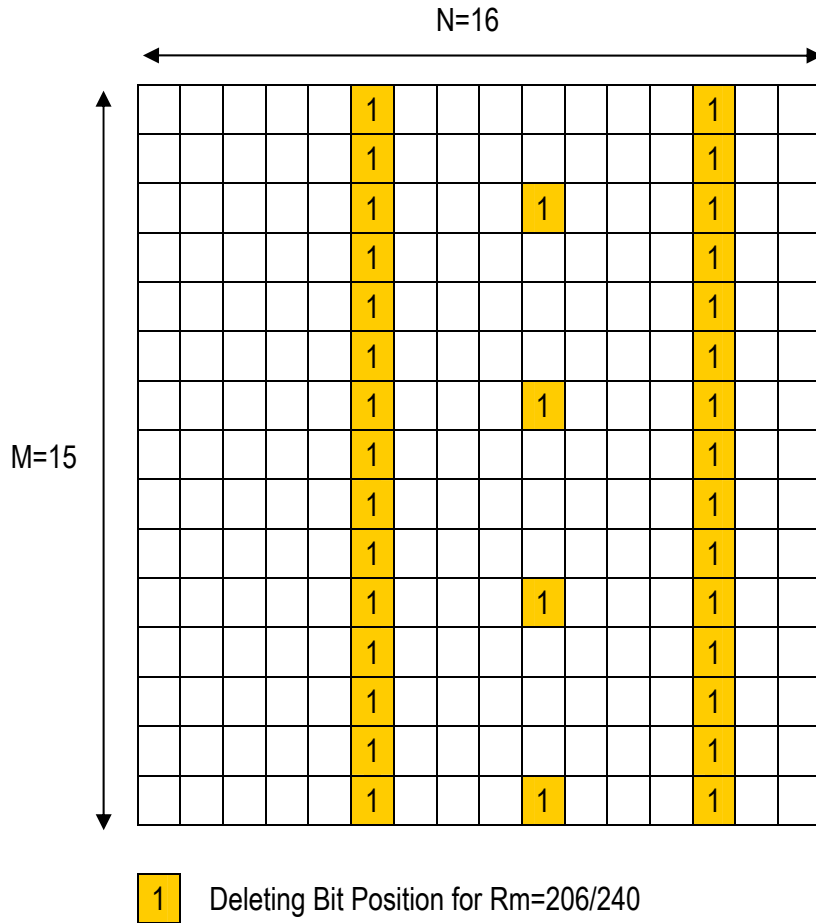

Figure 3.60 Deleting Bit Position for CCH: Pattern A

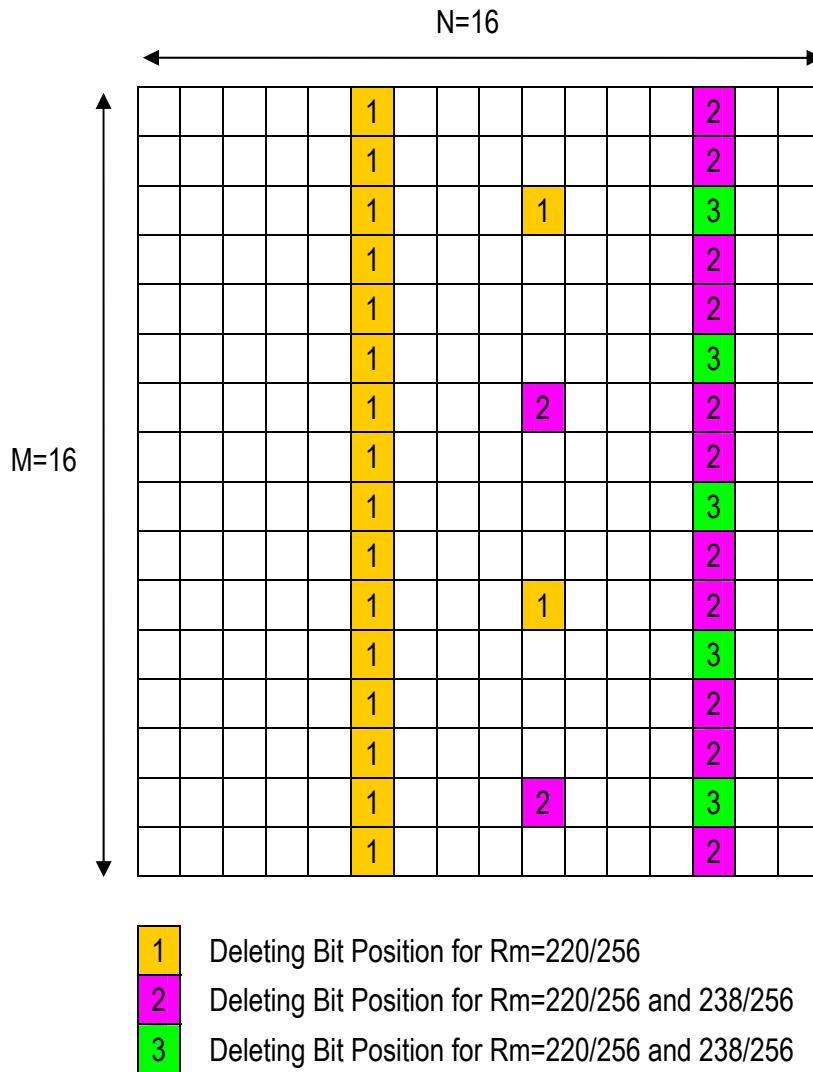

Figure 3.61 Deleting Bit Position for ICH: Pattern A

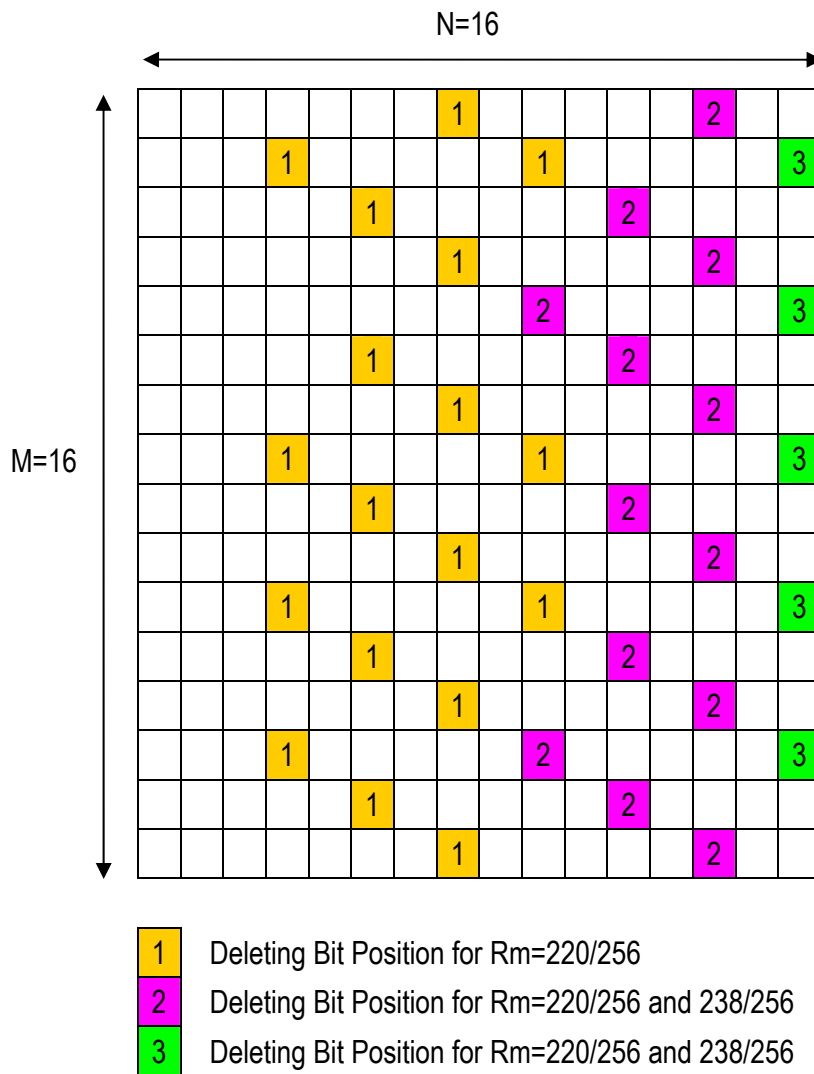

Figure 3.62 Deleting Bit Position for ICH: Pattern B1

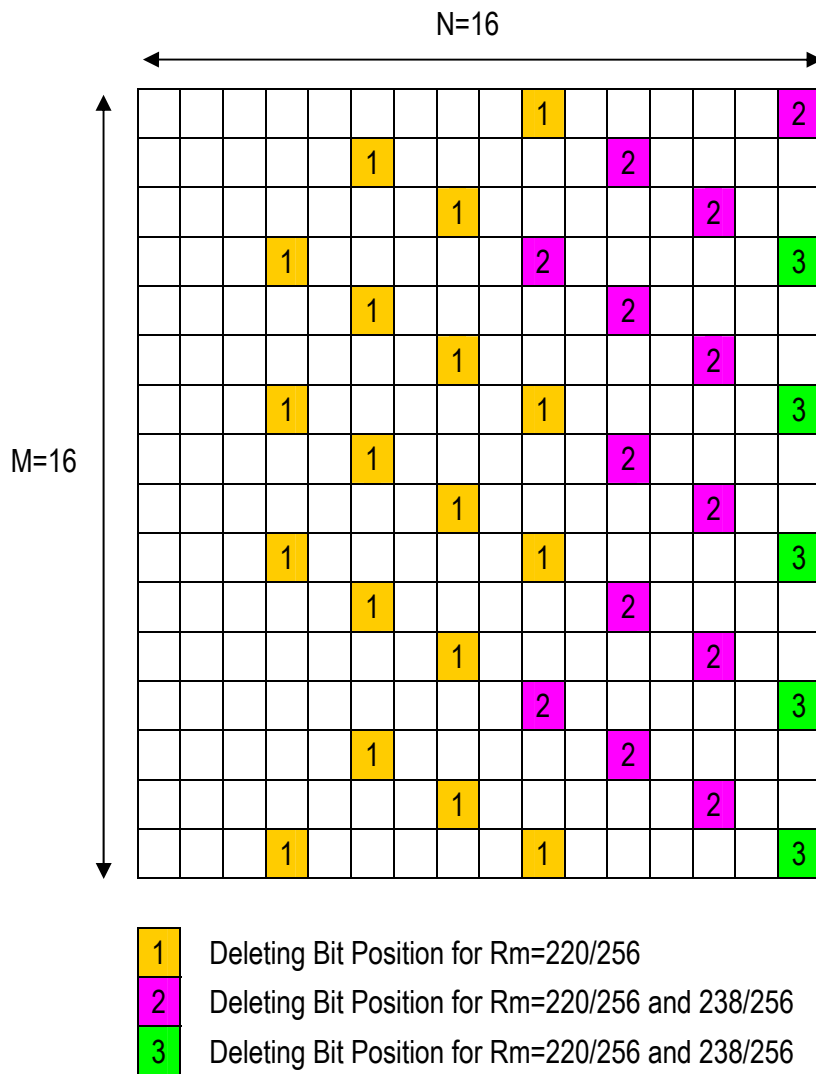

Figure 3.63 Deleting Bit Position of ICH: Pattern B2

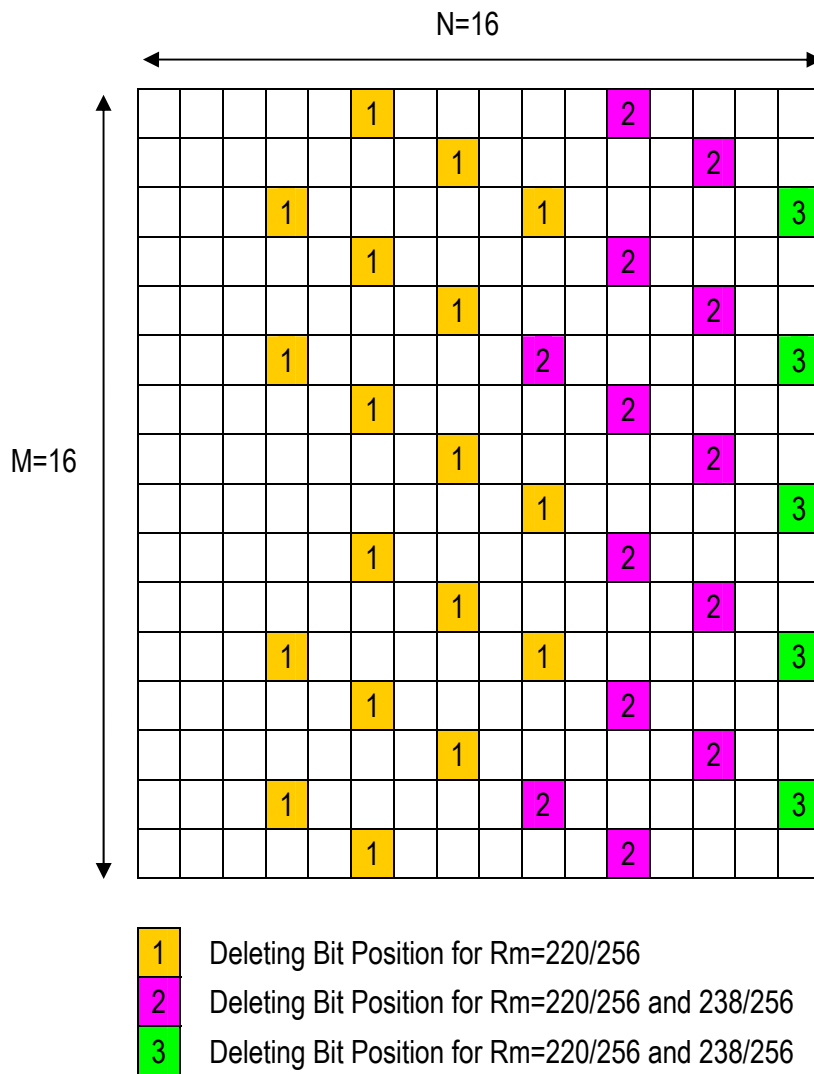

Figure 3.64 Deleting Bit Position of ICH: Pattern B3

Table 3.27 Rate Matching Pattern for CCH

Rm	Puncturing Rate @CC	Pattern	Deleting Bit Number (1 - 240)
206/240	1	A	76-90, 138, 142, 146, 150, 196-210

Table 3.28 Rate Matching Pattern 1 for ICH

Rm	Puncturing Rate @CC	Pattern	Deleting Bit Number (1 - 256)
220/256	1, 4/6	A	81-96, 147, 151, 155, 159, 209-224
	3/4, 6/10	B1	50, 56, 59, 62, 83, 86, 89, 92, 95, 113, 116, 119, 122, 125, 128, 146, 149, 152, 155, 158, 179, 182, 185, 188, 191, 209, 212, 215, 218, 221, 224, 242, 245, 248, 251, 254
		B2	52, 55, 58, 64, 82, 85, 88, 91, 94, 115, 118, 121, 124, 127, 145, 148, 151, 154, 157, 160, 178, 181, 184, 187, 190, 211, 214, 217, 220, 223, 241, 244, 247, 250, 253, 256
		B3	51, 54, 60, 63, 81, 84, 87, 90, 93, 96, 114, 117, 120, 123, 126, 147, 150, 153, 156, 159, 177, 180, 183, 186, 189, 192, 210, 213, 216, 219, 222, 243, 246, 249, 252, 255

Table 3.29 Rate Matching Pattern 2 for ICH

Rm	Puncturing Rate @CC	Pattern	Deleting Bit Number (1 - 256)
238/256	1, 4/6	A	151, 159, 209-224
	3/4, 6/10	B1	149, 158, 179, 182, 185, 188, 191, 209, 212, 215, 218, 221, 224, 242, 245, 248, 251, 254
		B2	148, 157, 178, 181, 184, 187, 190, 211, 214, 217, 220, 223, 241, 244, 247, 250, 253, 256
		B3	150, 159, 177, 180, 183, 186, 189, 192, 210, 213, 216, 219, 222, 243, 246, 249, 252, 255

3.6.1.4.5 Output-bits After Bit-interleaver

The IQ data symbol is generated by using x bits, each of which is taken from each block interleaver after applying the rate matching. Denote the output bits from i -th block interleaver by $z(i,1), z(i,2), \dots, z(i,y')$, where y' is $R_m \cdot y$ with rate matching or y' is y without rate matching. Thus, the j -th IQ data symbol is converted from the bit series $z(p_1,j), z(p_2,j), \dots, z(p_x,j)$, where p_i is a offset value to circulate the order of input bits to the modulator, and is defined as follows:

Input bits to the modulator: $z(p_1,j), z(p_2,j), \dots, z(p_x,j)$

Offset value: $p_i = (i+j-2) \bmod x + 1$

3.6.1.5 Modulation Method

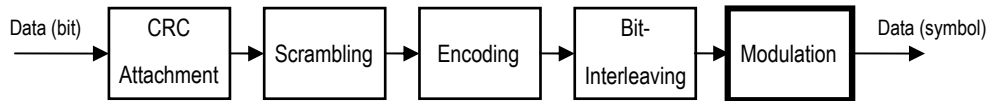

Figure 3.65 Modulation

The serial signal input after interleaving is converted to IQ Data symbol on each symbol. The modulation ($\pi/2$ -BPSK, $\pi/4$ -QPSK, 8PSK, 16QAM, 64QAM and 256QAM) is shown in Appendix B.

a) $\pi/2$ -BPSK

Refer to Appendix B.2.

b) $\pi/4$ -QPSK

Refer to Appendix B.4.

c) 8PSK

Refer to Appendix B.5.

d) 16QAM

Refer to Appendix B.6.

e) 64QAM

Refer to Appendix B.7.

f) 256QAM

Refer to Appendix B.8.

3.6.1.6 Symbol Mapping Method for Data Block

Symbol mapping methods depend on the types of physical channel (CCH, ANCH, EXCH and CSCH). The detail of the mapping method is described below.

3.6.1.6.1 Data Block

Figure 3.66 illustrates a data block structure for UL SC. Data block is a SC block composed of data symbols, in which N is the SC block size and $G1$ is the GI size. Data symbol mapping is performed by aligning the data symbols along the time axis. That is, data symbols from the modulator are mapped into the SC block by the order of $D(1)$, $D(2)$, ..., $D(N)$.

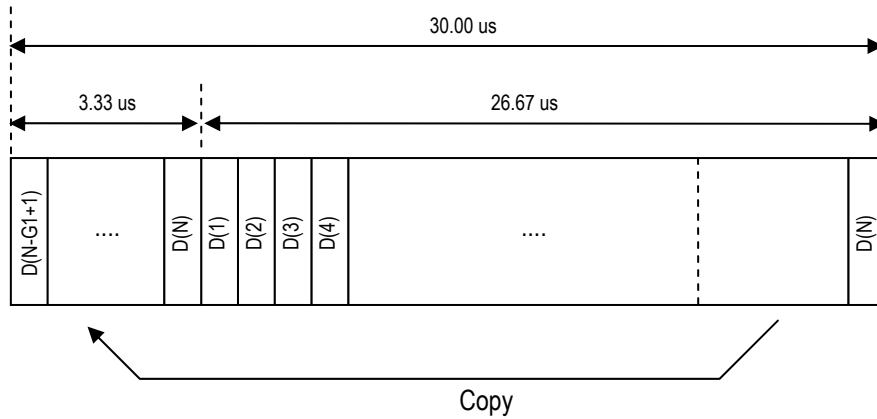

Figure 3.66 Symbol Mapping onto SC Block without Virtual GI Extension

3.6.1.6.2 Data Block with Virtual GI Extension

When the virtual GI extension is used, some symbols in the preceding SC block are copied into a data block. Figure 3.67 shows the SC block format (n -th SC block) in the case that virtual GI extension is used for data blocks (except for S8 and S16). In addition to this, data blocks S8 and S16 include copies of the pilot symbols from S9 and S17 respectively with virtual GI extension. Figure 3.68 shows the SC block format (n -th SC block) with virtual GI extension for data blocks S8 and S16. Parameters for virtual GI extension are summarized in Table 3.30. Virtual GI length is defined as the time length of SC block to which preceding or succeeding SC block is copied. Virtual GI size is defined as the number of symbols in the virtual GI length.

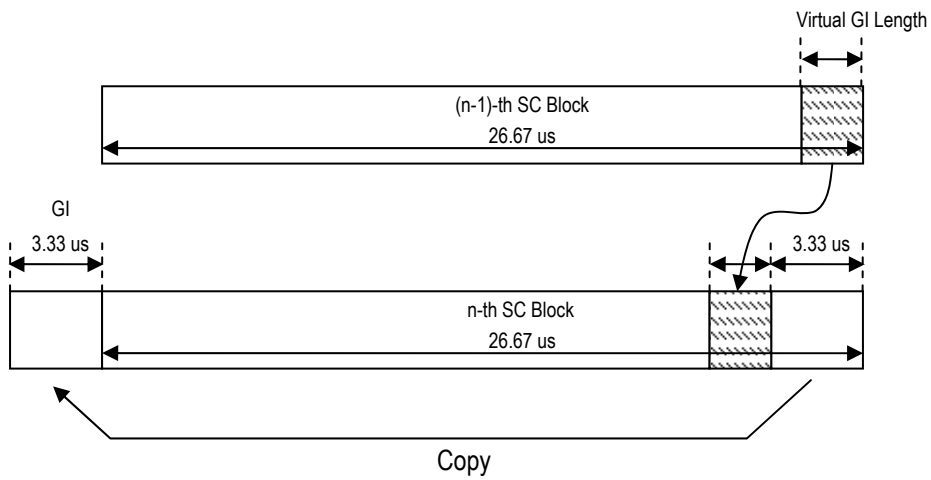

Figure 3.67 Symbol Mapping of SC Block with Virtual GI Extension (Data Blocks Except for S8 and S16)

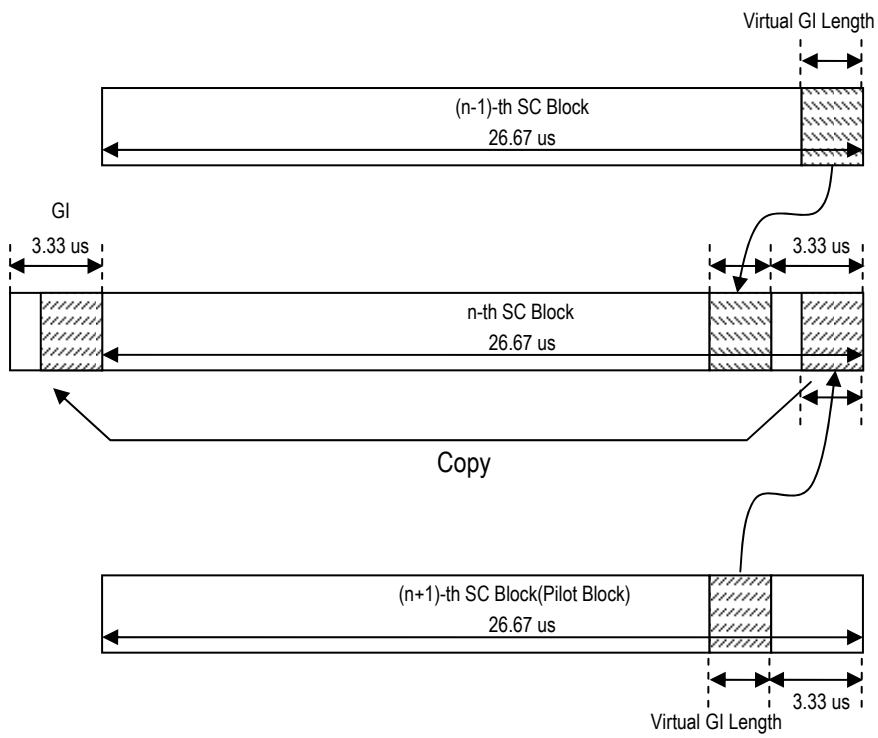

Figure 3.68 Symbol Mapping of SC Block with Virtual GI Extension (S8 and S16)

Table 3.30 Parameters for Virtual GI Extension for UL SC

Parameter	Type 1	Type 2
Symbol Rate [MSPS]	0.6	1.2
Virtual GI Length [us]	3.33	1.67
Virtual GI Size [symbol]	2	2

3.6.1.7 Summary of SC UL Channel Coding

Combinations of coding and modulation are shown in Table 3.31 for UL SC. Efficiency of each combination is shown in the same table. Efficiency is defined as the number of information bits carried by one data symbol in the SC burst. Efficiency and total coding rate are calculated assuming no virtual GI extension in the table. Note that actual efficiency becomes higher with virtual GI extension.

Table 3.31 Summary of UL SC Channel Coding

Modulation	Scaling Factor	Coding Rate @Convolutional Coding	Puncturing Rate R2	Total Coding Rate R	Efficiency
$\pi/2$ -BPSK	1	$1/2$	1	1/2	0.5
			3/4	2/3	0.67
$\pi/4$ -QPSK	$1/\sqrt{2}$		1	1/2	1
			4/6	3/4	1.5
8PSK	1		3/4	2/3	2
16QAM	$1/\sqrt{10}$		1	1/2	2
			4/6	3/4	3
64QAM	$1/\sqrt{42}$		3/4	4/6	4
			6/10	5/6	5
256QAM	$1/\sqrt{170}$		4/6	6/8	6
		8/14	7/8	7	

3.6.2 Training for UL SC

Training block is a SC block used mainly for synchronization, frequency offset estimation, automatic gain control or weight calculation of beam-forming. Training block is composed of predefined data (Refer to Appendix C.2). The details of training block, training sequence and training pattern are described in Sections 3.6.2.1, 3.6.2.2, and 3.6.2.3.

3.6.2.1 Training Block Format

Training block is constructed by training symbols, T(1) – T(N) as defined in Appendix C.2. Training symbols are chosen according to the training index as defined in Section 3.6.2.3.

3.6.2.1.1 Training Format for ICH

Figure 3.69 illustrates the training block format for ICH, in which N is the SC block size and G2 is the GI size. In case of ICH, training data is the first SC block S1.

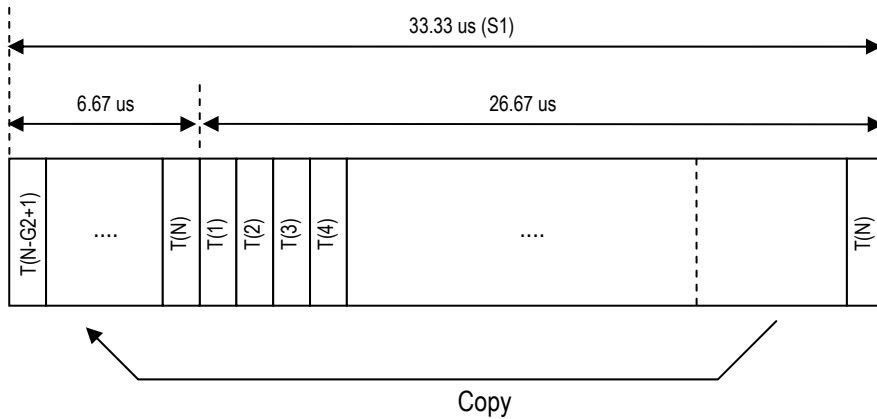

Figure 3.69 Training Format for ICH

3.6.2.1.2 Training Format for CCCH

Figure 3.70 illustrates the training format for CCCH. In case of CCCH, two training blocks S1 and S2 are used. Training symbols, T(1) – T(16), are mapped into S1 and S2 so that the training sequence repeats itself during the two SC blocks (S1 and S2) as shown in the figure.

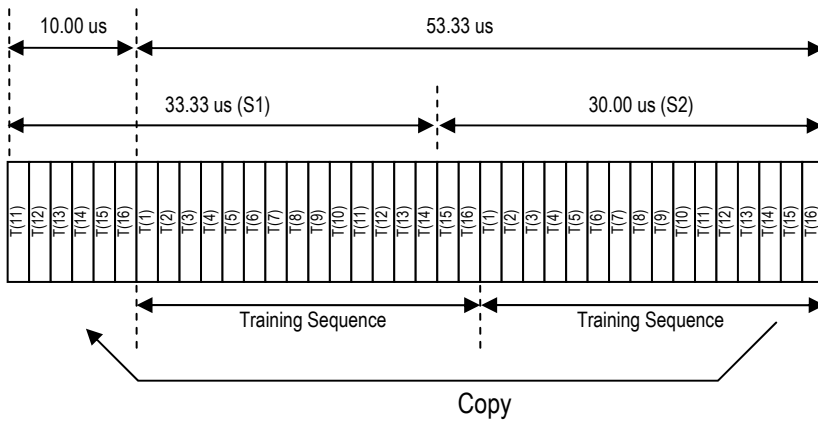

Figure 3.70 Training format for CCH

3.6.2.2 Training Sequence

Refer to Appendix C.2 for training sequence and offset values.

Eight core-sequences are defined in Table C.5 to Table C.10. These core-sequences are on the constellation of 8PSK or 16PSK as shown in Appendix B.5 or Appendix B.9. In addition to these core-sequences, cyclic-shifted versions of them are also used for constructing training for ICH and CCH as shown in Table C.12.

3.6.2.3 Training Index

As described in Section 3.6.2.2, there are 8 core-sequences and offset values (cyclic-shift values). Training index is numbered as follows:

$$\text{Training Index} = \text{Core-sequence Number} + (\text{Offset Value Number}-1)*8$$

3.6.2.3.1 Training Index for CCCH

Training index, core-sequence number and offset value number for CCH are defined as follows:

Training Index	: 2
Core-sequence Number	: 2
Offset Value Number	: 1

3.6.2.3.2 Training Index for ICH

ICH is composed of ANCH, EXCH and CSCH. Training index, core-sequence number and offset value number for ICH are defined as follows:

Training Index	: $x + (y-1)*8$
Core-sequence Number	: $x=[A \text{ MOD } 8]+ 1$
Offset Value Number	: $y=[\{B+m\} \text{ MOD } (n-1)]+ 2$

n = maximum number of SCHs in a slot

m = the smallest SCH number assigned to the MS in the slot ($m=2,3,\dots$)

A = 1st to 5th bits including LSB in BSID

B = 1st to 5th bits next to A in BSID

Training index, core-sequence number and offset value number for MIMO are defined as follows:

Training Index	: $x + (y-1)*8$
Core-sequence Number	: $x=[\{A+k-1\} \text{ MOD } 8]+ 1$
Offset Value Number	: $y=[\{B+m\} \text{ MOD } (n-1)]+ 2$

k =MIMO stream number ($k=1,2,\dots$)

n = maximum number of SCHs in a slot

m = the smallest SCH number assigned to the MS in the slot ($m=2,3,\dots$)

A = 1st to 5th bits including LSB in BSID

B = 1st to 5th bits next to A in BSID

3.6.3 Pilot for UL SC

Figure 3.71 illustrates a pilot block format. Pilot block is a SC block used mainly for channel estimation. Pilot block consists of N pilot symbols, $P(1) - P(N)$, as shown in this figure.

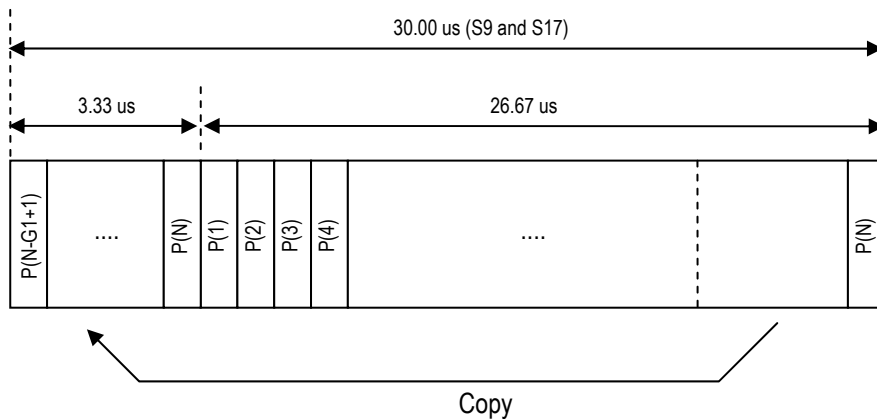

Figure 3.71 Pilot Block Format

3.6.3.1 Pilot Index

Pilot index is defined by eight core-sequences and offset values (cyclic-shift value) in the same way as training index described in Section 3.6.2.3. Pilot index is numbered as follows:

$$\text{Pilot index} = \text{core-sequence number} + (\text{offset value number}-1)*8$$

3.6.3.2 Pilot for CCCH

SC burst for CCCH has two pilot blocks at S9 and S17. Pilot block consists of 16 pilot symbols. Pilot symbols P(1) – P(16) in the both pilot blocks (S9 and S17) are the same as training symbols T(1) – T(16) in the training block S2 respectively. Pilot index is the same as training index in the same SC burst.

3.6.3.3 Pilot for ICH

3.6.3.3.1 Pilot for ANCH

SC burst for ANCH has two pilot blocks at S9 and S17. Pilot block consists of 16 pilot symbols. Pilot symbols P(1) – P(16) in both pilot blocks (S9 and S17) are the same as training symbols T(1) – T(16) in the training block S1 correspondingly. Pilot index is the same as training index in the same SC burst.

3.6.3.3.2 Pilot for EXCH

SC burst for EXCH has two pilot blocks at S9 and S17. Pilot block consists of 16 pilot symbols. Pilot symbols P(1) – P(N) in the both pilot blocks (S9 and S17) are the same as training symbols T(1) – T(N) in the training block S1 correspondingly. Pilot index is the same as training index in the same SC burst.

3.6.3.3.3 Pilot for CSCH

SC burst for CSCH has two pilot blocks at S9 and S17. Pilot symbols $P(1) - P(N)$ in the pilot block S17 are the same as training symbols $T(1) - T(N)$ in the training block S1 correspondingly. Pilot block S9 is different from as S17 for CSCH. For the symbol rate of 0.6 Msps ($N=16$), pilot symbols $P(1) - P(N)$ in S9 are selected from Table C.5 in Appendix C.2 with the same pilot index. For 1.2 Msps and above ($N \geq 32$), pilot symbols in S9 are constructed by repeating the pilot block of half-length ($N/2$) with the same pilot index twice. Pilot block S9 is then modulated in order to multiplex signaling bits as described in Section 3.6.4.2.

3.6.4 Signal for UL SC

Figure 3.72 describes the coding block diagram for signal data for UL SC.

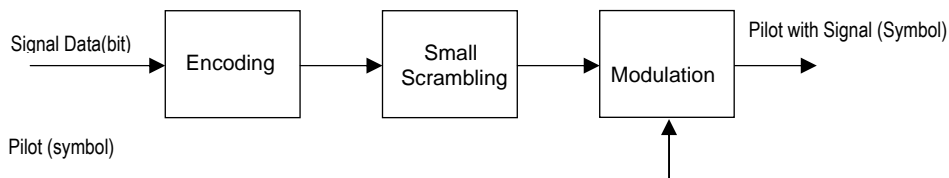

Figure 3.72 Signal Encoding Block Diagram for UL SC

3.6.4.1 Signal Encoding

Figure 3.73 illustrates the signal encoding for SC, which consists of (8,4) Hamming encoding and repetition process. Table 3.32 summarizes the parameters for signal encoding for each symbol rate. In this figure, signal data (4-bit) is first encoded by (8,4) Hamming encoding, and then repeated r_1 times.

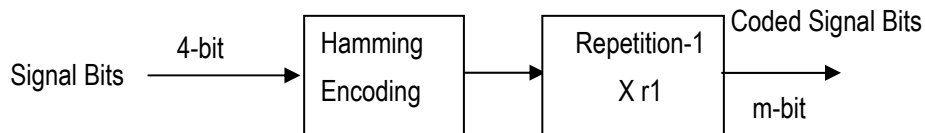

Figure 3.73 Signal Encoding for SC

Table 3.32 Parameters for Signal Encoding

	Type1	Type2
Symbol Rate [MSPS]	0.6	1.2
Number of Signal Bits	4	4
Repetition Factor: r1	1	2
Number of Coded Signal Bits: m	8	16

3.6.4.1.1 (8,4) Hamming Encoding

Refer to Section 3.4.4.1.1.

3.6.4.1.2 Small Scrambling

Refer to Section 3.4.4.1.2.

3.6.4.2 Modulation for Signal

Figure 3.74 illustrates the pilot block S9 modulated by encoded signal bits for CSCH. Encoded signal bits of $N/2$ -bit are multiplexed into the pilot block S9 of N -symbol. When the n -th encoded signal bit $c(n)$ ($n=1,2,\dots,N/2$) is 0, the pilot symbol $P(n)$ is sent as it is, while the pilot symbol $P(N/2+n)$ is rotated by $\pi/2$ [rad]. When the n -th encoded signal bit $c(n)$ ($n=1,2,\dots,N/2$) is 1, the pilot symbol $P(N/2+n)$ is sent as it is, while the pilot symbol $P(n)$ is rotated by $\pi/2$ [rad]. This is equivalent to frequency-multiplexing BPSK symbols modulated by encoded signal bits and pilot symbols, in which each BPSK symbol is rotated by the angle of corresponding pilot symbol.

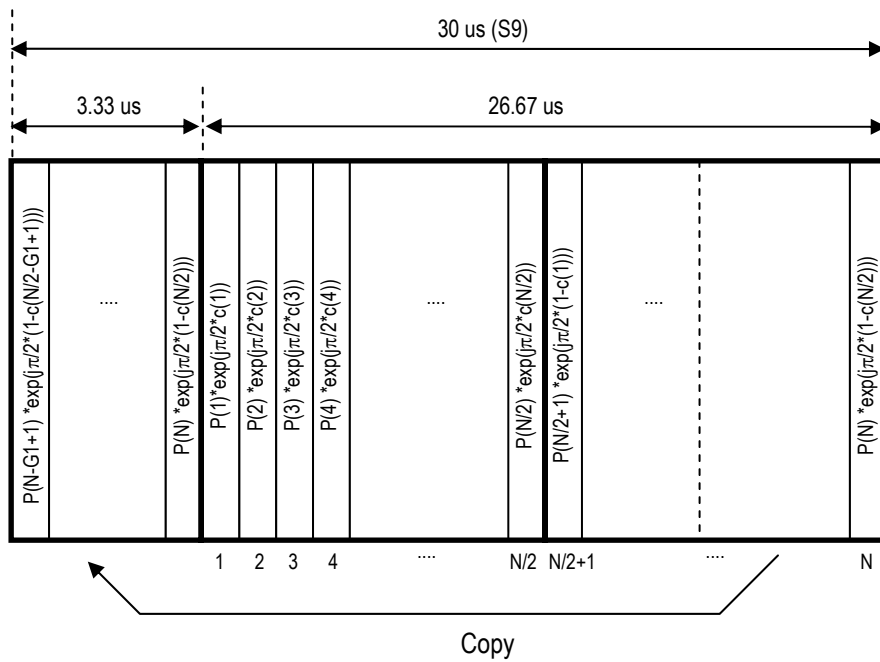

Figure 3.74 Pilot Block with Signaling Bits for CSCH

3.6.5 TCCH for UL SC

3.6.5.1 TCCH Format

TCCH is used mainly for transmission timing adjustment and for initial access to BS. Figure 3.75 shows the TCCH format. TCCH is composed of 3 consecutive SC blocks. TCCH symbols T(1) – T(16) are decided by the TCCH core-sequence number as explained in Section 3.6.5.2.

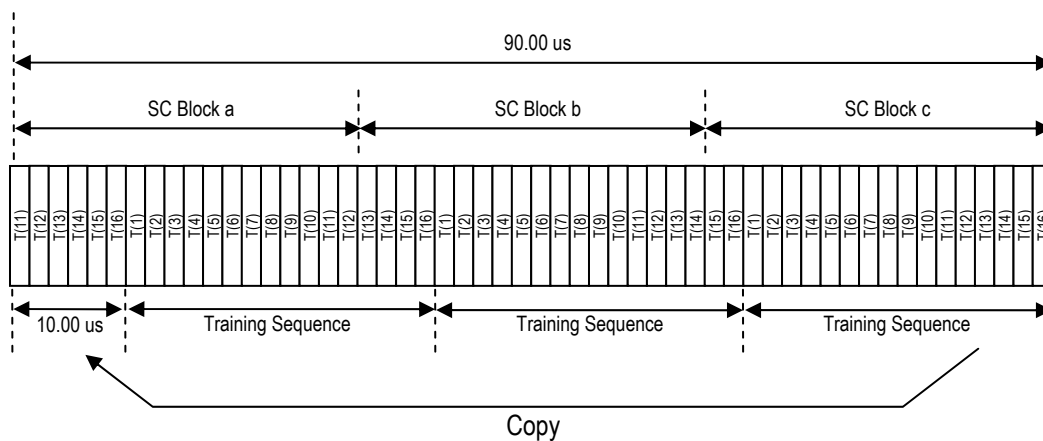

Figure 3.75 TCCH Block Structure

3.6.5.2 TCCH Sequence and TCCH Sub-slot

TCCH core-sequence number is described in Appendix D.2. TCCH sub-slots number is described in Section 3.6.6.1.2. The application patterns of TCCH core-sequence number and TCCH sub-slot number are described in Chapter 5.

3.6.6 SC Burst Structure for UL SC

SC burst is composed of training block, pilot block, data block and guard time.

3.6.6.1 CCH for UL SC

3.6.6.1.1 SC Burst Structure for CCCH

Figure 3.76 illustrates the SC burst structure for CCCH. Symbols in GI are not counted in the table. Table 3.33 summarizes the composition of CCCH. The number of CRC units is always 1 in CCCH.

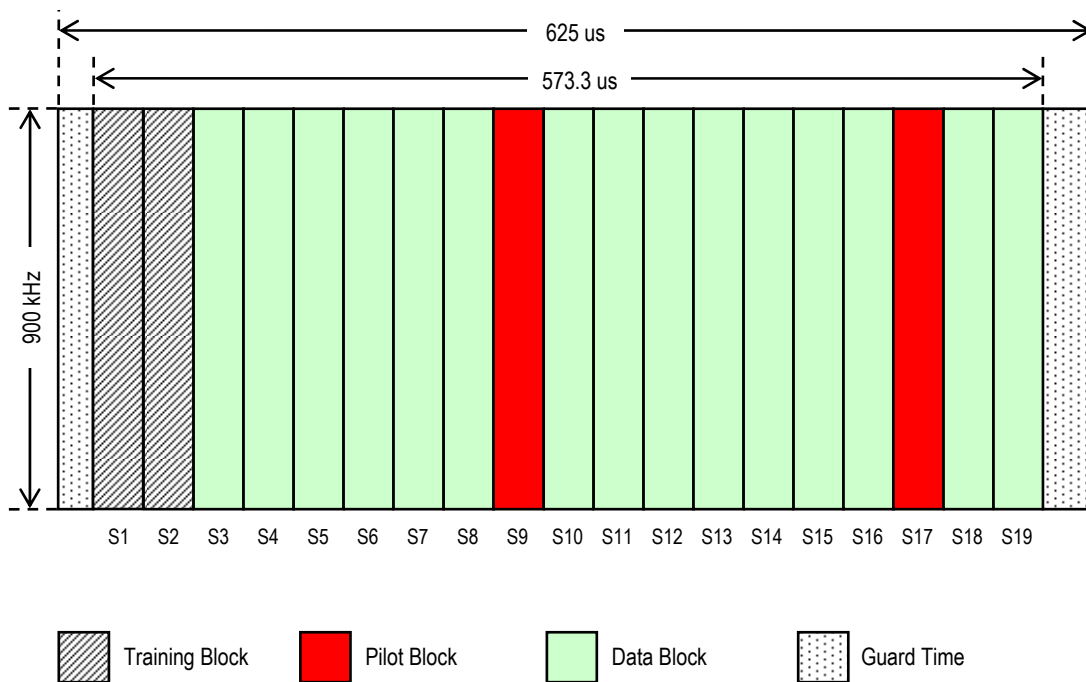

Figure 3.76 SC Burst Structure for CCCH

Table 3.33 Composition of CCCH

	w/o Virtual GI Extension	with Virtual GI Extension
Symbol Name	Number of Symbols	Number of Symbols
Data Symbol	240	230
Distinct Data Symbol	240	206
Training Symbol	32	34
Pilot Symbol	32	40
Total	304	304

3.6.6.1.2 SC Burst Structure for TCCH

Figure 3.77 describes the SC burst format for TCCH for UL SC. Within a slot time, there are four sub-slots, each of which is composed of three SC blocks. They are {S3, S4, S5}, {S7, S8, S9}, {S11, S12, S13} and {S15, S16, S17}. TCCH block defined in Section 3.6.5 is sent in one of the four sub-slots. Table 3.34 summarizes the composition of TCCH. Symbols in GI are not counted in the table.

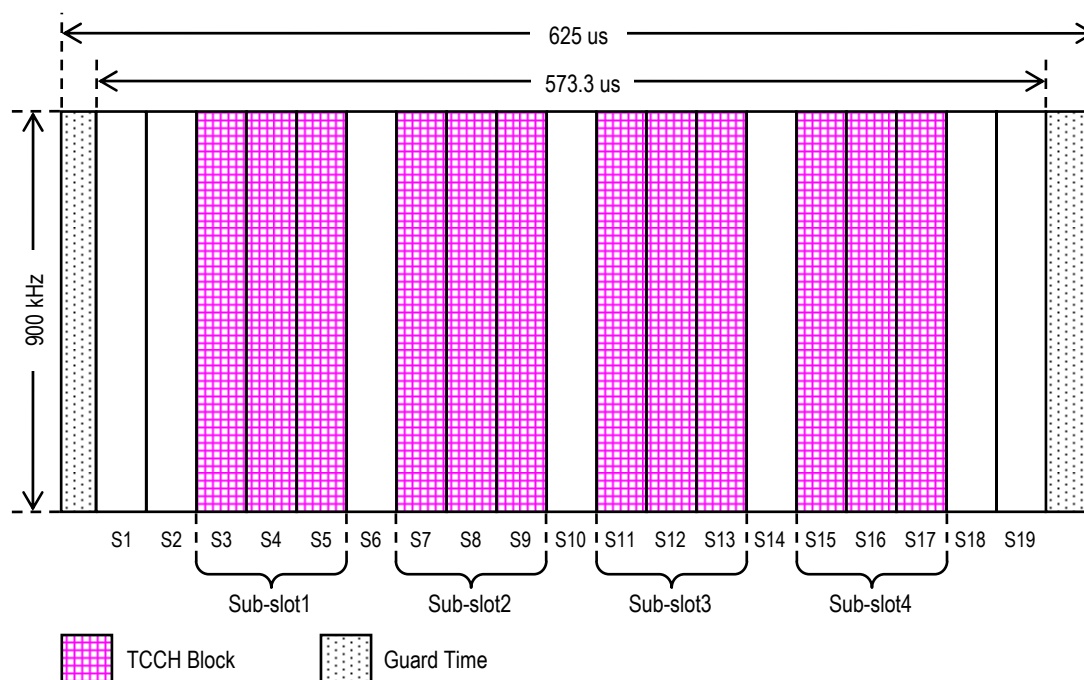

Figure 3.77 SC Burst Structure for TCCH

Table 3.34 Composition of TCCH

Symbol Name	Number of Symbols
TCCH Symbol	48*4 sub-slots

3.6.6.2 ICH for UL SC

3.6.6.2.1 SC Burst Structure for ANCH

Figure 3.78 describes a SC burst format for ANCH. Table 3.35 summarizes the composition of ANCH. Symbols in GI are not counted in the table. The number of CRC units is always 1 in ANCH.

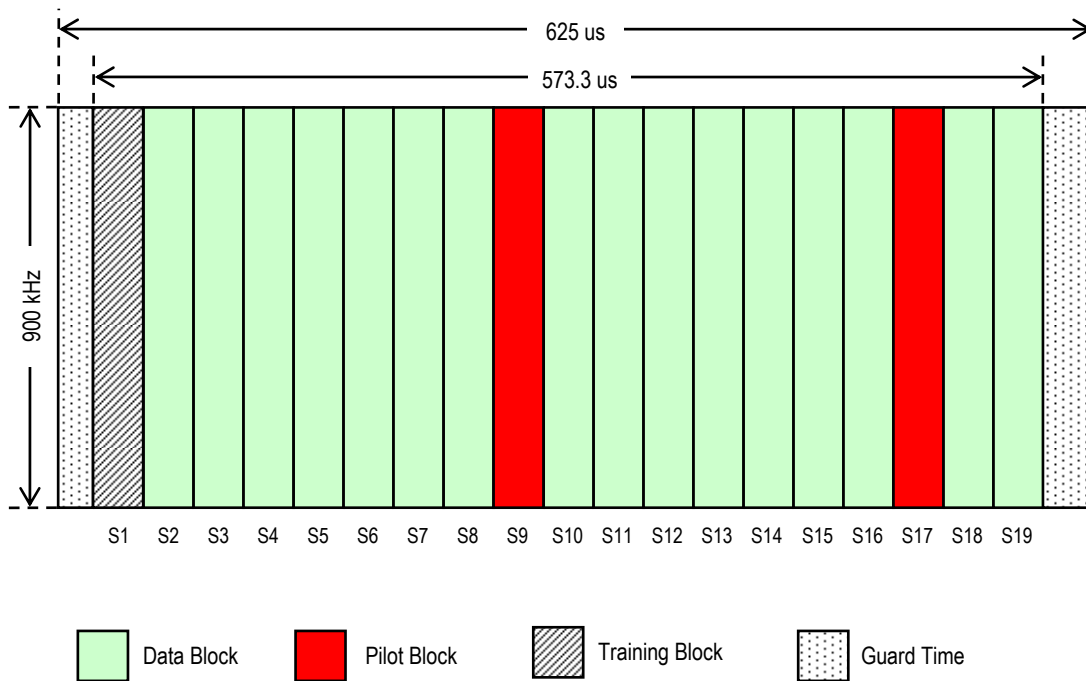

Figure 3.78 SC Burst Structure for ANCH

Table 3.35 Composition of ANCH

	w/o Virtual GI Extension	with Virtual GI Extension
Symbol Name	Number of Symbols	Number of Symbols
Data Symbol	256	246
Distinct Data Symbol	256	220
Training Symbol	16	18
Pilot Symbol	32	40
Total	304	304

3.6.6.2.2 SC Burst Structure for EXCH

Figure 3.79 illustrates a SC burst format for EXCH. Table 3.36 and Table 3.37 summarize the composition of EXCH for different symbol rates. Table 3.38 summarizes the composition of CRC unit in EXCH. Symbols in GI are not counted in these tables.

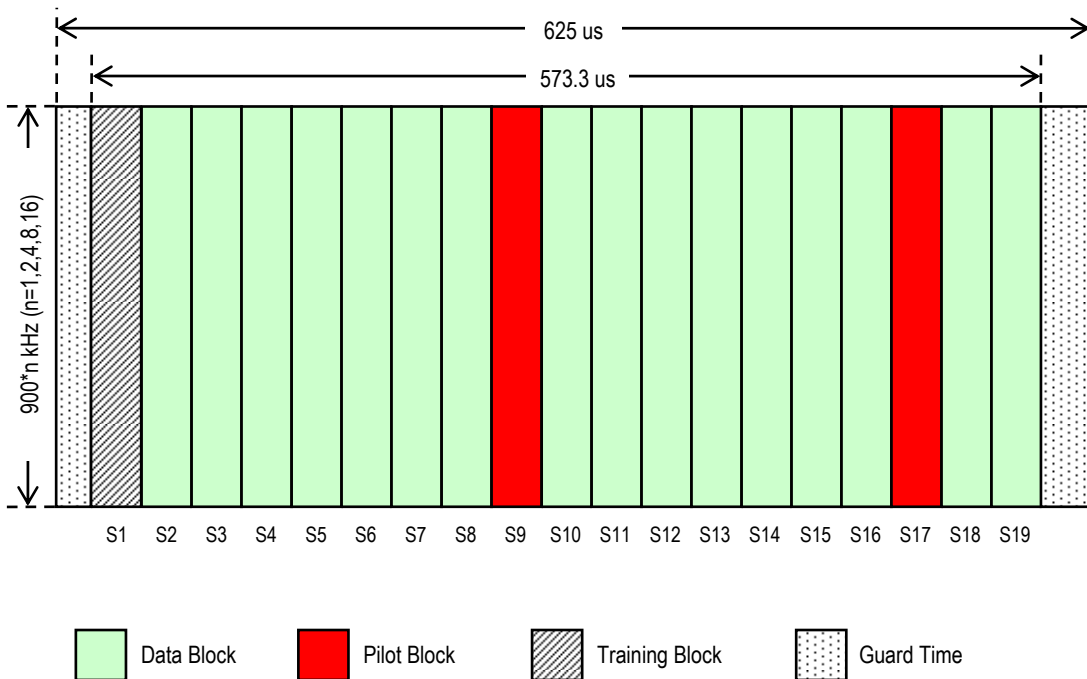

Figure 3.79 SC Burst Structure for EXCH

Table 3.36 Composition of EXCH (0.6 Msps)

	w/o Virtual GI Extension	with Virtual GI Extension
Symbol Name	Number of Symbols	Number of Symbols
Data Symbol	256	246
Distinct Data Symbol	256	220
Training Symbol	16	18
Pilot Symbol	32	40
Total	304	304

Table 3.37 Composition of EXCH (1.2 Msps)

	w/o Virtual GI Extension	with Virtual GI Extension
Symbol Name	Number of Symbols	Number of Symbols
Data Symbol	512	502
Distinct Data Symbol	512	476
Training Symbol	32	34
Pilot Symbol	64	72
Total	608	608

Table 3.38 CRC Unit for EXCH

Parameter		Type1	Type2
Symbol Rate [Msps]		0.6	1.2
Number of CRC Units		1	1
Number of Data Symbols per CRC Unit	w/o Virtual GI Extension	256	512
	with Virtual GI Extension	250	506
Number of Distinct Data Symbols per CRC Unit	w/o Virtual GI Extension	256	512
	with Virtual GI Extension	220	476

3.6.6.2.3 SC Burst Structure for CSCH

Figure 3.80 describes a SC burst format for CSCH. Table 3.39 and Table 3.40 summarize the composition of CSCH for different symbol rates. Table 3.41 summarizes the composition of CRC unit in CSCH. Symbols in GI are not counted in these tables. Note that EXCH and CSCH have the same compositions except for S9.

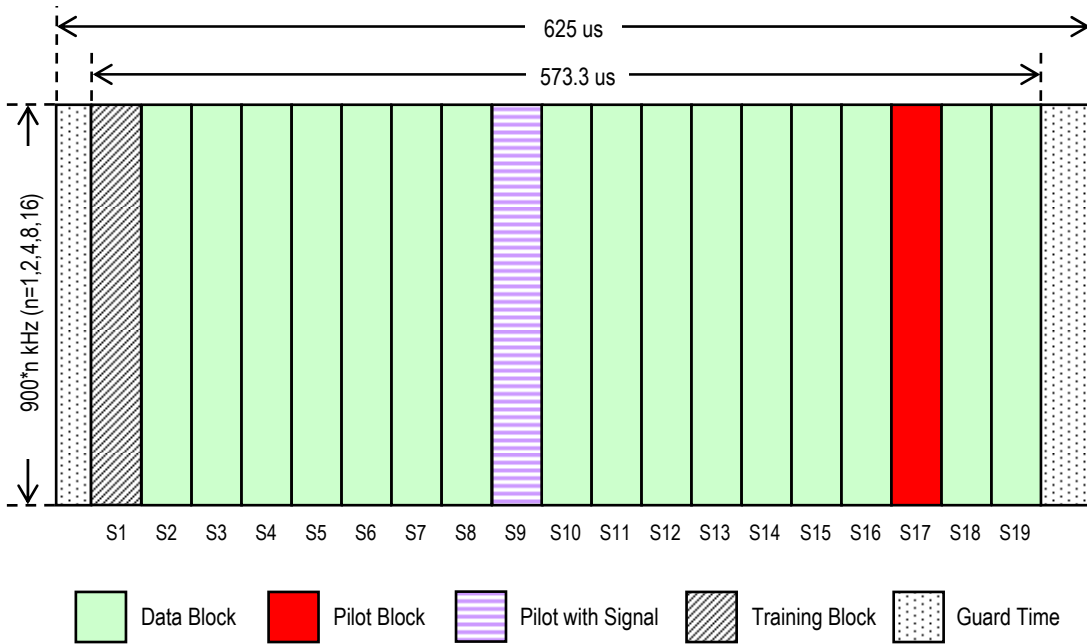

Figure 3.80 SC Burst Structure for CSCH

Table 3.39 Composition of CSCH (0.6 Msps)

	w/o Virtual GI Extension	with virtual GI Extension
Symbol Name	Number of Symbols	Number of Symbols
Data Symbol	256	246
Distinct Data Symbol	256	220
Training Symbol	16	18
Pilot Symbol	32	40
Coded Signal Bit	8	8
Total	304	304

(*) No encoded signal bit is counted in total.

Table 3.40 Composition of CSCH (1.2 Msps)

	w/o virtual GI Extension	with virtual GI Extension
Symbol Name	Number of Symbols	Number of Symbols
Data Symbol	512	502
Distinct Data Symbol	512	476
Training Symbol	32	34
Pilot Symbol	64	72
Coded Signal Bit	16	16
Total	608	608

(*) No encoded signal bit is counted in total.

Table 3.41 CRC Unit for CSCH

Parameter		Type1	Type2
Symbol Rate [Msps]		0.6	1.2
Number of CRC Units		1	1
Number of Data Symbols per CRC Unit	w/o Virtual GI Extension	256	512
	with Virtual GI Extension	250	506
Number of Distinct Data Symbols per CRC Unit	w/o Virtual GI Extension	256	512
	with Virtual GI Extension	220	476

3.6.6.3 CRC Unit for UL SC

Table 3.42 summarizes the CRC unit size for each symbol rate and channel format. In this table, CRC unit size means the number of bits in one CRC unit. Hence, the actual number of input bits to the CRC attachment (CRC unit) is 22-bit less than these numbers. Refer to the definition of CRC unit in Section 3.6.1.

Table 3.42 CRC Unit Size for UL SC

Modulation	Total Coding Rate	Efficiency	Channel (*)	Symbol Rate [MSPS]	
				0.6	1.2
π/2-BPSK	1 / 2	0.5	CC	120	N/A
	1 / 2	0.5	A,E,CS	128	256
	2 / 3	0.67	E,CS	170	N/A
π/4-QPSK	1 / 2	1		256	512
	3 / 4	1.5		384	768
8PSK	2 / 3	2		512	1024
16QAM	1 / 2	2		512	1024
	3 / 4	3		768	1536
64QAM	4 / 6	4		1024	2048
	5 / 6	5		1280	2560
256QAM	6 / 8	6		1536	3072
	7 / 8	7		1792	3584

(*) CC: CCCH, A: ANCH, E: EXCH, CS: CSCH

3.6.6.4 Transmission Timing of SC Burst for UL SC

Transmission timing is controlled by the BS in ANCH as described in Chapter 4. Since the symbol rate of EXCH can be different from that of ANCH, relative transmission timing of SC burst should be changed according to the symbol rate and virtual GI extension size in order to minimize the inter-carrier interference at BS. Relative transmission timing of the target SC burst (EXCH) is calculated from the reference SC burst (ANCH) using the following equation.

$$\Delta t_s = 0.5(g_1 - vg_1 - 1)/r_1 - 0.5(g_2 - vg_2 - 1)/r_2.$$

- r1: Symbol rate of the reference SC burst
- g1: GI size of the reference SC burst
- vg1: Virtual GI size of the reference SC burst
- r2: Symbol rate of the target SC burst
- g2: GI size of the target SC burst
- vg2: Virtual GI size of the target SC burst

Table 3.43 to Table 3.44 show the relative transmission timing for different symbol rates with or without virtual GI extension respectively.

Table 3.43 Relative Transmission Timing of SC Burst

	Type1	Type2
Symbol Rate [MSPS]	0.6	1.2
GI Size [symbol]	2	4
Virtual GI Size [symbol]	0	0
Relative Timing [us]	0	-0.417

Table 3.44 Relative Transmission Timing of SC Burst with Virtual GI Extension

	Type1	Type2
Symbol Rate [MSPS]	0.6	1.2
GI size [symbol]	2	4
Virtual GI Size [symbol]	2	2
Relative Timing [us]	0	-1.25

Chapter 4 Individual Channel Specification

4.1 Overview

This chapter describes the service and operation requirements applied to radio transmission facilities for sPHS.

The concept of protocol structure is described in Chapter 2 based on the ALL-IP network. The detail of the PHY layer for physical specification including several definitions of physical frame requirements is described in Chapter 3.

4.1.1 Usage of PRU

sPHS carries out control on information transmission necessary for call connection by making use of common channel (CCH). sPHS also carries out control on information to individual user and on user traffic transmission by making use of individual channel (ICH).

Figure 4.1 shows the access units of the entire channel bandwidth. Time duration of the TDMA frame is 5 ms and it is divided into 2.5 ms on UL and 2.5 ms on DL. Each TDMA frame is divided into four slots on UL and four slots on DL on the time axis. Effective channel bandwidth is divided into 900 kHz each to obtain FDMA slots. One unit, covering area of 625 us x 900 kHz, is defined as one physical resource unit (PRU).

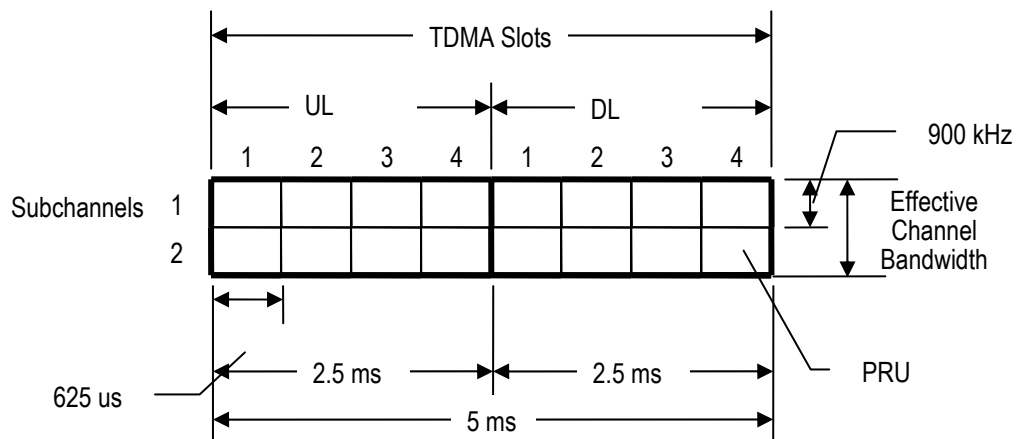

Figure 4.1 OFDMA/SC-FDMA/TDMA-TDD

Generally, a certain fixed subchannel will be fit into common channel (CCH). Other FDMA slots will be used as individual channel (ICH).

4.1.1.1 Common Channel (CCH)

One PRU pair out of eight PRUs is used for a BS as CCH. One is in DL and the other is in UL.

4.1.1.2 Individual Channel (ICH)

ICH consists of an anchor channel (ANCH) which is used as a dedicated control channel, extra channels (EXCH) which are mainly used for the user data transmission, and circuit switching channels (CSCH) which are used for the user data and control transmission.

Figure 4.2 shows an example to use ICH. The figure shows that four users: User 1, User 2, User 3, and User 4 are connected to a BS. A1 is ANCH for User 1. E1 is EXCH for User 1. A2 is ANCH for User 2. E2 and E3 are EXCH for User 2. C3 is CSCH for User 3. C4 is CSCH for User 4. The figure shows that User 1 is using one EXCH, User 2 is using two EXCHs, and User 3 and User 4 are using one CSCH each.

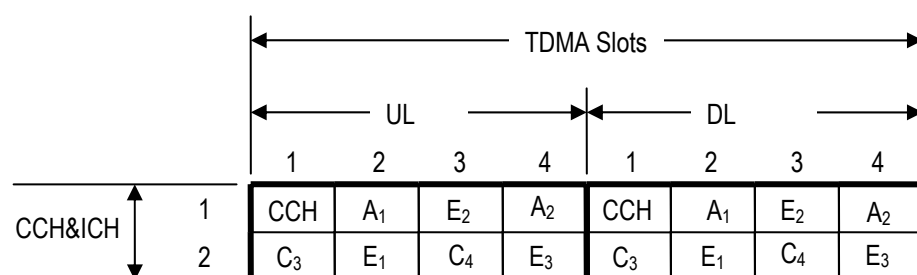

Figure 4.2 Example of ICH Usage

Every active user is allocated with one PRU as ANCH or CSCH, and it may also be allocated with either one or more PRU(s) as EXCH. The ANCH and CSCH for every active user is allocated with the same PRU on every TDMA frame. However, the EXCH PRU allocation will be changed dynamically in every TDMA frame. PRUs of ICH are allocated symmetrically. Symmetrical PRU stands for a PRU of same TDMA slot, same PRU on both UL and DL. As for ANCH, CSCH and EXCH, the allocation control is performed in each PRU.

4.1.1.2.1 PRU Numbering

Figure 4.3 shows the PRU numbering rule. All the given system bands are numbered and are defined as PRU number. MS is given a part of effective channel bandwidth, and the PRU number in the given band is called logical PRU number. First PRU means the PRU of the earliest timing and lowest frequency. PRU number is counted in the direction of a time-axis by order.

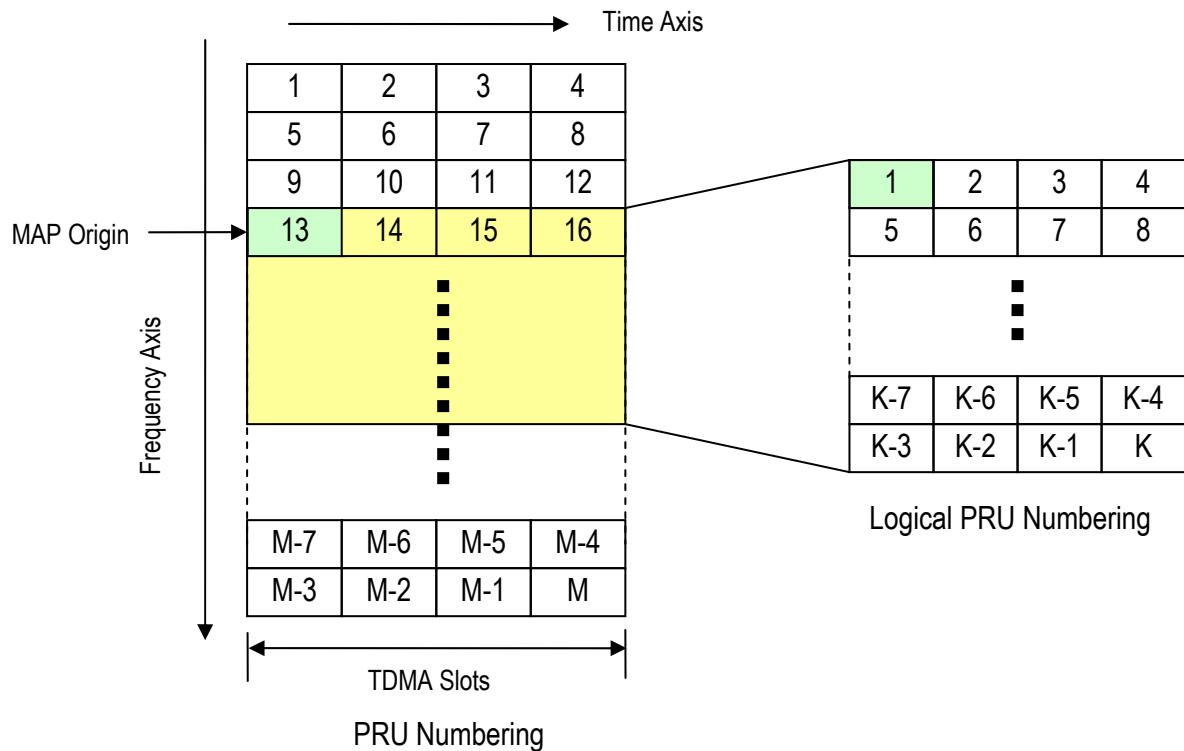

Figure 4.3 Rule of PRU Numbering

4.1.2 QoS Class (Access Mode)

sPHS provides multiple QoS class for user traffic transmission.

4.1.2.1 Fast Access Channel Based on Map (FM-Mode)

Four services of QoS class except PLC (Private Line Class) service are provided using a communication control method called FM-Mode. In FM-Mode, BS assigns an ANCH as control channel to MS. BS also assigns EXCH dynamically as traffic channel for data communication. BS assigns EXCH using information elements in ANCH which changes according to the traffic, radio conditions etc. In FM-Mode, control information is transmitted by stealing data channel or control channel as required.

4.1.2.2 High Quality Channel Based on Carrier Sensing (QS-Mode)

PLC service of QoS class is provided using a communication control method called QS-Mode. QS-Mode is achieved by making use of a channel called CSCH. BS makes sure that the frequency band of CSCH resembles circuit switching connection. In addition, CSCH is a high quality PRU as the result of the carrier sensing on UL and DL are both positive on assigning PRU.

In QS-Mode, BS transmits control information instead of data to MS as required. BS uses control channel at CSCH transmission of QS-Mode, which accompanies respective data PRU at all

times.

4.1.3 sPHS Protocol Outline

4.1.3.1 Frame Structure

The frame of each layer consists of a header and one data unit or more. Table 4.1 shows the compositions of the PHY and MAC layer frame.

Table 4.1 Name of Frame Composition

Composition	PHY Layer	MAC Layer
Frame	PHY Frame	MAC Frame
Header	PHY Header	MAC Header
Data Unit	PHY Data Unit	MAC Data Unit

Figure 4.4 shows the composition of the PHY and MAC layer frames. In each frame, a header is put at top of the frame, and is followed by one or more data units. Figure 4.4 shows the order of bits and octets. Transmission and reception are carried out from the upper bit. First transmission and reception begin from the Octet 1.

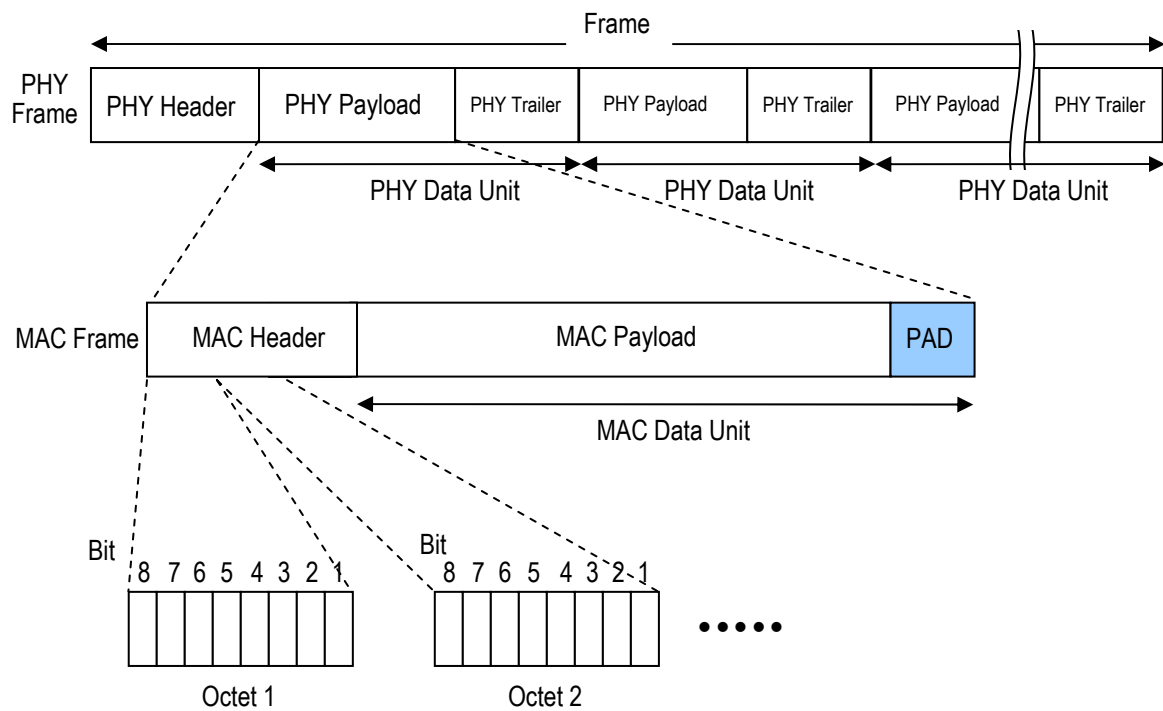

Figure 4.4 General Frame Structure

4.1.3.2 Protocol Structure

The protocol structure is shown in Figure 4.5. Basically, protocol layer between MS and BS consists of a PHY and MAC layer. The PHY layer controls physical wireless line between MS and BS.

MAC layer controls link establishment, channel assignment, channel quality maintenance etc. The upper network layer is based on IP protocols. This document describes the specification of PHY and MAC layer between MS and BS.

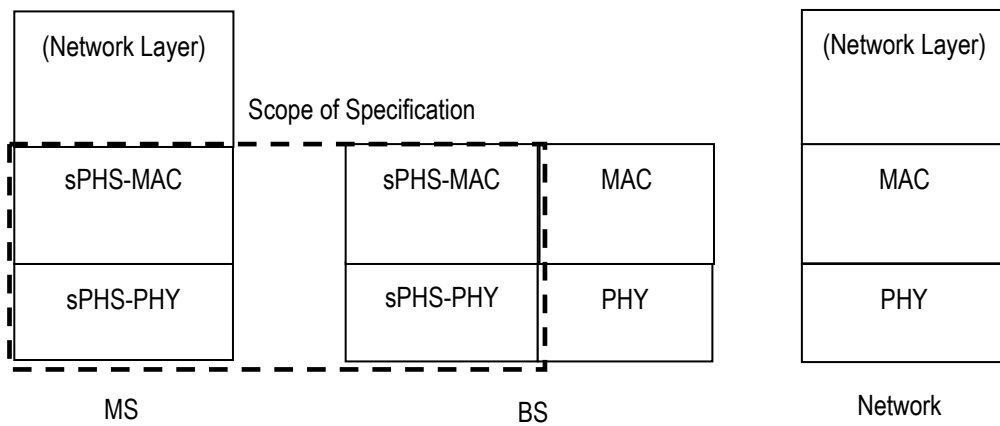

Figure 4.5 Protocol Stack for sPHS

Figure 4.6 shows the protocol structure for MAC control layer. The control messages are transferred on the MAC-CNT (MAC control) layer of the sPHS-MAC layer. These messages are categorized functionally as mobility Management (MM), and radio frequency transmission management (RT). In this specification, the message format on MAC layer level is defined in Section 4.4.4.

Control messages processed between MS and network are transparently sent though on BS MAC layer.

The packet data is transparently transferred to between MS and network.

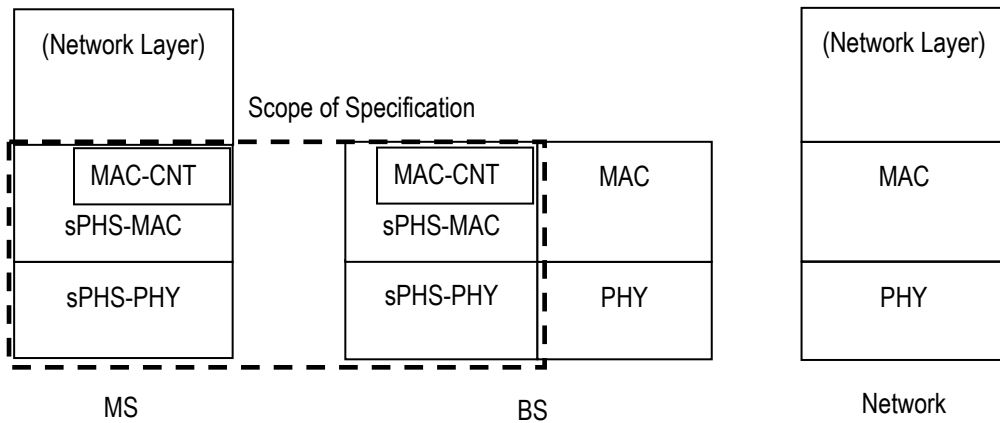

Figure 4.6 Protocol Stack for sPHS (MAC Control)

4.2 Functional Channel

The channel classified according to the information it carries is defined as a functional channel.

4.2.1 Channel Composition

Figure 4.7 shows channel hierarchy composition. ICH contains CSCH, ANCH and EXCH. ICH is classified into six functional channels, which are ICCH, ECCH, EDCH, CDCH, TCH and ACCH.

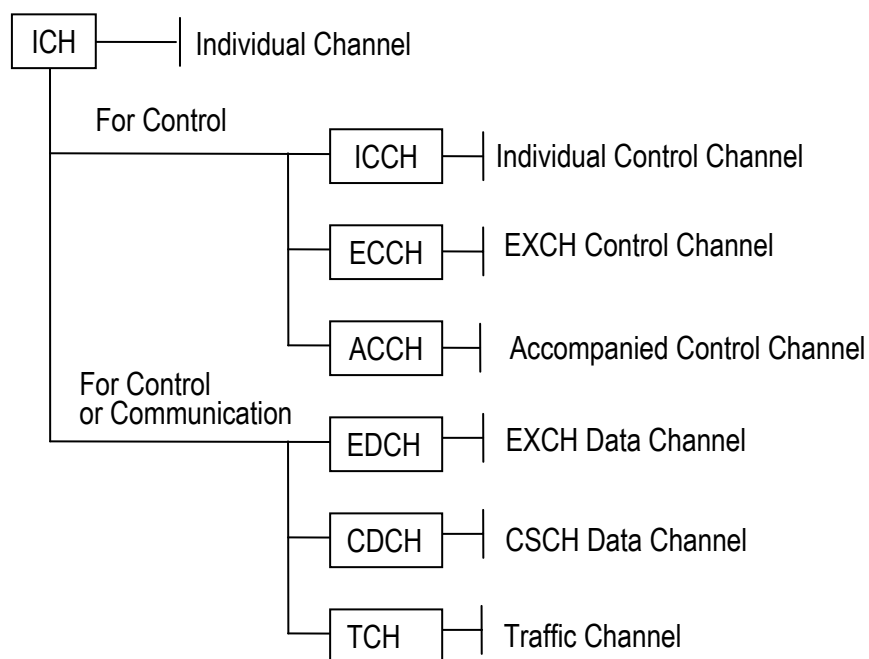

Figure 4.7 Composition of Channels

The correspondence between the functional channels and protocol phase as well as PRU is shown in Figure 4.8.

PRU		Protocol Phase	
		Access Establishment Phase	Access Phase
ICH	ANCH	ICCH	ECCH ICCH
	EXCH		EDCH
	CSCH		CDCH ACCH TCH

Figure 4.8 PRU, Protocol Phase and Functional Channel Correspondence

4.2.1.1 Individual Control Channel (ICCH)

ICCH is an UL/DL bidirectional control channel which is put into allocated PRU as ANCH. It transmits control information.

ICCH is used with the communication method in both FM-Mode and QS-Mode. And ICCH is used at not only access establishment phase but also access phase.

4.2.1.2 EXCH Control Channel (ECCH)

ECCH is an UL/DL bidirectional control channel which is put into allocated PRU as ANCH. It contains some data that can be applied to control channel allocation for EXCH, MCS, transmission power and timing etc.

ECCH is used in FM-Mode at access phase. ECCH is logically connected with EDCH(s). It operates like the header of the connected format.

The MCS of ECCH is a fixed rate of BPSK-1/2 for OFDM and $\pi/2$ -BPSK-1/2 for SC.

4.2.1.3 EXCH Data Channel (EDCH)

EDCH is an UL/DL bidirectional channel which is put into allocated PRU as EXCH. It transmits user traffic data.

EDCH is used in access phase.

EDCH can change a modulation method in accordance with the state of radio wave fundamentally, and can execute communication function.

EDCH is used in FM-Mode and it is put into allocated PRU as EXCH. One or more EDCHs are connected to one ECCH logically to form one format. Then, EDCH operates like the data payload of the connected format.

4.2.1.4 CSCH Data Channel (CDCH)

CDCH is an UL/DL bidirectional channel which is put into allocated PRU as CSCH. It transmits user traffic data.

CDCH is used in access phase.

CDCH can change a modulation method in accordance with the state of radio wave fundamentally, and can execute communication function.

It is replaced in order to transmit control information constantly.

CDCH is used for the data communications in QS-Mode. It is put into allocated PRU as CSCH.

4.2.1.5 Traffic Channel (TCH)

TCH is an UL/DL bidirectional channel which is put into allocated PRU as CSCH.

TCH is used in QS-Mode at access phase to transmit bearer constant rate data fundamentally.

The MCS of TCH is pre-defined and retransmission control is not performed. TCH is transmitted by the same PRU as ACCH which contains control information.

4.2.1.6 Accompanied Control Channel (ACCH)

ACCH is UL/DL bidirectional control channel which accompanies TCH in allocated PRU as CSCH. It transmits control information.

ACCH is used by access phase in QS-Mode. Like TCH, the MCS of ACCH is the same as the payload and retransmission control is not performed.

4.3 PHY Layer Structure and Frame Format

4.3.1 PHY Frame Structure

There are three PHY frame types including ANCH, EXCH, and CSCH.

ICCH, ECCH, EDCH, CDCH, TCH and ACCH are functional channels put into PHY frame.

:

4.3.1.1 ANCH/ICCH

Figure 4.9 shows ANCH frame structure which contains ICCH. The ANCH contains PHY header, ICCH, CRC and TAIL bits.

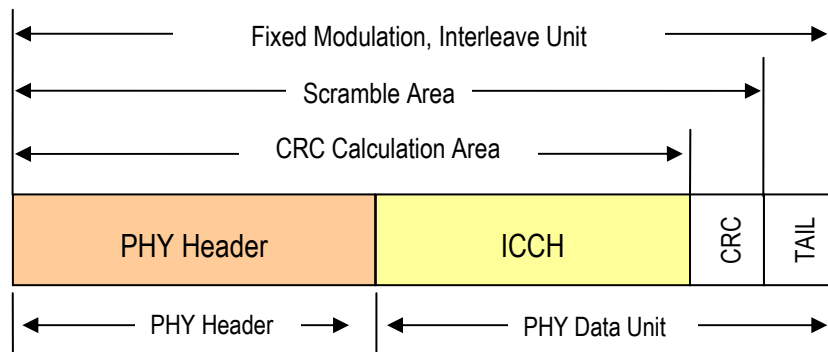

Figure 4.9 PHY Frame Format of ANCH/ICCH

4.3.1.2 ANCH/ECCH

Figure 4.10 shows the ANCH frame structure which contains ECCH. The ANCH contains PHY header, ECCH, CRC and TAIL bits.

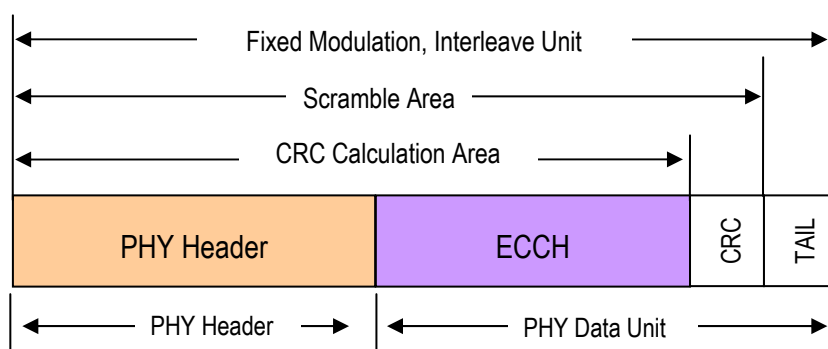

Figure 4.10 PHY Frame Format of ANCH/ECCH

4.3.1.3 EXCH/EDCH

Figure 4.11 shows EXCH/EDCH frame structure which consists of one or more EXCH(s). The EXCH contains EDCH, CRC and TAIL bits.

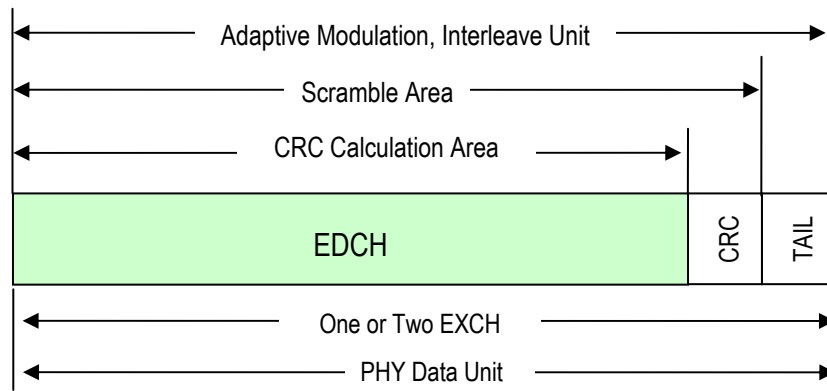

Figure 4.11 PHY Frame Format of EXCH/EDCH

4.3.1.3.1 PRU Combining

The PHY frame is made up of one or more PRUs. UL and DL PHY frame format is defined in the following sections. PHY frame is created by combining the payloads of PRU(s) specified by the MAP field. (Refer to Section 4.3.6.7 for MAP field). Figure 4.12 shows order of constructing PHY frame. PRUs specified with MAP are connected in the direction of frequency.

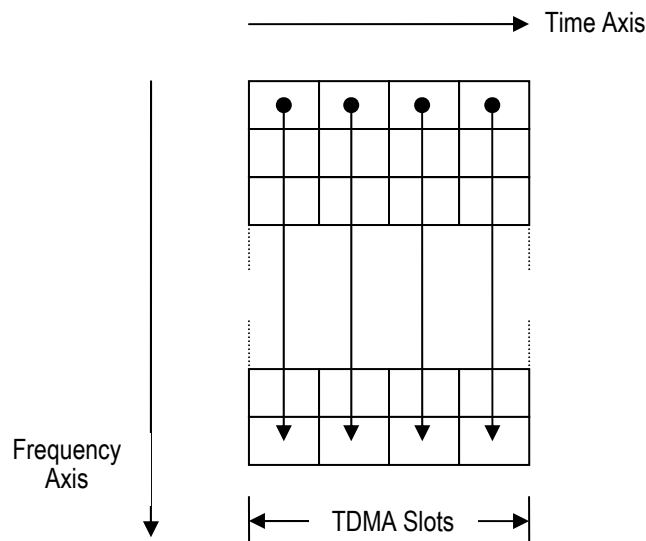

Figure 4.12 Order of Logical PRU Combining

4.3.1.4 CSCH/TCH

Figure 4.13 shows CSCH frame structure. CSCH/TCH consists of a PHY header, ACCH, TCH, CRC and TAIL bits.

A part of PHY control is used as signal symbol with hamming code. (Refer to Section 3.4.4). The signal symbol is not included in the application range of CRC calculation.

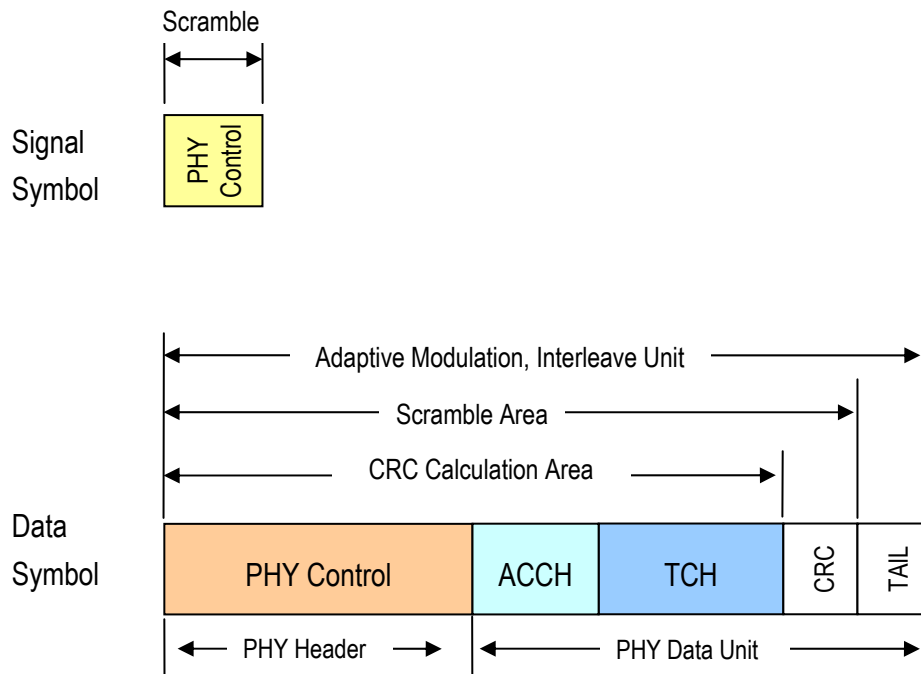

Figure 4.13 PHY Frame Format of CSCH/TCH

4.3.1.5 CSCH/CDCH

Figure 4.14 shows CSCH frame structure. CSCH/CDCH consists of a PHY header, CDCH, CRC and TAIL bits.

A part of PHY control is used as signal symbol with hamming code. (Refer to Section 3.4.4). The signal symbol is not included in the application range of CRC calculation.

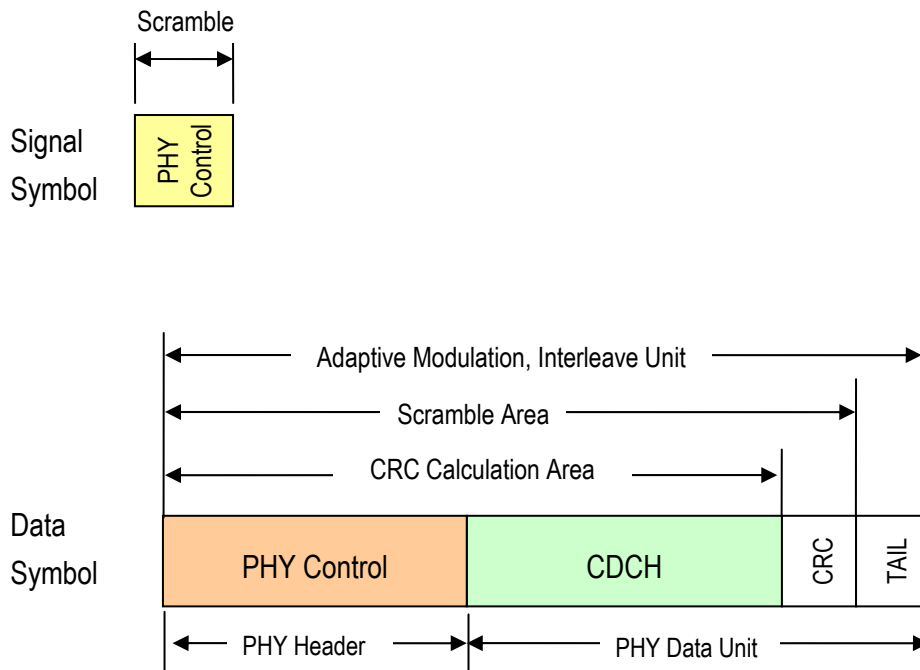

Figure 4.14 PHY Frame Format of CSCH/CDCH

4.3.2 Signal Symbol

4.3.2.1 Signal Symbol Structure

Figure 4.15 shows signal symbol structure. It consists of MI only. Refer to Section 4.3.6 for MI field.

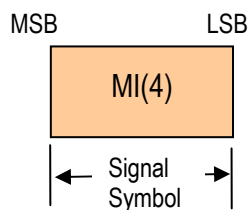

Figure 4.15 Signal Symbol Structure

4.3.3 PHY Header

4.3.3.1 PHY Header Structure

A PRU format, functional channel type, and the direction of a link determine the format of a PHY header.

4.3.3.1.1 ANCH/ECCH PHY Header Structure

Figure 4.16 shows ANCH/ECCH PHY header structure. It consists of only CI. Refer to Section 4.3.6 for CI field.

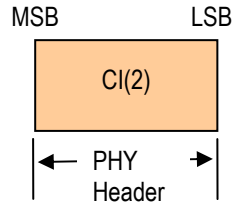

Figure 4.16 PHY Header Structure of ANCH/ECCH

4.3.3.1.2 ANCH/ICCH PHY Header Structure

Figure 4.17 shows ANCH/ICCH PHY header format. DL ANCH/ICCH PHY header format consists of CI, SD and APC. UL ANCH/ICCH PHY header format consists of CI and APC. Refer to Section 4.3.6 for each field.

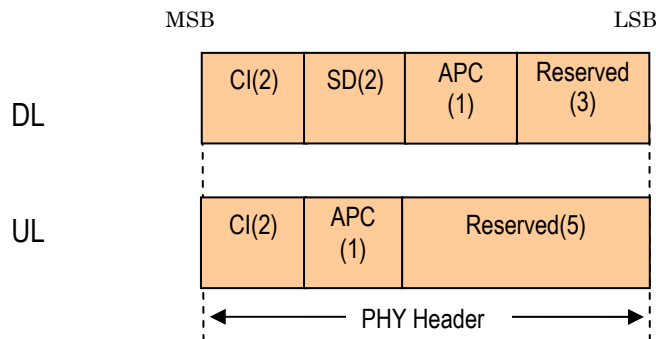

Figure 4.17 PHY Header Structure of ANCH/ICCH

4.3.3.1.3 CSCH/CDCH PHY Header Structure

Figure 4.18 shows the structure of UL/DL CSCH/CDCH PHY header. DL CSCH/CDCH PHY header contains CI, MR, SD, PC and ACK. UL CSCH/CDCH PHY header contains CI, MR, PC and ACK. Refer to Section 4.3.6 for each field.

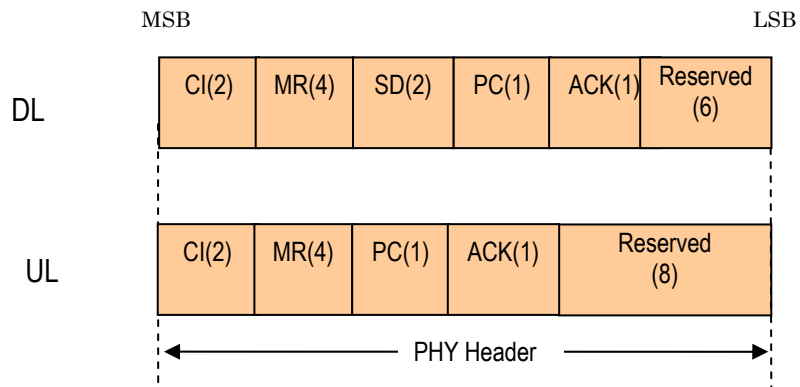

Figure 4.18 PHY Header Structure of CSCH/CDCH

4.3.3.1.4 CSCH/TCH PHY Header Structure

Figure 4.19 shows the structure of UL/DL PHY header of CSCH/TCH. CI, MR, SD, and PC are contained in DL PHY header. CI, MR and PC are contained in UL PHY header. Refer to Section 4.3.6 for each field.

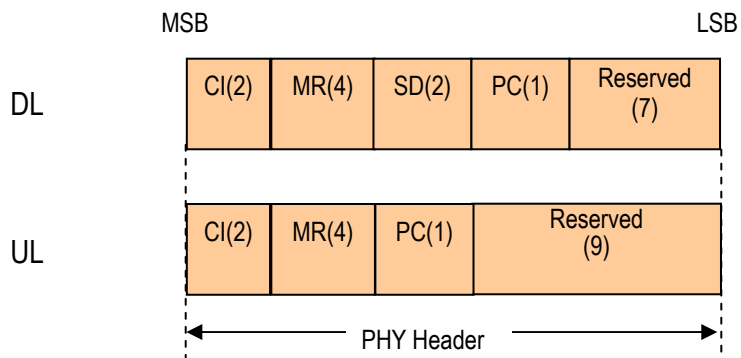

Figure 4.19 PHY Header Structure of CSCH/TCH

4.3.3.1.5 ECCH PHY Header Structure

Figure 4.20 shows the configuration of the ANCH/ECCH PHY header structure. Refer to Section 4.3.6 for each field.

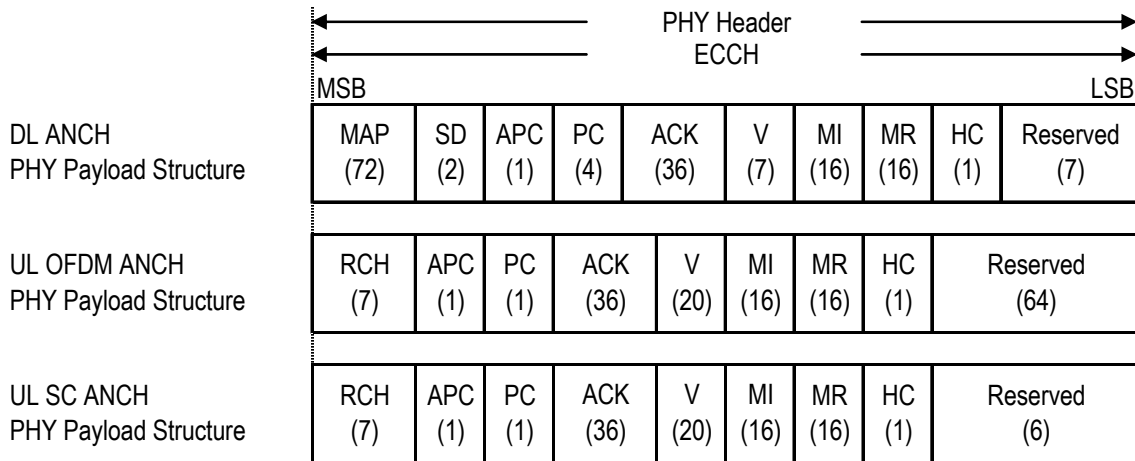

Figure 4.20 Configuration of ANCH

4.3.3.2 ECCH

ECCH is used as PHY header (Refer to Section 4.3.3.1.5).

4.3.3.2.1 CRC Error Happening on the ANCH

Table 4.2 shows the processing of MS when the CRC error happens on the DL ANCH.

MS cannot recognize the MAP field indicated by DL ANCH when it is an error. As a result, MS cannot transmit UL EXCH in the frame that the MAP cannot recognize. Then, MS sets V to 0 in UL ANCH of the frame, and it cannot recognize the ACK field indicated by DL ANCH when it is an error either. As a result, MS cannot recognize the receiving state of UL EXCH in a corresponding frame. In this case, MS will set HC to 1 in the UL ANCH, and will inform that HARQ is canceled to BS.

Furthermore, MS cannot recognize the DL EXCH assignment by DL ANCH when it is an error. As a result, MS sets all bits of ACK to 1 in the corresponding UL ANCH.

Table 4.2 Processing when CRC Error Happens in DL ANCH

Name	Processing
MAP	Act as no bandwidth is allocated.
ACK	It is impossible to identify whether ACK or NACK.
SD	Current transmission timing is maintained.
PC, APC	A current TX power is maintained.
V	It treats as 0.
HC	It is set HARQ cancel.(HC=1)
MI	Act as no bandwidth is allocated.
MR	Valid MR most recently received is used.

Table 4.3 shows the processing when the CRC error happens on the UL ANCH.

BS cannot recognize the ACK field indicated by UL ANCH when it is an error. Therefore, BS cannot recognize the receiving state of DL EXCH in a corresponding frame. In this case, BS will set HC to 1 in the DL ANCH of the timing which retransmits data, and will inform that HARQ is canceled to MS.

Additionally, BS cannot recognize the MI and V field indicated by UL ANCH when it is an error. AS a result, BS cannot receive UL EXCH in the frame. Then, BS sets all bits of ACK to 1 in the corresponding DL ANCH.

Table 4.3 Processing when Error Happens in UL ANCH

Name	Processing
RCH	Act as if no bandwidth assignment request has been sent.
ACK	If CRC error happens, it is impossible to identify whether it is.
PC , APC	A current TX power is maintained.
V	It treats as 0.
HC	It is set HARQ cancel.(HC=1)
MI	Act as no bandwidth is allocated.
MR	Valid MR most recently received is used.

4.3.4 PHY Payload

4.3.4.1.1 PHY Payload Structure

Figure 4.21 shows the configuration of PHY payload.

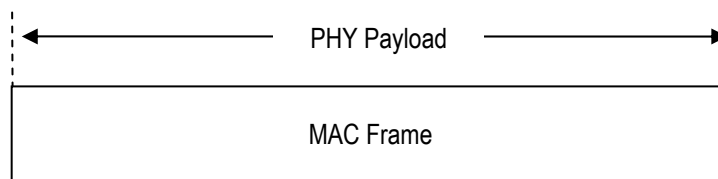

Figure 4.21 Configuration of PHY Payload

4.3.5 PHY Trailer

4.3.5.1 CRC

The PHY payload length and CRC length are changed flexibly according to the MCS. In this section, PHY payload length, and CRC length is defined according to the MCS and the PHY data unit.

CRC (Cyclic Redundancy Code) 16 is inserted. Section 4.3.1 shows the range of the CRC calculation.

4.3.5.2 TAIL

TAIL field is inserted so that the state of the shift register of the convolutional encoding module becomes empty. Assuming K is the constraint length of error correction, then TAIL bit length is K-1 bits. Number of TAIL bits is 6.

4.3.6 PHY Control Layer

This section explains each field in the PHY frame.

4.3.6.1 Channel Identifier (CI)

CI shows what kind of information has been transmitted by PRU.

4.3.6.1.1 CI of ANCH

It indicates the channel identifier of PHY payload in FM-Mode. Table 4.4 shows the values of the CI field.

Table 4.4 Value of CI Field

Bit		Channel Identifier of PHY Payload
2	1	
0	0	ANCH/ICCH
0	1	ANCH/ECCH
1	0	Reserved
1	1	Reserved

4.3.6.1.2 CI of CSCH

It indicates the channel identifier of PHY payload indicated in QS-Mode. Table 4.5 shows the value of the CI field.

Table 4.5 Value of CI Field

Bit		Channel Identifier of PHY Payload
2	1	
0	0	CSCH/TCH
0	1	CSCH/CDCH
1	0	Reserved
1	1	Reserved

4.3.6.2 Shift Direction (SD)

SD controls the UL transmission timing of the MS. Table 4.6 specifies the value of the SD field and its corresponding processing. (Refer to Section 9.4.2).

Table 4.6 Value of SD Field

Bit		Operation of MS
2	1	
0	0	Stay
0	1	One Step Backward
1	0	Two Steps Forward
1	1	One Step Forward

(Note) Unit = $30 / (512 + 64)$ us

4.3.6.3 ANCH Power Control (APC)

APC controls the transmission power of the ANCH of the MS so that signals from different MSs will be received by BS at the same level. Because once UL radio wave which has different reception level is detected, BS will control the UL transmission power either by increasing or decreasing APC field according to the UL reception level for each MS. (Refer to Section 9.4.1).

Table 4.7 Value of APC Field

APC Value	Operation of MS
0	Decrease transmission power.
1	Increase transmission power.

(Note) Unit = 1 dB

4.3.6.4 Power Control (PC)

PC controls the transmission power of the EXCH or CSCH of the MS so that signals from different MSs will be received by BS at the same level. Because once UL radio wave which has different reception level is detected, BS will control the UL transmission power either by

increasing or decreasing PC field according to the UL reception level for each MS. (Refer to Section 9.4.1).

Table 4.8 Value of PC Field

PC Value	Operation of MS
0	Decrease transmission power.
1	Increase transmission power.

(Note) Unit = 1 dB

ECCH contains power control fields for each slot, and controls each slot separately. Table 4.9 shows the PC field of each slot.

Table 4.9 PC Field Composition

	First Bit			Last Bit
Controlled Slot	Slot 1	Slot 2	Slot 3	Slot 4

4.3.6.5 MCS Indicator (MI) and MCS Request (MR)

The MI field indicates the MCS of the adaptive modulation part in the DL PHY frame. The MR field indicates the UL MCS requested by the MS according to the result of the UL signal monitoring. Table 4.10 and Table 4.11 show the correspondence between each field and the MCS.

Table 4.10 MCSs for OFDM

Bit				Modulation Class	Puncturing Rate	Efficiency
4	3	2	1			
0	0	0	0	BPSK	1	0.5
0	0	0	1		3/4	0.67
0	0	1	0	QPSK	1	1
0	0	1	1		4/6	1.5
0	1	0	0	Reserved	-	-
0	1	0	1	16QAM	1	2
0	1	1	0		4/6	3
0	1	1	1	64QAM	3/4	4
1	0	0	0		6/10	5
1	0	0	1	256QAM	4/6	6

Bit				Modulation Class	Puncturing Rate	Efficiency
4	3	2	1			
1	0	1	0		8/14	7

Table 4.11 MCSs for SC

Bit				Modulation Class	Puncturing Rate	Efficiency
4	3	2	1			
0	0	0	0	$\pi/2$ -BPSK	1	0.5
0	0	0	1		3/4	0.67
0	0	1	0	$\pi/4$ -QPSK	1	1
0	0	1	1		4/6	1.5
0	1	0	0	8PSK	3/4	2
0	1	0	1	16QAM	1	2
0	1	1	0		4/6	3
0	1	1	1	64QAM	3/4	4
1	0	0	0		6/10	5
1	0	0	1	256QAM	4/6	6
1	0	1	0		8/14	7

4.3.6.5.1 MI and MR in ECCH

In ECCH MI and MR are specified for every slot. Figure 4.22 shows the structure of the MI/MR field in ECCH.

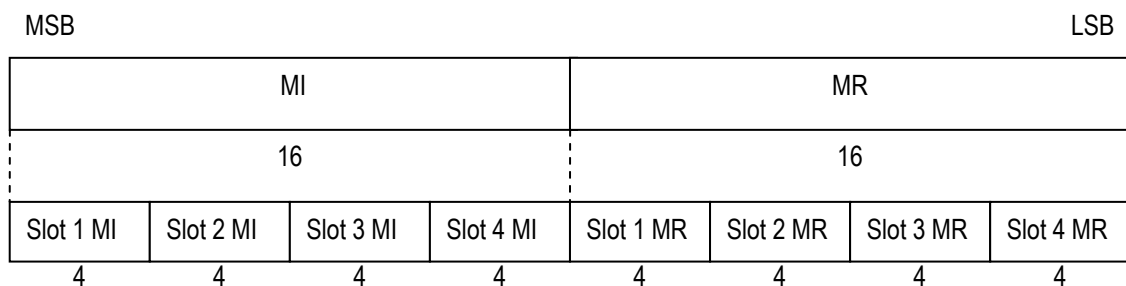

Figure 4.22 MI and MR Indication in ECCH

4.3.6.5.1.1 MI Indication Timing of DL

Figure 4.23 shows an example of MI indication timing. DL MI applies to the EXCH to which the MAP is in the same ANCH points. DL MI indicates MCS of DL EXCH of one frame after in case of (a) timing 1 (Refer to Section 6.4.1.1.1), and indicates MCS of DL EXCH two frames after in the case of (b) timing 2.

The response timing between MS and BS is negotiated in access establishment phase.

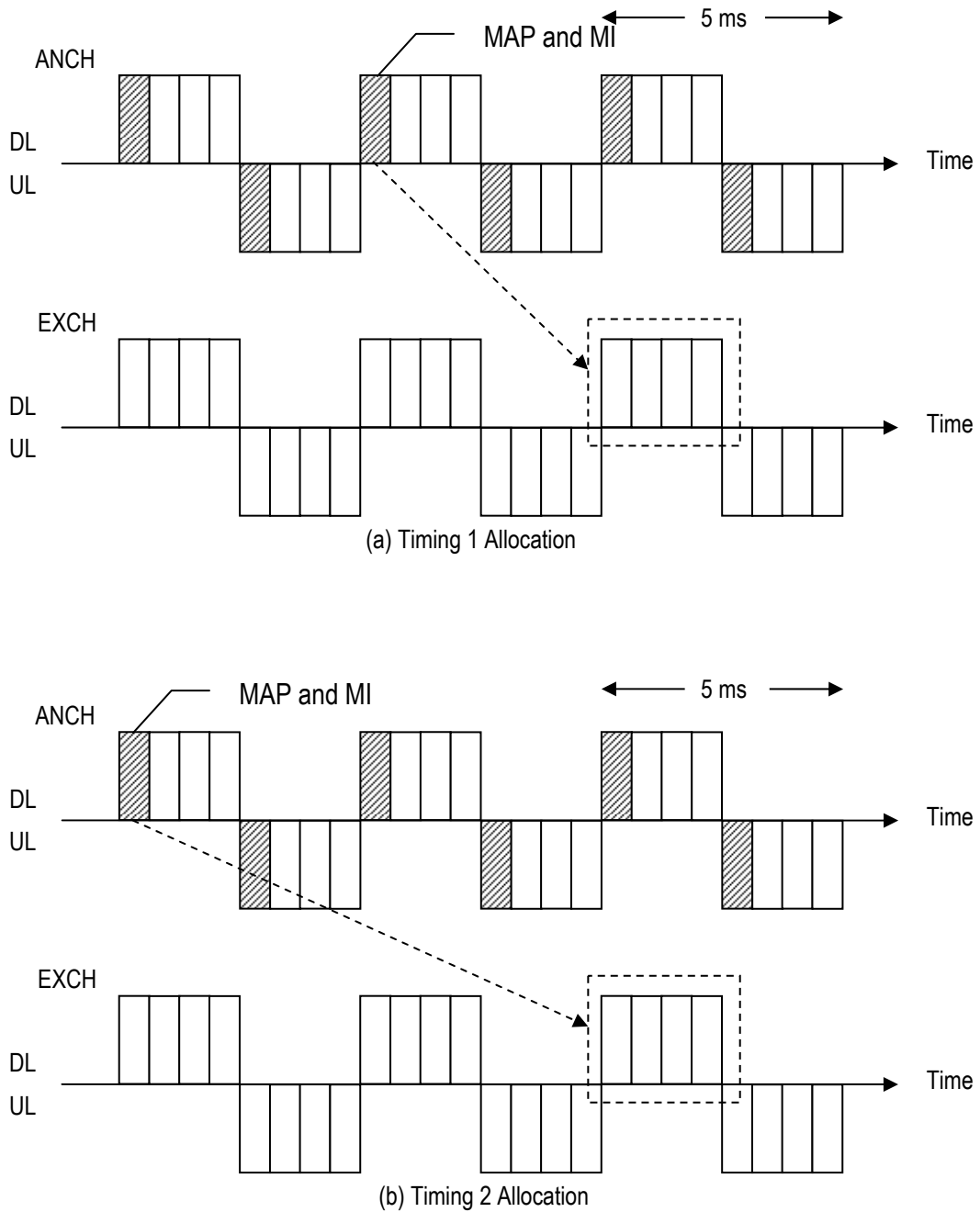
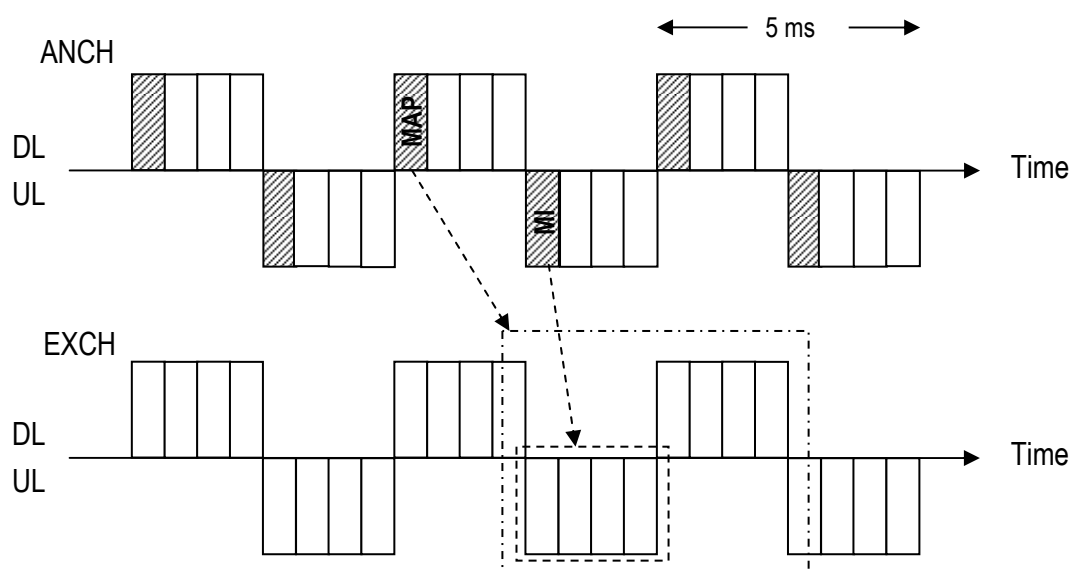

Figure 4.23 Example of DL MI Indication Timing in ECCH

4.3.6.5.1.2 MI Indication Timing of UL

Figure 4.24 shows an example of MI indication timing. Regardless of MAP allocation timing, UL MI applies to UL EXCH of the same frame as the UL ANCH that contains the MI.



(a) Timing 1 MAP Allocation

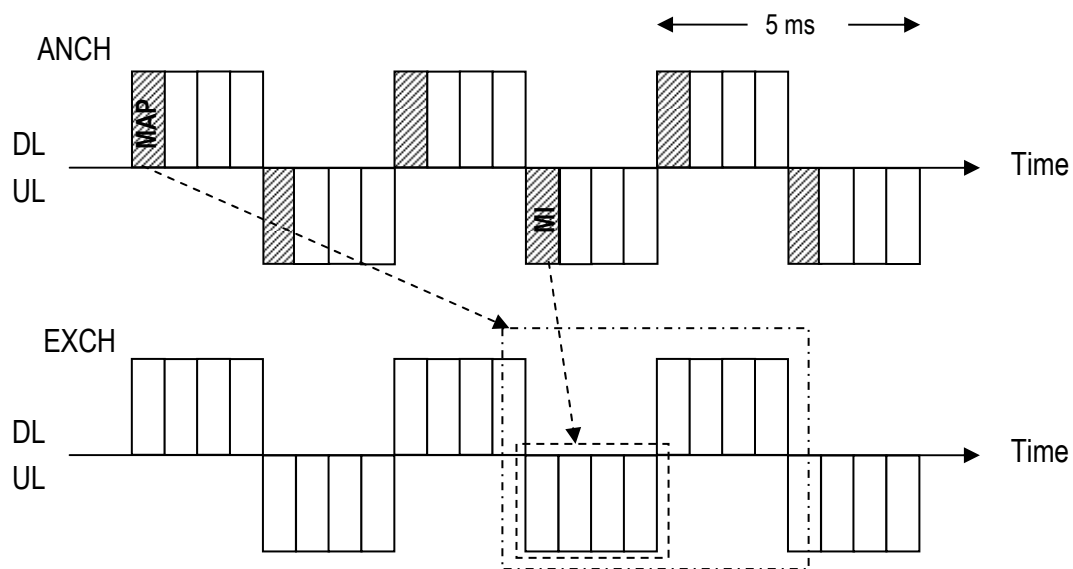

(b) Timing 2 MAP Allocation

Figure 4.24 Example of UL MI Indication Timing in ECCH

4.3.6.5.2 MI and MR in CSCH

In CSCH, MI and MR show the MCS of the PRU itself under communication.

4.3.6.5.2.1 MI Indication Timing of DL

Figure 4.25 shows the frame position where MI field of DL PHY header is applied. MI applies to the DL PHY payload following DL PHY header in the same frame.

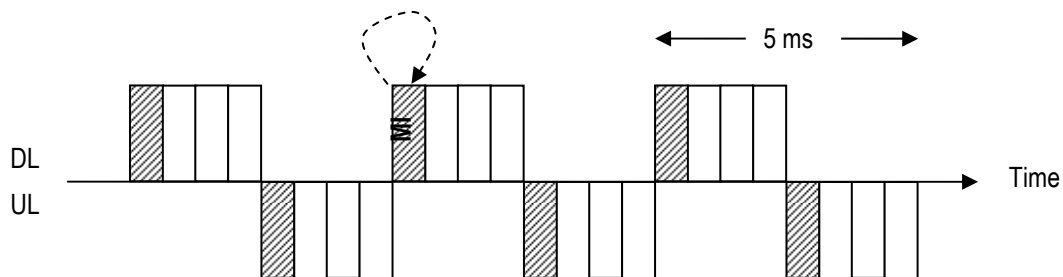

Figure 4.25 DL MI Indication Timing in CSCH

4.3.6.5.2.2 MI Indication Timing of UL

Figure 4.26 shows the frame position where MI field of UL PHY header is applied. MI applies to the UL PHY payload following UL PHY header in the same frame.

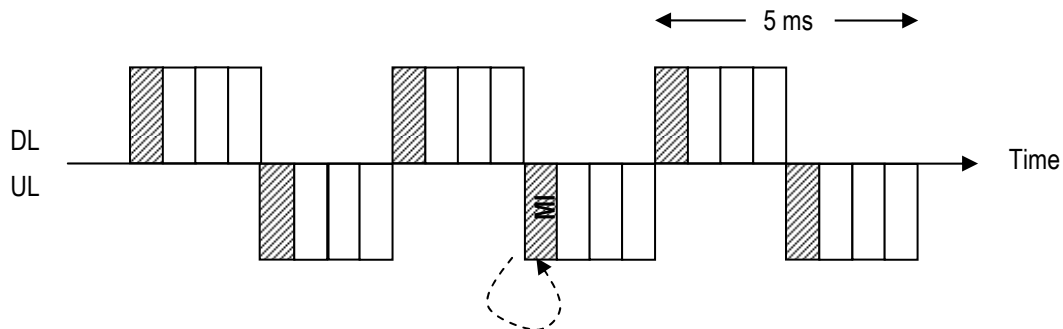

Figure 4.26 UL MI Indication Timing in CSCH

4.3.6.6 Acknowledgement (ACK)

This field indicates the acknowledgement of corresponding received data. Table 4.12 shows the value of the ACK field. This field is used for the acknowledgement of PHY layer retransmission control, such as HARQ. 0 stands for NACK. 1 stands for ACK.

Table 4.12 Value of ACK Field

ACK Value	Description
0	0 stands for NACK.
1	1 stands for ACK.

4.3.6.6.1 ACK in ECCH

This field indicates the acknowledgement of the data. The acknowledgement bit and the EDCHs correspond to each other in connected order of the PRU. The acknowledgement bits are allotted from the head corresponding to the EDCHs of the frame. (Refer to Section 9.2). The frame corresponds to the acknowledgement concerned transmission frame. ACK bits corresponding to the unused acknowledgement field are assumed invalid.

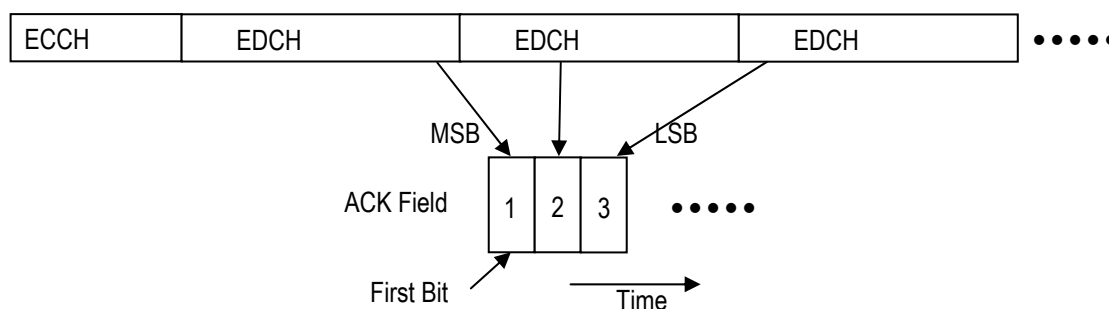

Figure 4.27 Correspondence between EDCH and ACK Field

4.3.6.6.1.1 Response Timing of DL ACK

DL ACK is generated based on CRC calculation and sent in the DL ANCH that comes three frames after UL EXCH reception.

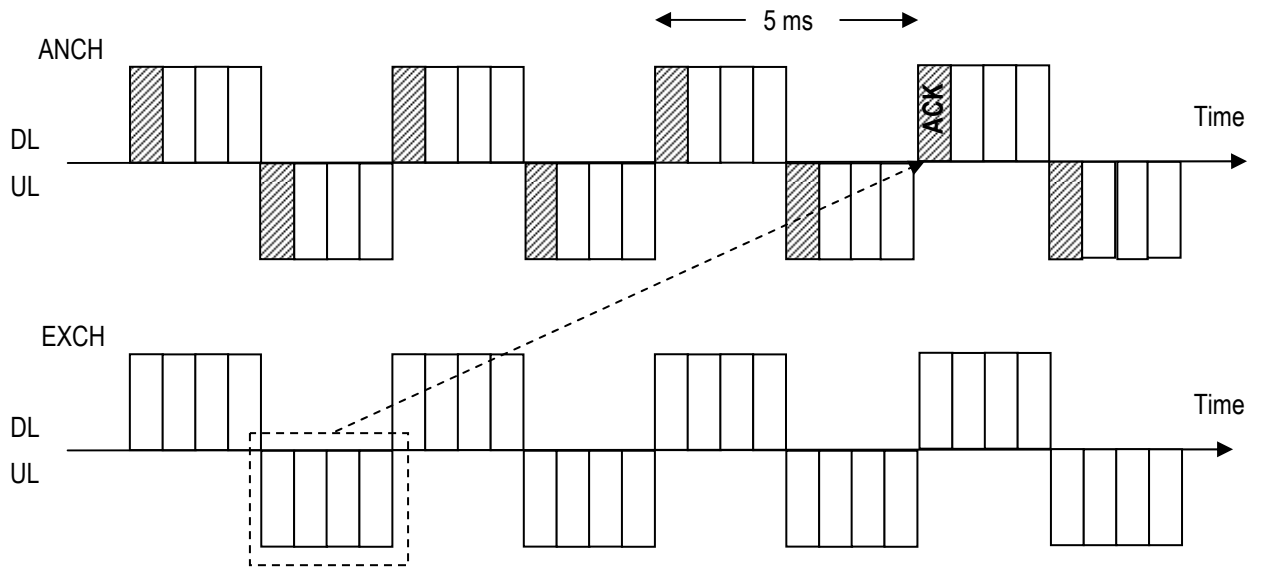

Figure 4.28 DL ACK Response Timing

4.3.6.6.1.2 Response Timing of UL ACK

Figure 4.29 shows UL ACK response timing. UL ACK is generated based on CRC calculation and sent in UL ANCH which comes two frames after DL EXCH reception.

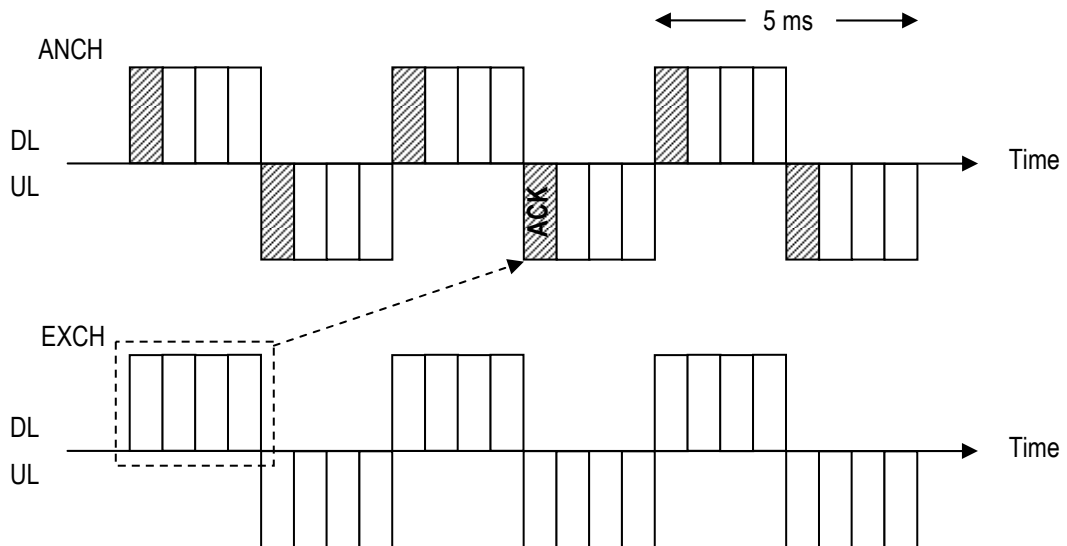

Figure 4.29 UL ACK Response Timing

4.3.6.6.2 ACK in CDCH

This field indicates the acknowledgement of the data.

4.3.6.6.2.1 Response Timing of DL ACK

Figure 4.30 shows the frame position where ACK field of DL PHY header is applied. DL ACK is generated based on CRC calculation and sent in the DL CDCH that comes 7.5 ms after UL CDCH reception.

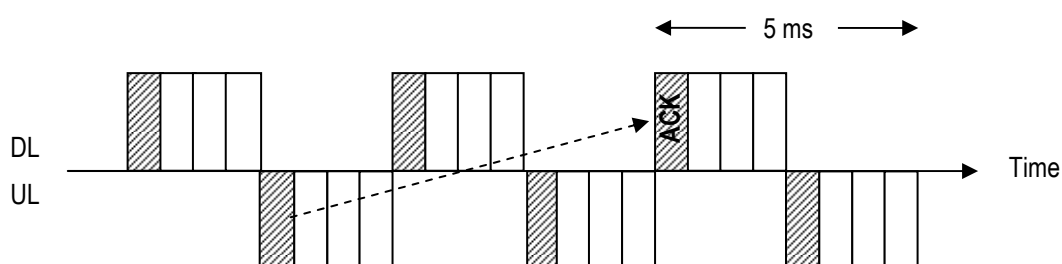

Figure 4.30 DL ACK Response Timing

4.3.6.6.2.2 Response Timing of UL ACK

Figure 4.31 shows the frame position where ACK field of UL PHY header is applied. UL ACK is generated based on CRC calculation and sent in the UL CDCH that comes 7.5 ms after UL CDCH reception.

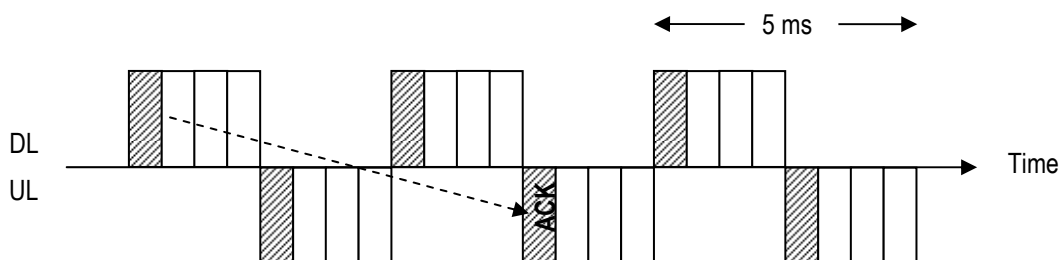

Figure 4.31 UL ACK Response Timing

4.3.6.7 MAP

The PRU numbers are assigned as shown in Figure 4.32. This number is called logical PRU number. MAP indicates logical PRU, which includes CCH PRU(s).

MAP origin indicates the starting point of the logical PRU number for the MS. BS decides MAP origin by negotiating with MS at access establishment phase.

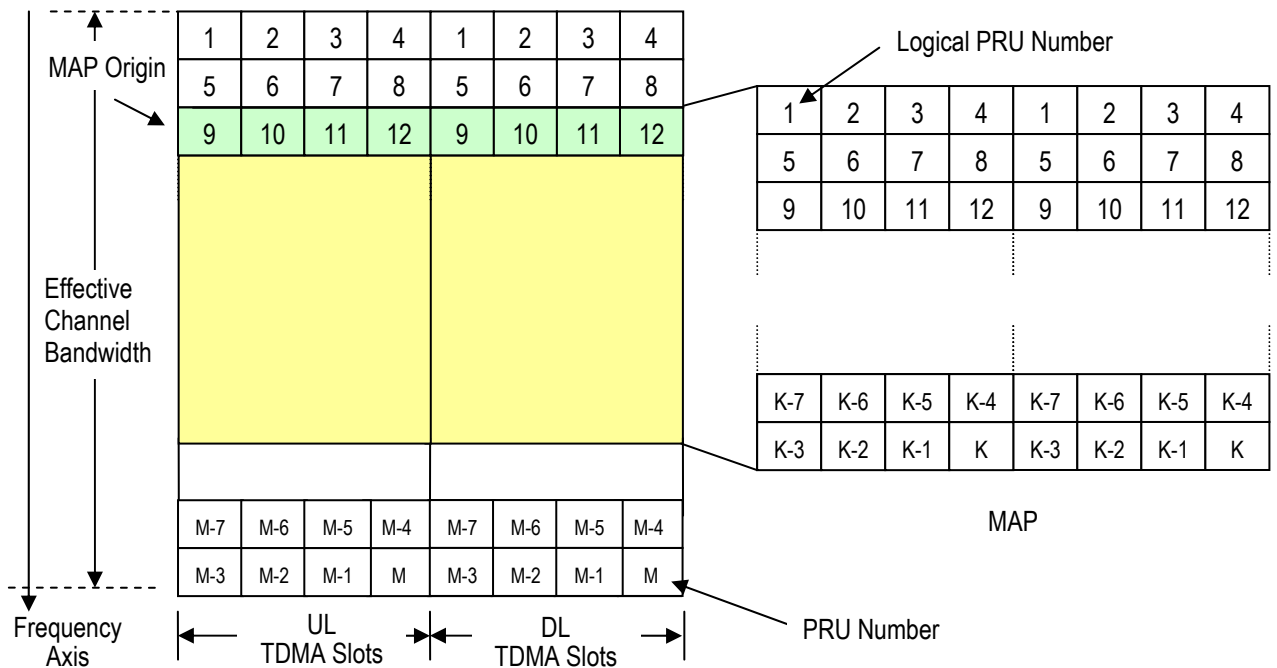

Figure 4.32 Logical PRU Numbering

Figure 4.33 shows the relationship between logical PRU number and the bit assignment in the MAP field. Logical PRU number is assigned from the top of the MAP field. 1 stands for the allocated PRU and 0 stands for not allocated ones.

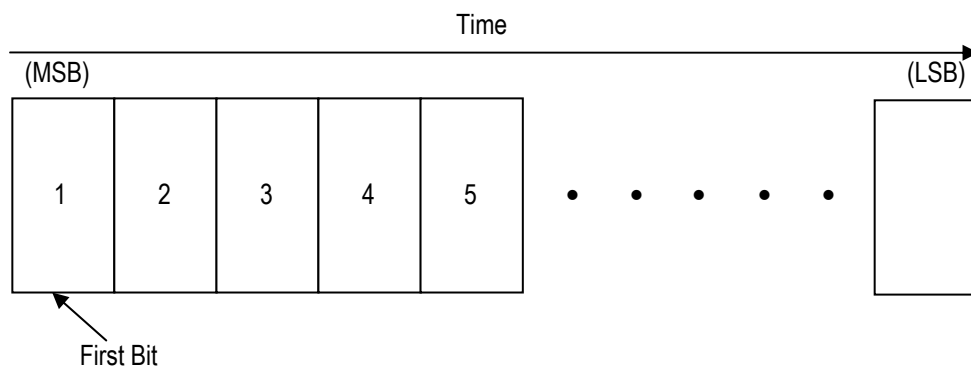
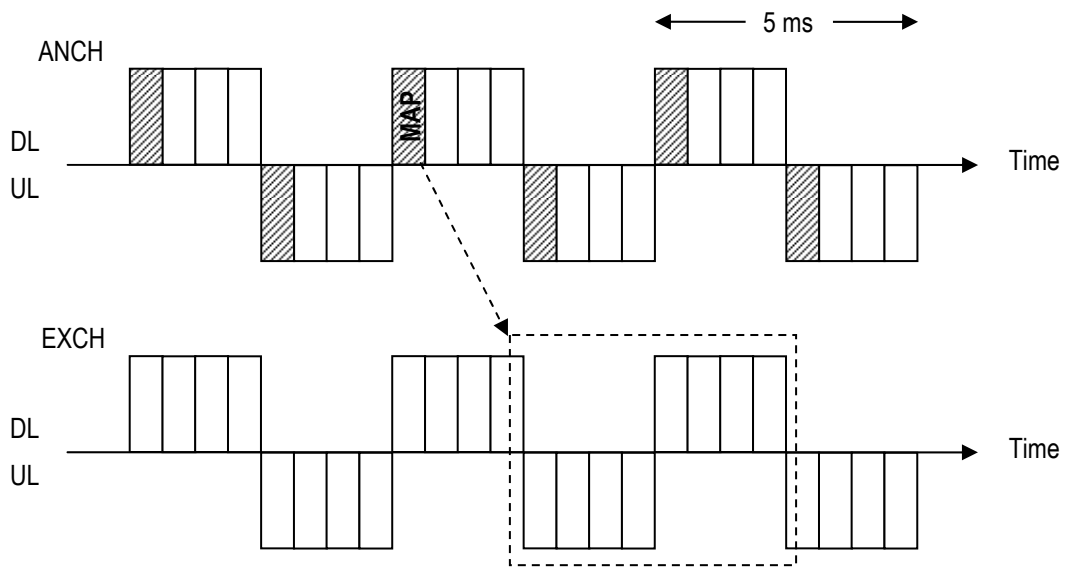

Figure 4.33 Correspondence between Logical PRU Number and Bit Position in the MAP Field

4.3.6.7.1 Response Timing of MAP

Figure 4.34 shows MAP indication timing. BS determines this response time for each MS by negotiating with the MS at access establishment phase.

MAP field indicates the PRU which can be used as EXCH one frame after in case of (a) timing 1. It indicates the PRU which can be used as EXCH two frames after in case of (b) timing 2.



(a) Timing 1 Allocation

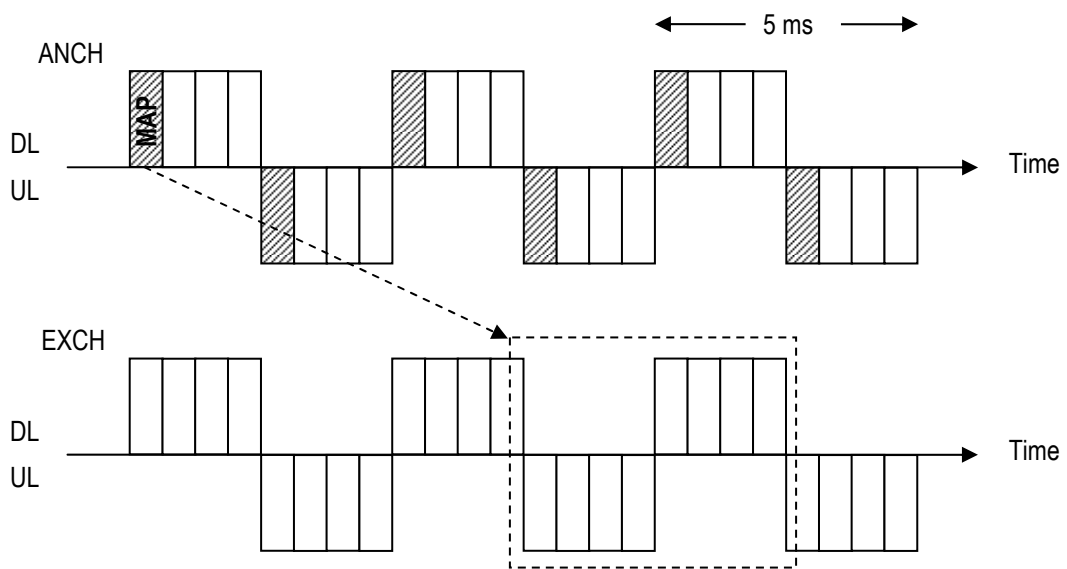

(b) Timing 2 Allocation

Figure 4.34 Example of MAP Indication Timing

4.3.6.8 Validity (V)

This field shows the number of the PRU(s) that contains the valid data in a TDMA frame. The data is then transmitted from the beginning of the PHY frame. In case when no data is transmitted, DTX instead of user data will be put into the data symbols.

In DL ECCH, the length of V field, which shows the value of the TDMA frame, is 7 bits. In UL ECCH, V field is divided into four blocks and each block shows the value of each of the slot.

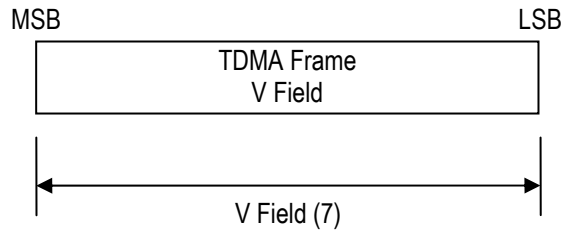

Figure 4.35 V field Structure in DL ECCH

Figure 4.36 shows an example of transmitting with DL OFDM when V field is 5. PRU(s) indicated by the V field is recognized as a PHY data unit. Remaining PRU(s) will carry DTX.

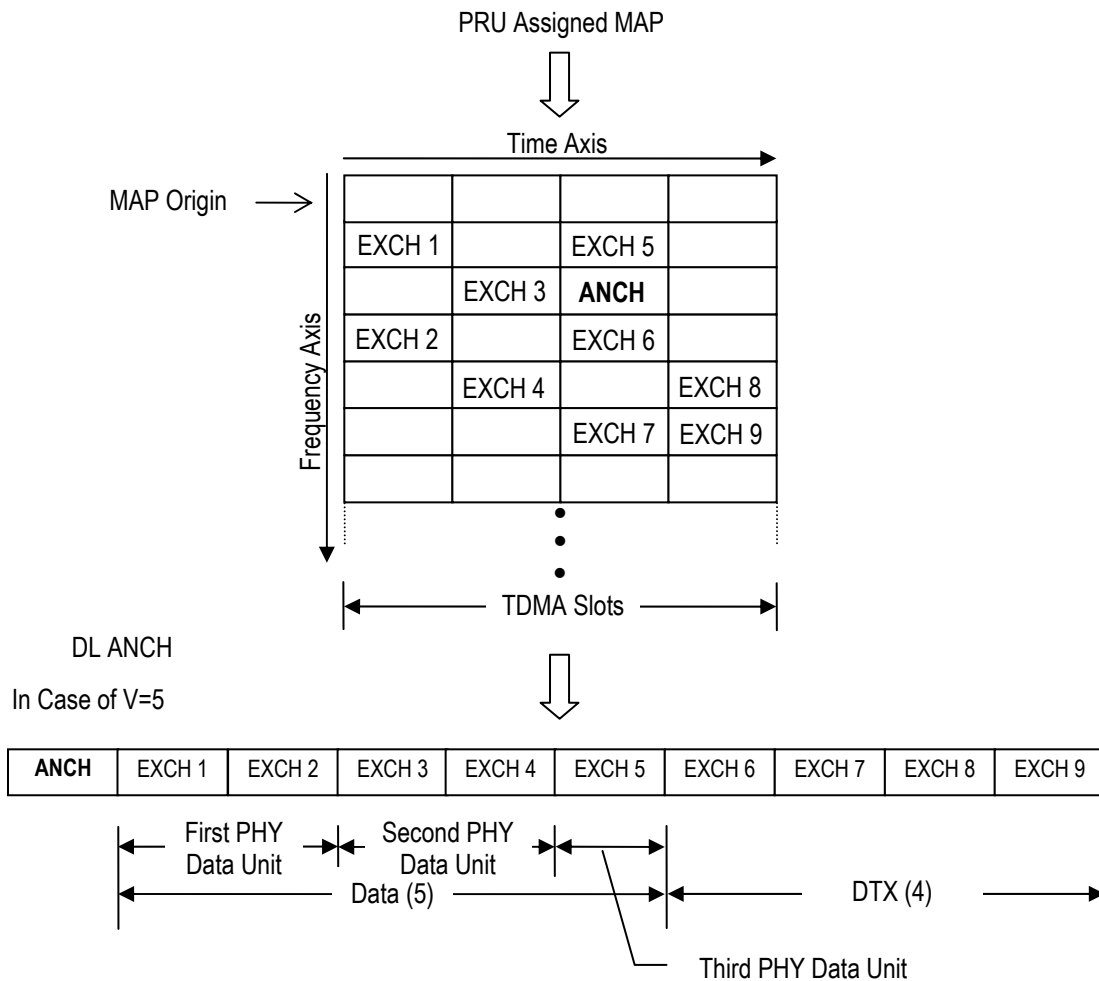

Figure 4.36 Example of Recognition Method of Data Burst and DTX from MAP Field for V as 5

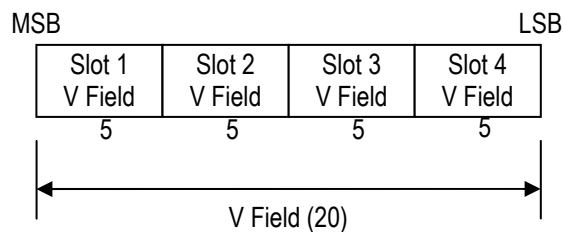

Figure 4.37 V Field Structure in UL ECCH

Figure 4.38 shows an example of transmitting with UL OFDM when V fields are (Slot 1=2, Slot 2=0, Slot 3=1, Slot 4=2) respectively. PRU(s) indicated by the V field is recognized as a PHY data unit. Remaining PRU(s) will carry DTX.

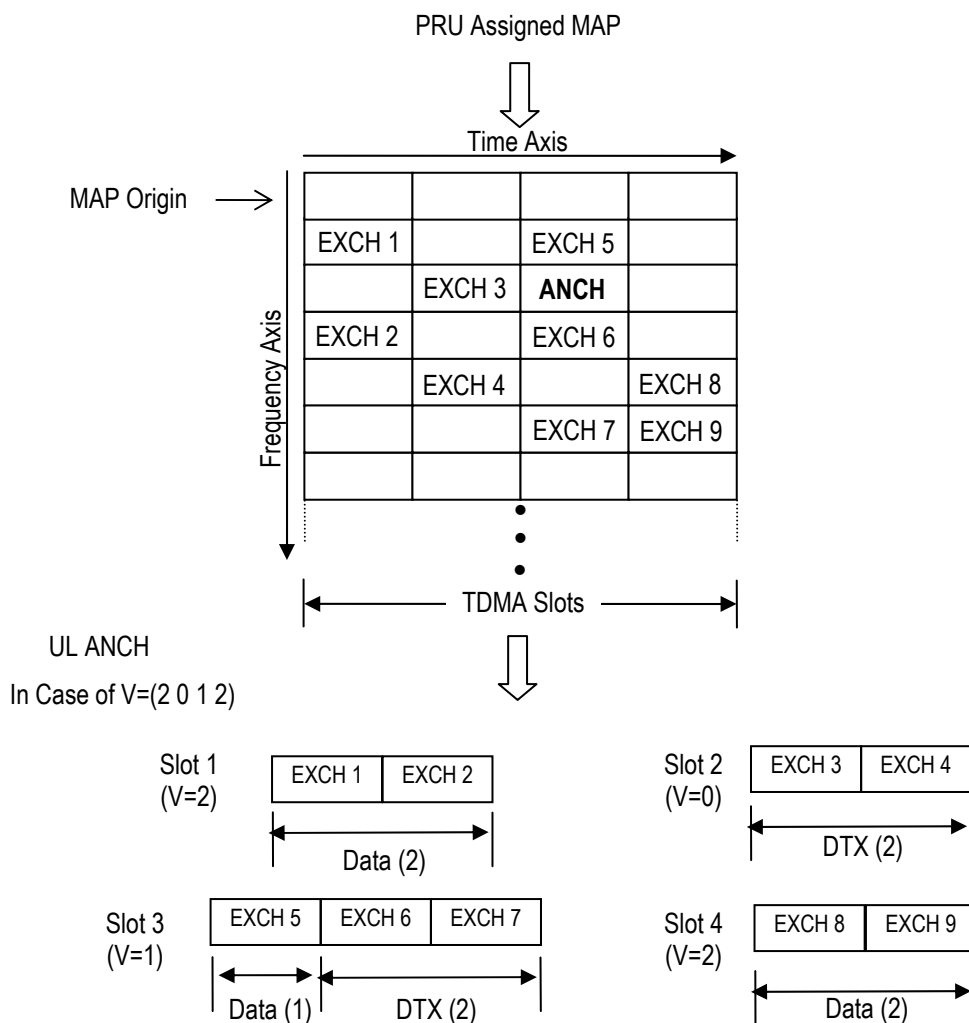

Figure 4.38 Example of Recognition Method of Data Burst and DTX from MAP Field for V as (2,0,1,2)

Used PRU numbers and positions when performing HARQ retransmission are specified in HARQ rule described in section 9.2.2.2, so sender and receiver share these structure. V indicates PRU number for HARQ retransmission data and new data (includes MAC-ARQ retransmission data); V ignores DTX PRUs.

Figure 4.39 shows an example of V value of DL in case of performing HARQ. In this case, 15 PRUs are assigned in the MAP in ANCH. There is a PRU of new data and 5 PRUs of HARQ retransmission data. HARQ data are pushed into smaller numbered SCHs in each slot. V indicates PRU number that has valid data.

MAP=15, V=6

				SCH1
ANCH	HARQ	HARQ	HARQ	SCH2
HARQ	HARQ	DTX	DTX	SCH3
Data	DTX	DTX	DTX	SCH4
DTX	DTX	DTX	DTX	SCH5
				:

Figure 4.39 Example of V value of DL in case of performing HARQ

4.3.6.8.1 V Indication Timing of DL

Figure 4.40 shows an example of V indication timing. DL V applies to the EXCH to which the MAP is in the same ANCH points.

DL V field indicates the number of valid EDCH(s) one frame after in the case of (a) timing 1. It indicates the number of valid EDCH(s) two frames after in the case of (b) timing 2.

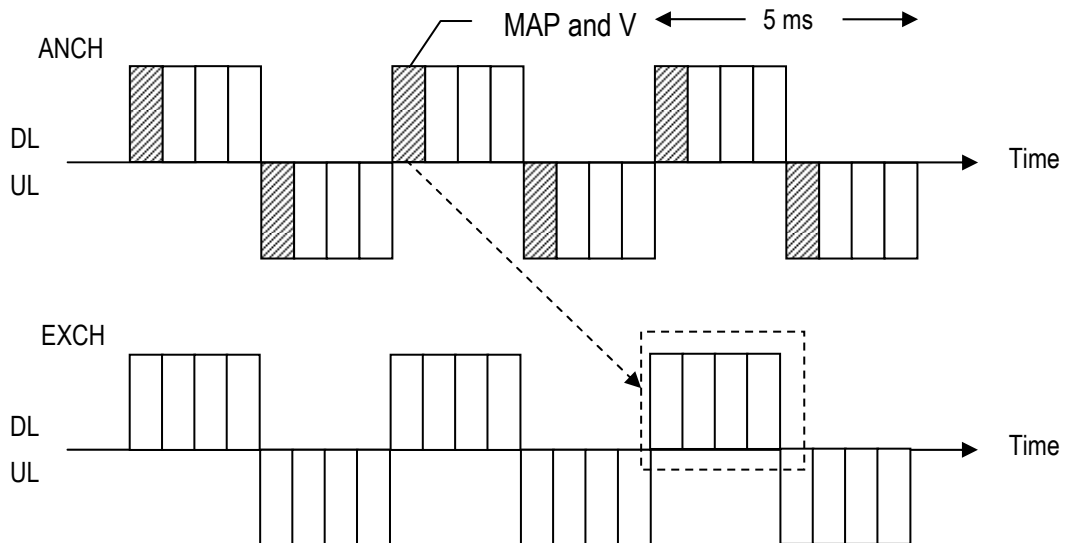

(a) Timing 1 MAP Allocation

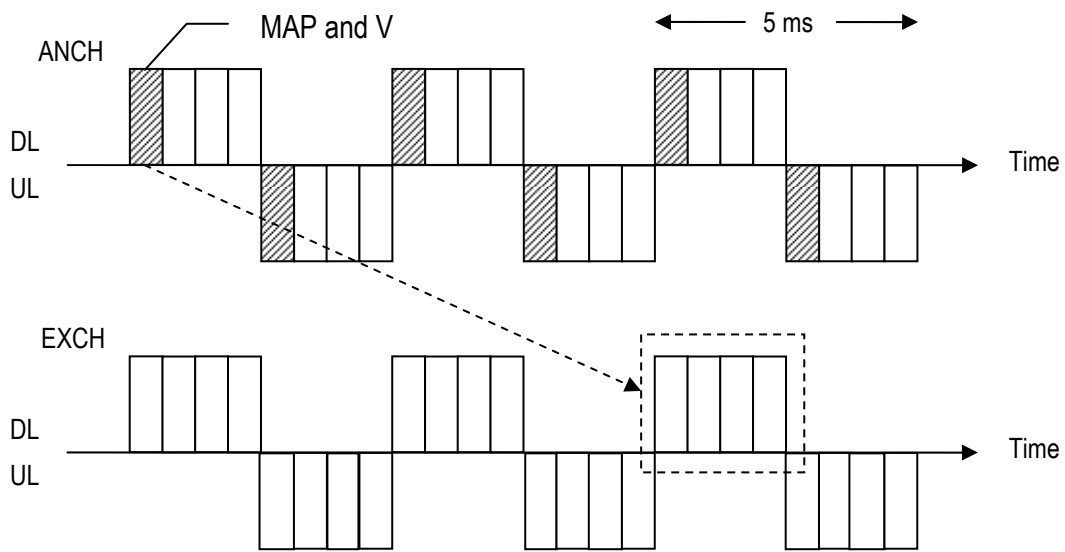

(b) Timing 2 MAP Allocation

Figure 4.40 V Indication Timing in DL ECCH

4.3.6.8.2 V Indication Timing of UL

Figure 4.41 shows an example of V indication timing. Regardless of MAP allocation timing, UL V applies to the UL EXCH of the same frame as the UL ANCH that contains the V. The MAP response time for each MS is determined by negotiation at access establishment phase.

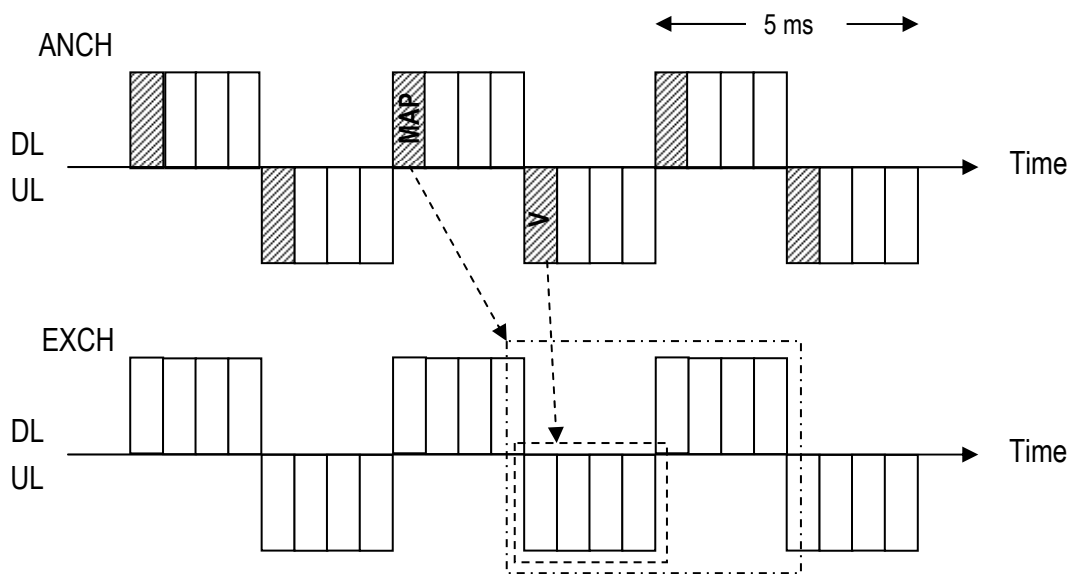

(a) Timing 1 MAP Allocation

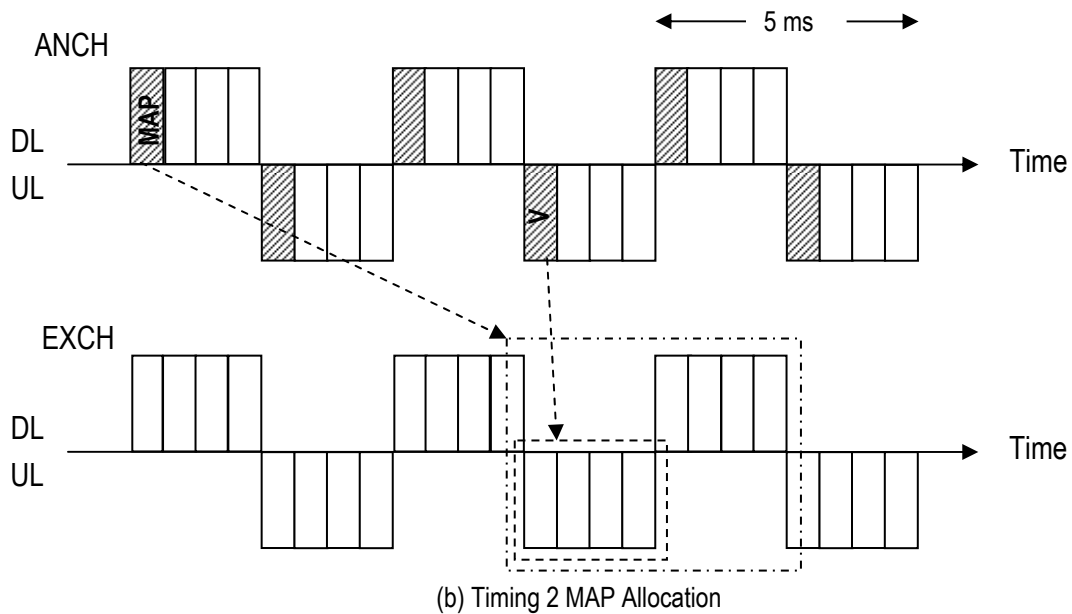

Figure 4.41 V Indication Timing in UL ECCH

4.3.6.9 HARQ Cancel (HC)

This field indicates cancellation of HARQ. HARQ can be activated when some conditions are fulfilled. MS or BS received set-to-1 HC field, cancels the HARQ process. Refer to Section 4.3.3.2.1.

Table 4.13 Value of HC Field

HC Value	Description
0	HARQ Enable
1	HARQ Cancel

4.3.6.9.1 HC Indication Timing of DL

Figure 4.42 shows an example of HC indication timing. DL HC applies to the EXCH to which the MAP is in the same ANCH points.

DL HC field indicates whether HARQ one frame later is valid or not in case of (a) timing 1. It indicates whether HARQ two frames later is valid or not in case of (b) timing 2.

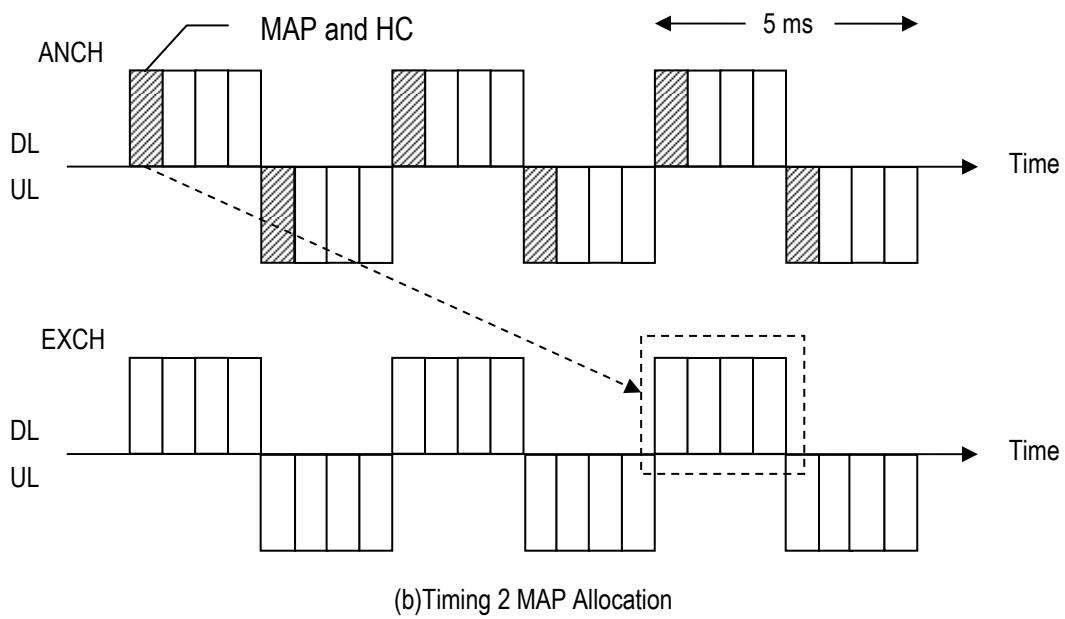
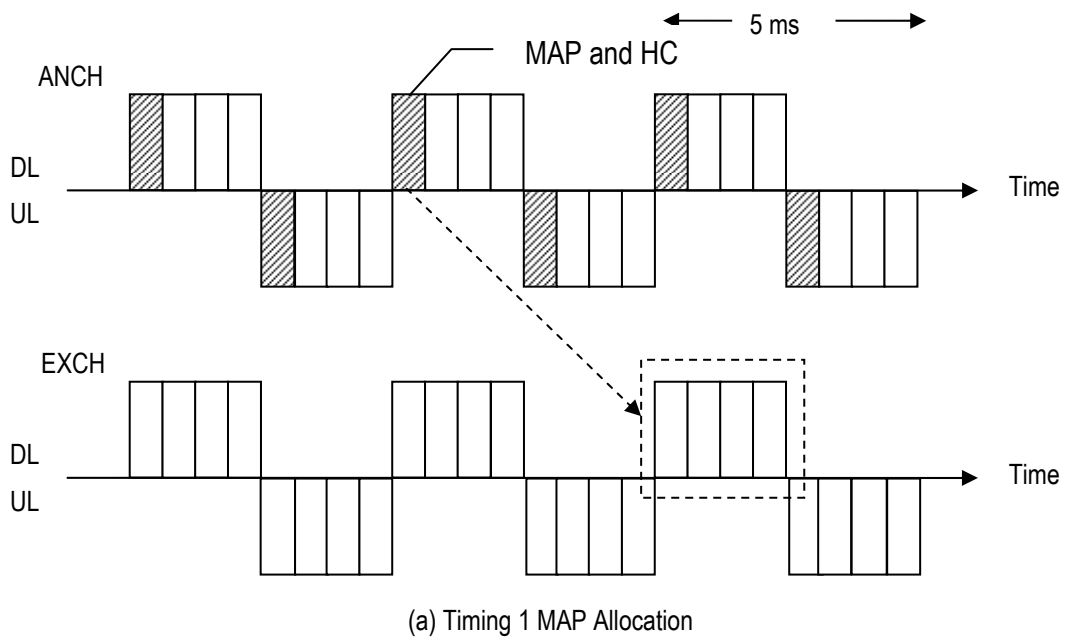

Figure 4.42 HC Indication Timing in DL ECCH

4.3.6.9.2 HC Indication Timing of UL

Figure 4.43 shows an example of HC indication timing. Regardless of MAP allocation timing, UL HC applies to the UL EXCH in the same frame as the UL ANCH that contains the HC.

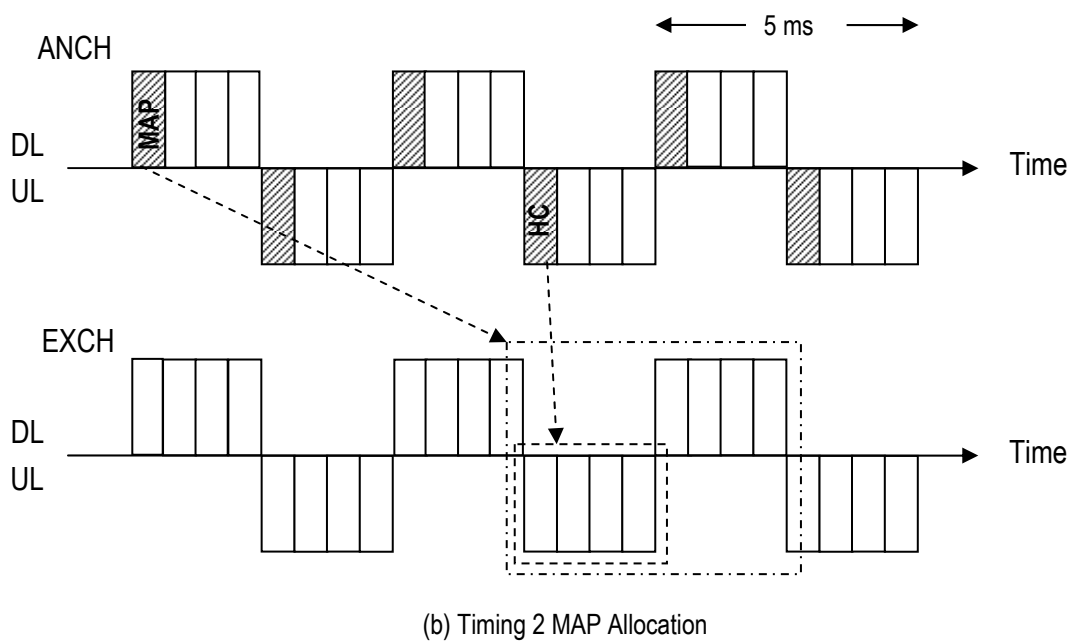
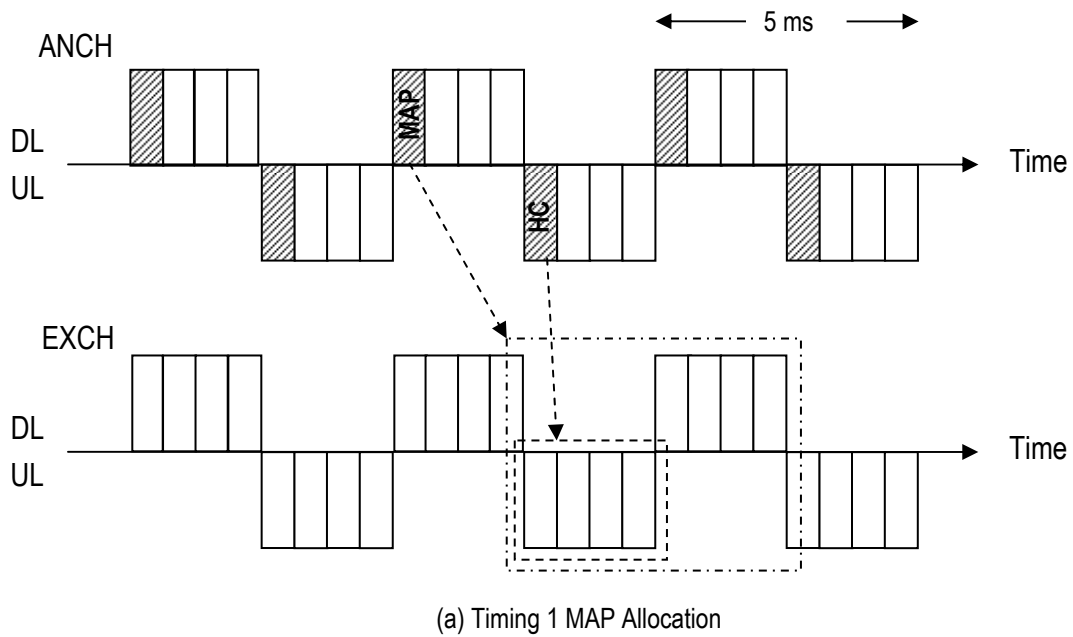

Figure 4.43 HC Indication Timing in UL ECCH

4.3.6.10 Request Channel (RCH)

This field is used for the bandwidth allocation request or transmission power margin notification from the MS to BS. The type of content is distinguished by identifier in RCH field. MS informs BS of data size to be sent.

Figure 4.44 shows structure of the RCH field.

Bit	7	6	5	4	3	2	1
	Identifier		Data				

Figure 4.44 RCH field

Table 4.14 Value of Identifier Field

Bit		Data Identifier of RCH Field
7	6	
0	0	UL Data Size Notification
0	1	Transmission Power Margin Notification
1	0	Reserved
1	1	Reserved

4.3.6.10.1 UL Data Size Notification

Figure 4.45 shows UL Data Size Notification format. This field is used for the bandwidth allocation request from the MS to BS. MS informs BS of data size to be sent.

Bit	7	6	5	4	3	2	1
	0	0	Unit		Data Length		

Figure 4.45 UL Data Size Notification

Table 4.15 Unit Field

Unit			
Bit	5		4
	0	0	MAC layer control message
	0	1	100 bytes
	1	0	1 kbytes
	1	1	10 kbytes

For example, Unit="0 1" (100 bytes), Data Length="1 0 0" then it indicates 400 bytes. Note that it does not show accurate value.

4.3.6.10.2 Transmission Power Margin Notification

Figure 4.46 shows Transmission Power Margin Notification format. This field is used for the notification of transmission power margin from MS to BS. BS may refer to this value when BS allocates PRU.

Bit	7	6	5	4	3	2	1
	0	1	Transmission Power Margin Notification				

Figure 4.46 Transmission Power Margin Notification

Table 4.16 Transmission Power Margin Notification

Transmission Power Margin Notification

Bit					
5	4	3	2	1	
0	0	0	0	0	0 dB
0	0	0	0	1	1 dB
0	0	0	1	0	2 dB
		:			
1	1	1	1	1	31 dB

4.3.7 Summary of PHY Frame Format

Figure 4.47 shows all PHY frame formats.

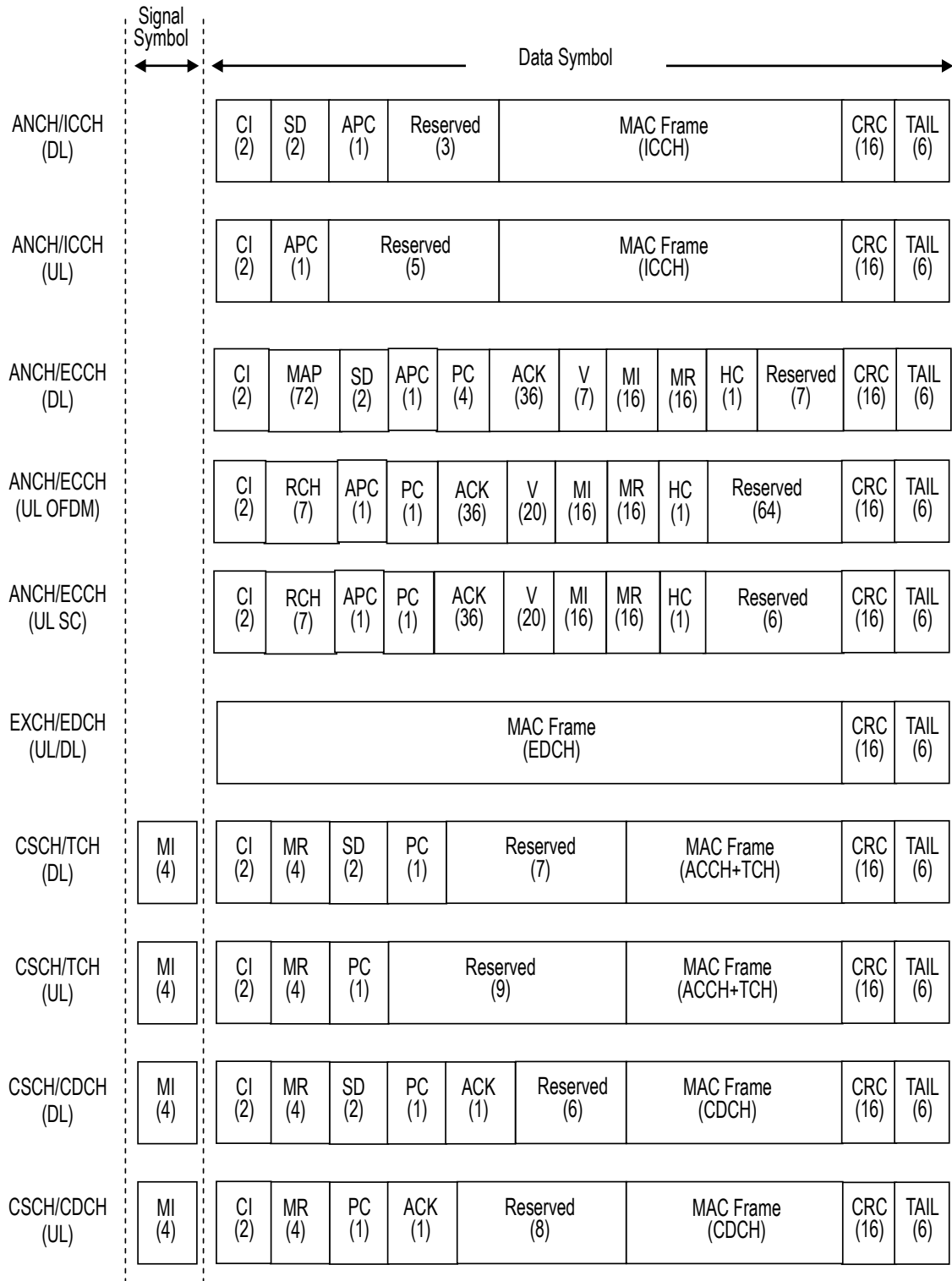

Figure 4.47 ICH PHY Frame Format

4.4 MAC Layer Structure and Frame Format

4.4.1 Overview

4.4.1.1 Format Regulations

Figure 4.48 shows basic format regulations used in this specification. The bit in single octet is horizontally aligned, and numbered from 1 to 8. Multiple octets are vertically aligned, and the numbered is put from 1 to n.

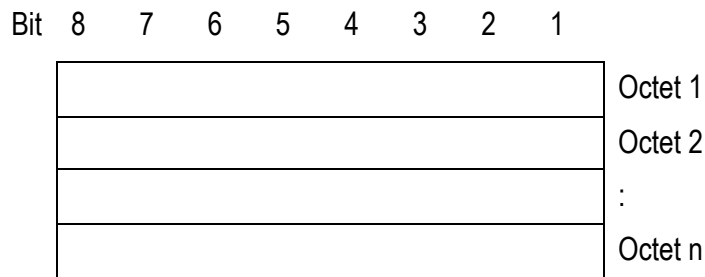

Figure 4.48 Format Regulations

The transmission is started from Bit 8 in Octet 1.

The format shown in Figure 4.49 is used when the list of a specific information types is in application. The bit row that shows each information is horizontally aligned.

Information Name	Bit	8	7	6	5	4	3	2	1

Figure 4.49 Format that shows List of Information Type

The format shown in Table 4.17 is used to explain the meaning of an individual bit. The meaning of the specific bit of 0 or 1 is tabulated and shown.

Table 4.17 Format for Explanation of Bit

Bit 1	
0	
1	

4.4.1.2 MAC Frame Composition

Figure 4.50 shows the outline of MAC frame composition procedure. The figure gives an example

of data transmission. Firstly, as much as possible upper layer data are combined. The data length, referred to as L_n , indicates each combined data when combination is performed. On the other hand, upper layer data exceeding PHY data unit size is fragmented. Then, sequence number N , which identifies each data transmission unit, is added. Finally, MAC header is to the MAC frames.

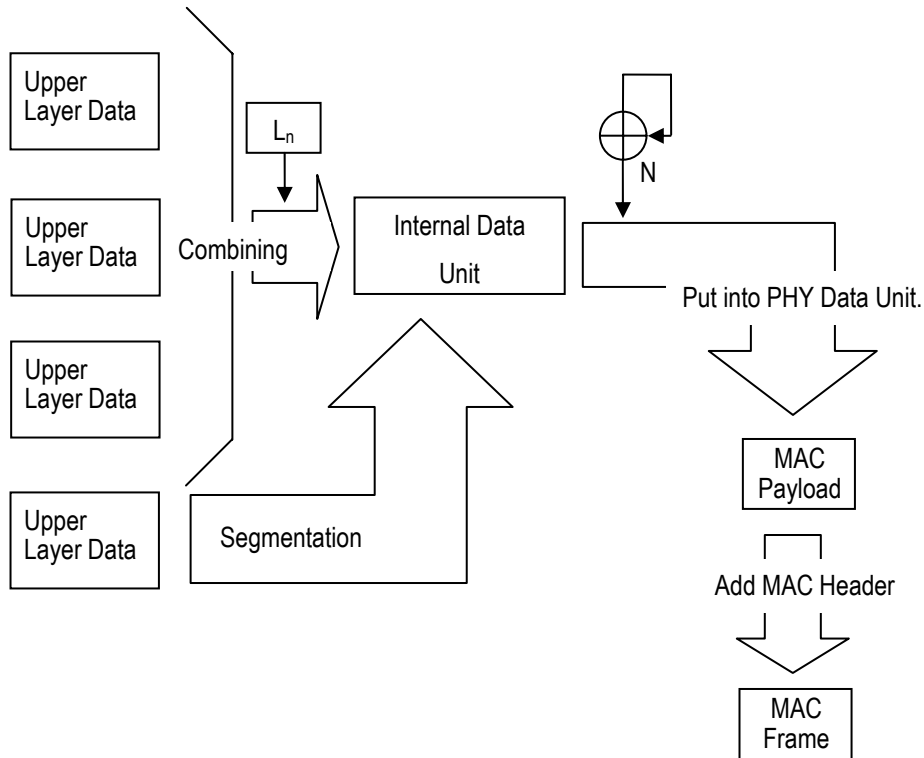

Figure 4.50 Procedure to Construct MAC Frame

At the reception side, upper layer data is reconstructed according to the MAC header.

4.4.2 MAC Frame Format

Figure 4.51 shows a general MAC frame structure and the order of bits and octets in the MAC frame. The MAC payload ends in byte boundary. The fraction bit of the PHY payload is PAD bit. PAD bits are from 0 bit to 7 bits. PAD is filled by 0. Transmission and reception are carried out from the upper bit. The first transmission and reception begin from the Octet 1.

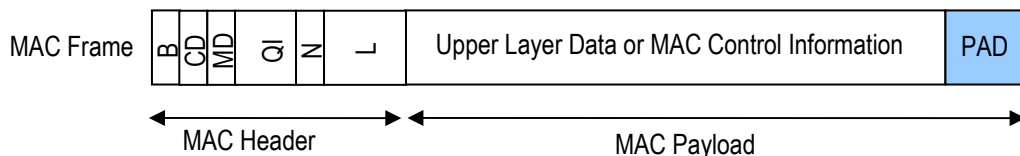

Figure 4.51 A General MAC Frame Structure (Included MAC Header)

According to the order of bits and octets that is described above, MAC frame composition is shown in Figure 4.52. Refer to Section 0 for detail.

Bit	8	7	6	5	4	3	2	1	
	B	CD		MD/F	QI				Octet 1
	N								Octet 1a
	E	L/IX (MSB)							Octet 2
	L/IX (LSB)								Octet 2a
	E	IX (MSB)							Octet 3
	IX (LSB)								Octet 3a
	Upper Layer Data, MAC Control Information								Octet 4...

Figure 4.52 Bit Order in MAC Frame

4.4.2.1 MAC Frame Structure

4.4.2.1.1 ICCH, EDCH and CDCH

Figure 4.53 shows the configuration of ICCH, EDCH, and CDCH. They contain a MAC header and MAC payloads.

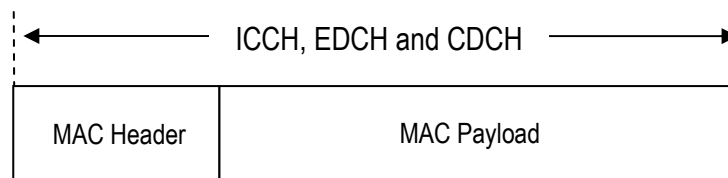

Figure 4.53 Configuration of ICCH, EDCH and CDCH

4.4.2.1.2 TCH

Figure 4.54 shows the configuration of TCH. TCH does not have a MAC header but contains voice data.

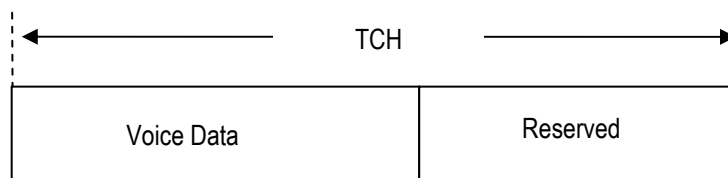

Figure 4.54 Configuration of TCH

4.4.2.1.3 ACCH

ACCH is an accompanying channel. Control messages on ACCH can be transmitted with user traffic simultaneously.

4.4.2.1.3.1 Frame Structure

Figure 4.55 shows the control message of ACCH, and its relation with Layer 2 frame.

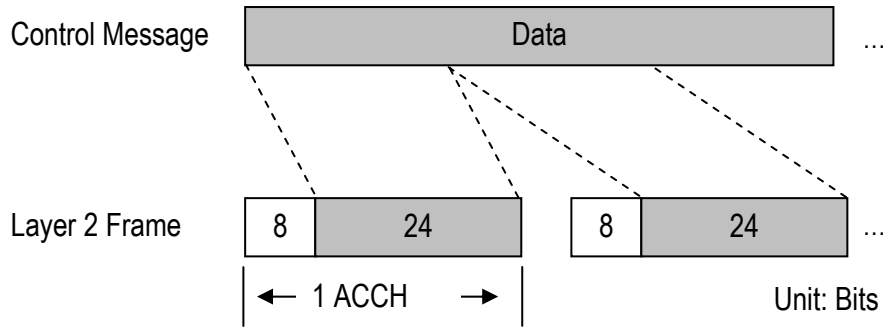

Figure 4.55 Relation between Control Message and Layer 2 Frame

4.4.2.1.3.2 ACCH Layer 2 Frame Signal Structure

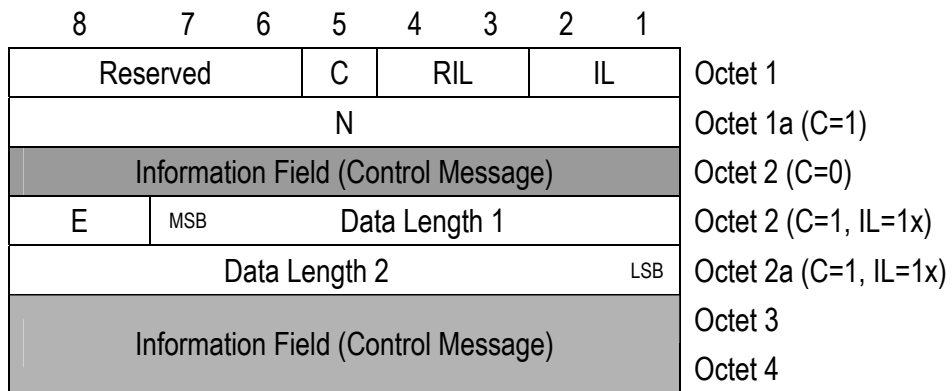

Figure 4.56 Layer 2 Frame Signal Structure of ACCH

- Information Link Bit (IL)

Bit		Description
2	1	
0	0	Middle Frame
0	1	End Frame
1	0	Leading Frame
1	1	Undivided Frame

- Remaining Information Length Indication Bit (RIL)

Bit		Description
4	3	
0	0	Control Message length is no octet.(No message)
0	1	Control Message length is one octet.
1	0	Control Message length is two octets.
1	1	Control Message length is three octets.

- Control Message Bit (C)

Bit	Description
0	It indicates that the MAC payload is unnumbered control information.
1	It indicates that the MAC payload is numbered control information.

- Sequence Number (N)

When C=1, Sequence Number (N) is appended as Octet 1a. Following figure shows information element N.

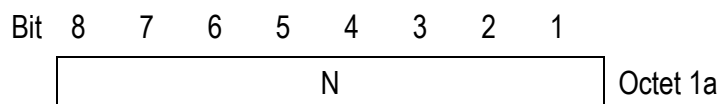

- Data Length

When IL=1x and C=1, Data Length is appended as Octet 2. Data Length field indicates MAC payload data length. It is shown by a byte unit. It can be expanded by using extension bit (E) depending on the value. Following figure shows information element Data Length. The bit E=0 if the value can be described within 7 bits. In this case, only the first octet (7 bits) is used, and the second octet is omitted. The bit E=1 if the value cannot be described 7 bits. In this case, two octets (15 bits) is used. Octet 2 shows upper 7 bits and Octet 2a shows lower 8 bits.

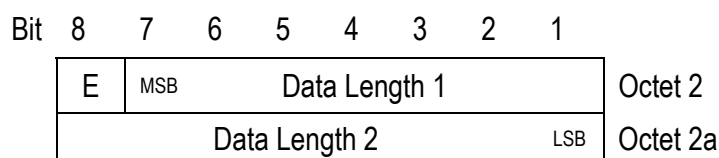

- Information Field

The message transferred on ACCH is considered QCS-ID=1.
When C=0, the message is stored in Octet 2~4. (3 Octets)

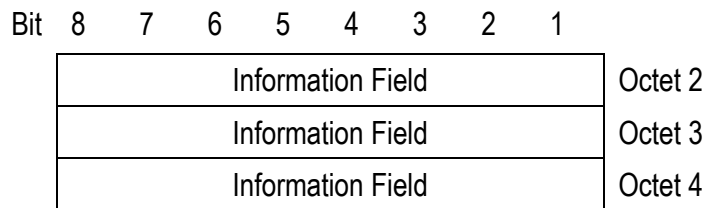

Otherwise, the message is stored in Octet 3~4. (2 Octets)

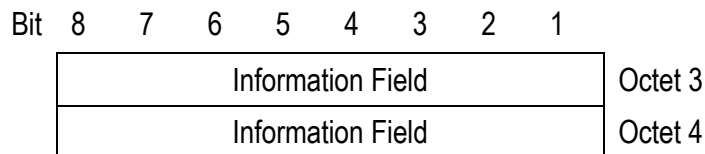

4.4.2.2 MAC Header

There are four basic types of different MAC frame headers as shown below:

Header of the MAC frame which carries,

1. the first segment of the segmented (Refer to Section 4.4.3.1) data, or the unsegmented data. That is when $B=1$, and $CD=x1$. The case of combining (Refer to Section 4.4.3.3) is included in this type. (Refer to Figure 4.57).
2. the second or later segment of the segmented data, and its MAC frame length is the same as PHY payload length. That is when $B=0$, $F=1$, and $CD=x1$. (Refer to Figure 4.58).
3. the second or later segment of the segmented data, and its MAC frame length is shorter than the PHY payload length. That is when $B=0$, $F=0$, and $CD=x1$. (Refer to Figure 4.59).
4. unnumbered control information. That is when $B=1$ and $CD=00$. (Refer to Figure 4.60).

Details of each element in these figures are described in Section 4.4.2.2.1.

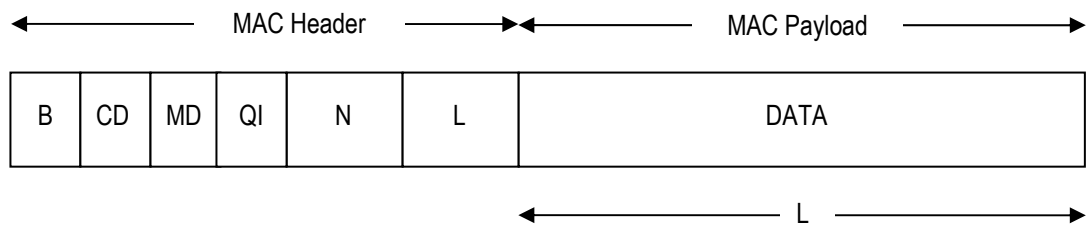

Figure 4.57 MAC Frame Format (1)

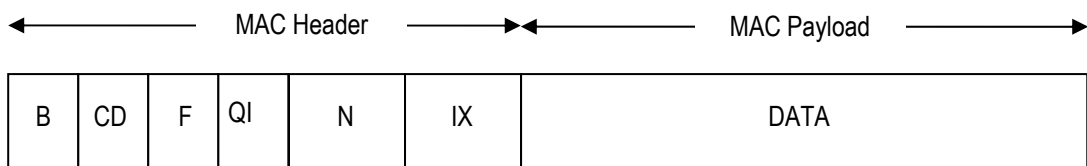

Figure 4.58 MAC Frame Format (2)

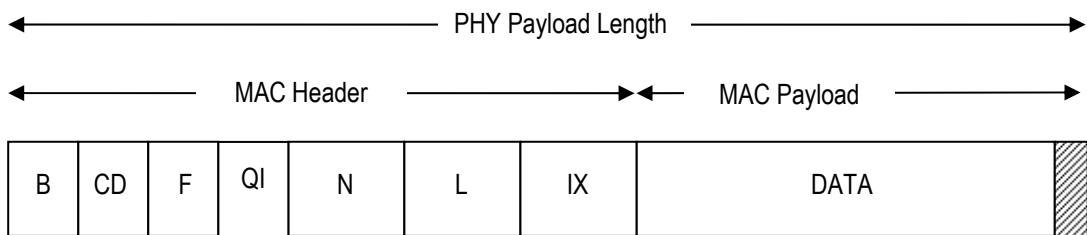

Figure 4.59 MAC Frame Format (3)

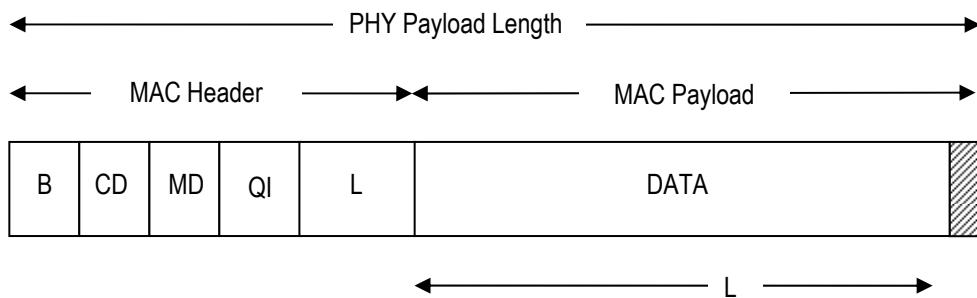

Figure 4.60 MAC Frame Format (4)

Table 4.18 shows the list of the information element included in the header of the MAC frame.

Table 4.18 Information Element List in MAC Header

Information Element Name	Sign	Information Length	Explanation
Frame Division Information	B	1 bit	It indicates the first frame of the set of divided segments or the frame of the second segments or later.
Identifier Control Information or Data	CD	2 bits	It identifies control information or data. It stands for the control information when the field is 00 or 01. It stands for the data when the field is 11. CD is referred by the MAC frame in case when B=1. CD does not have specific meaning in case when B=0.
Data Part Sharing	MD	1 bit	It indicates that the MAC payload contains single user data or multiple user data.
Identifier of the Payload Length	F	1 bit	It indicates that the data part length L equals to MAC payload length.
QCS-ID	QI	4 bits	It indicates the QCS-ID.
Sequence Number	N	8 bits	It indicates the sequence number.
Index	IX	8 or 16 bits	It indicates the number of bytes of upper layer data that has already been sent in the earlier MAC frames. Basically, it indicates the location of the upper layer data that the MAC payload is filled up.
Data Part Length	L	8 or 16 bits	It indicates data length contained in the MAC payload in case when MD=0. It indicates the total number of data lengths contained in the MAC payload in case when MD=1.
Data Length of User	L _n	8 or 16 bits	It indicates each length of multiple user data when MD=1.
Information Area	DATA		Upper layer data is included in the MAC payload.

4.4.2.2.1 Each Field of MAC Header

4.4.2.2.1.1 Frame Division Information (B)

B field shows the first frame in data transmission by dividing upper layer data into two or more MAC frames. It is used to restructure the divided transmission data.

Table 4.19 Frame Division Information

Bit 1	
0	The second frame or later when the upper layer data is divided.
1	The first frame when the upper layer data is divided or undivided frame

4.4.2.2.1.2 Data Type (CD)

CD field indicates whether the control information or upper layer data is included in the MAC payload. CD is referred by the MAC frame in case when B=1. CD is invalid and shall be set zero in case when B=0.

Table 4.20 Data Type

Bit		Identification
2	1	
0	0	It indicates that the MAC payload is unnumbered control information.
0	1	It indicates that the MAC payload is numbered control information.
1	0	Reserved
1	1	It indicates that the MAC payload is upper layer data.

4.4.2.2.1.3 Data Part Sharing (MD)

An identifier shows whether the MAC payload is shared by multiple upper layer data. Table 4.21 shows the definition of the MD field.

This information element is omitted when B=0.

Table 4.21 Data Part Sharing

Bit 1

0	Single upper layer data is included in a MAC payload.
1	Multiple upper layer data are included in a MAC payload.

4.4.2.2.1.4 Bit of Payload Length Identification (F)

An identifier indicates whether the MAC payload length is specified by L field or not, because the MAC frame length is the same as the PHY payload length. The bit definition of F field is as shown in Table 4.22.

This information element is omitted when B=1.

Table 4.22 Bit of Payload Surplus Judgment

Bit 1

0	The MAC payload is specified by L field.
1	Because PHY payload length is the same as the MAC frame length, the length of the MAC payload is not specified by L field.

4.4.2.2.1.5 QCS-ID (QI)

This number identifies the quality service sessions. QCS-ID is assigned for every session and managed between MS and BS. The length of this field is 4 bits. When control information which does not distinguish QCS is used, this value is set to 0 (QCS-ID=1). Otherwise it is set to any of the number from 1 to 15 to specify each QCS.

4.4.2.2.1.6 Sequence Number (N)

This is a series of continuous numbers to identify the data. N is supervised for each user and incremented by upper layer data unit or PHY data unit (CRC unit) for each QCS.

Increment Timing

1. In case of combining (Refer to Section 4.4.3.3), N is incremented by PHY data unit.
2. In case of segmentation (Refer to Section 4.4.3.2), N is incremented by upper layer data unit.
3. In case of concatenation (Refer to Section 4.4.3.4), N is incremented by upper layer data unit.
4. In other cases than combining segmentation or concatenation, N is incremented by PHY data unit (= upper layer data unit).

Table 4.23 Relation CD Field and Sequence Number

CD Field	Sequence Number
Unnumbered Control Information	It is no sequence number. Octet 1a is omitted.
Numbered Control Information Upper Layer Data	Sequence number is 8bits. Octet 1a is used.

4.4.2.2.1.7 Index (IX)

IX shows the numbers of the sent bytes from the beginning of the upper layer data. It also indicates the position of the upper layer data that this MAC payload is filled up.

The area of index can be expanded by using extension bit (E) depending on the value. Figure 4.61 shows information element IX, The bit E=0 if the value can be described within 7 bits. In this case, only the first octet (7 bits) is used, and the second octet is omitted. The bit E=1 if the value cannot be described within 7 bits. In this case, two octets (15 bits) is used. Octet 1 shows upper 7 bits and Octet 2 shows lower 8 bits.

This information element is omitted when B=1.

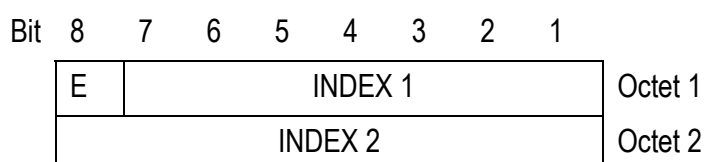

Figure 4.61 Format of Index Field

Table 4.24 Explanation of the Extension Bit of Octet 1

Bit 8	
0	Octet 2 (INDEX 2) is omitted.
1	Octet 2 (INDEX 2) is used.

4.4.2.2.1.8 Data Part Length (L)

L field indicates data length contained in the MAC payload when MD=0. It indicates the total number of data lengths contained in the MAC payload when MD=1. The data part length is shown by a byte unit.

The area of data part length can be expanded by using extension bit (E) depending on the value. Figure 4.62 shows information element L. The bit E=0 if the value can be described within 7 bits. In this case, only the first octet (7 bits) is used, and the second octet is omitted. The bit E=1 if the value cannot be described 7 bits. In this case, two octets (15 bits) is used. Octet 1 shows upper 7 bits and Octet 2 shows lower 8 bits.

This information element is omitted when F=1.

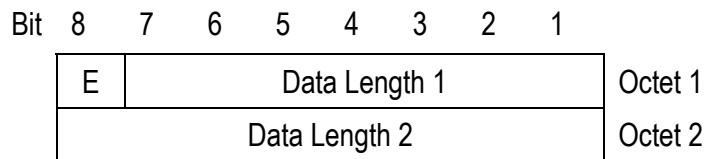

Figure 4.62 Data Part Length / User Data Length

Table 4.25 Explanation of the Extension Bit of Octet 1

Bit 8	
0	Octet 2 (data length 2) is omitted.
1	Octet 2 (data length 2) is used.

4.4.2.2.1.9 User Data Length (Ln)

When one MAC payload includes upper layer data for multiple upper layer data, this information element shows each upper layer data length. The format of the element uses the same data part length. Refer to Figure 4.62 and Table 4.25. This information element is omitted when MD=0.

4.4.2.2.1.10 Information Area (DATA)

This is the dedicated data area for the MAC frame. It includes upper layer data, MAC control protocol and access establishment phase control protocol information.

4.4.2.3 MAC Payload

There are two types of MAC payload as shown below:

- Upper Layer Data
- MAC Control Information

4.4.2.3.1 Upper Layer Data

When CD field in MAC header is upper layer data, upper layer data is included in MAC payload.

4.4.2.3.2 MAC Control Information

When CD field in MAC header is either unnumbered MAC control information or numbered MAC control information, MAC control information is included in MAC payload.

Satisfying following conditions, leading 2 bytes of upper layer data indicates network layer

protocol type.

- (1) CD=01 (Numbered Control Information)
- (2) QI is other than zero

When an upper layer data is segmented (Refer to section 4.4.3.1), the protocol type is only put on the first segment (Figure 4.63). This protocol type is a part of encrypted region.

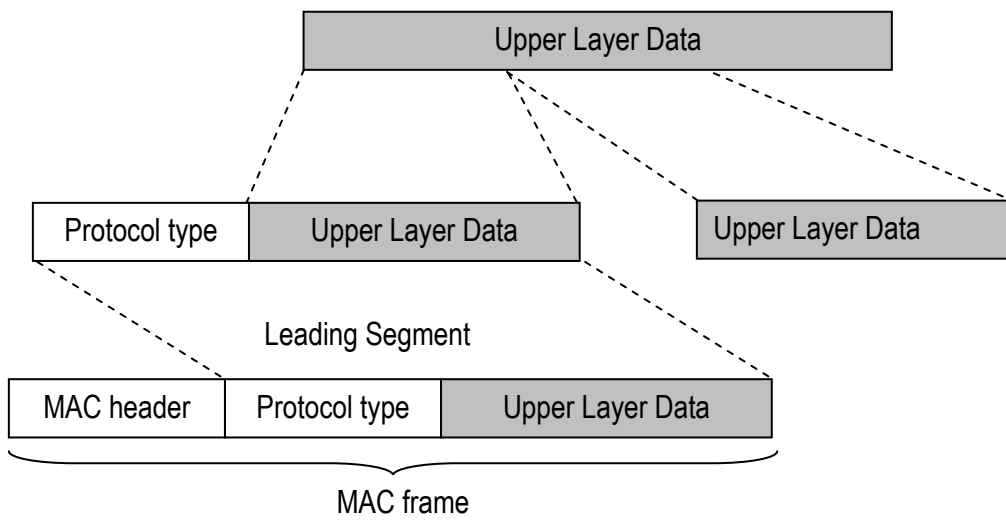

Figure 4.63 Relation between MAC Frame and Upper Layer Data with Protocol Type

4.4.3 Segmentation, Combining and Concatenation

4.4.3.1 Upper Layer Data Segmentation

Figure 4.64 shows the example, when the upper layer data which has data length of L bytes is segmented. In this example, the length of the last segment of the data segments is shorter than the PHY payload. At the reception side, data is reconstructed based on the information of L and IX.

The segmented data can be transmitted by not only single TDMA frame but also multiple TDMA frames.

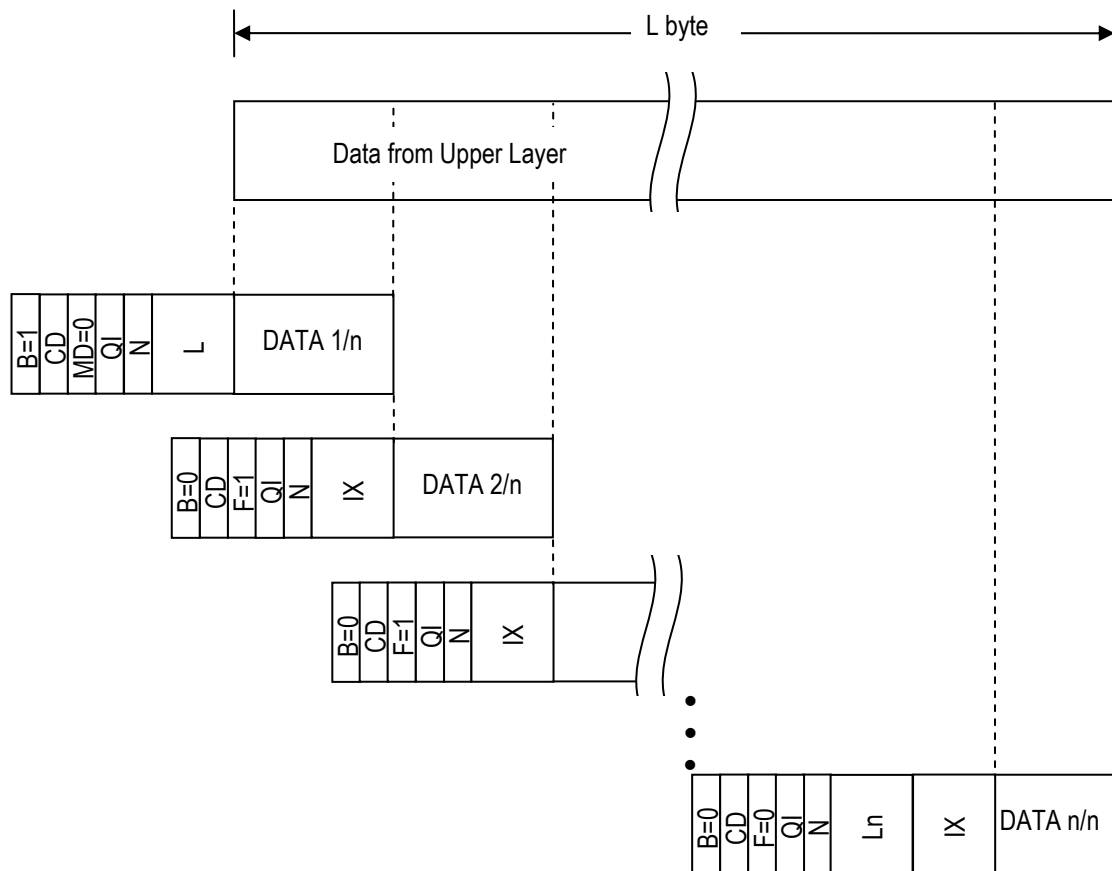

Figure 4.64 MAC Frame Segmentation

4.4.3.2 MAC Frame Segmentation in case of Retransmission

If the same bandwidth to precede retransmission cannot be allocated, this MAC frame will be segmented into multiple segments according to the allocated bandwidth for retransmission. N and MD of the retransmitted MAC frame use the same N and MD of the original MAC frame in the first segment. In the following segment(s), N will be the same and B will be set to 0.

Figure 4.65 shows the example of MAC retransmitting frame which is divided into two segments. In this example, frame length of the first segment of the MAC frame is the same as the PHY payload length. The length of the next segment of the MAC frame is shorter than the PHY payload length.

In case of Figure 4.65, the length of the second segmented frame is shorter than the PHY payload length, where $F=0$. IX shows the number of the data has already been sent from the head of the MAC payload to be retransmitted. $IX=L_0$ as shown in Figure 4.65 displays that MAC header is created by using the same rule, when the number of segmentation increases.

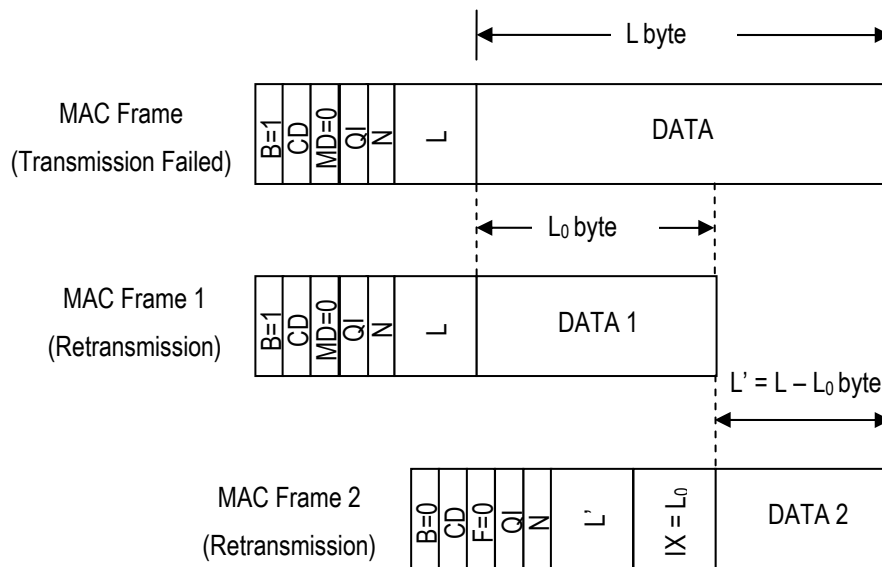

Figure 4.65 Data with MD=0 segmented in case of Retransmission

4.4.3.3 Combining Multiple Upper Layer Data into Single MAC Payload

Data length (L_1, L_2, \dots) of each data is added respectively when $MD=1$ as shown in Figure 4.66 when multiple upper layer data shares one MAC payload. L is the sum of data length with all data included.

$$L = \sum_{x=1}^n L_x \text{ in this case.}$$

The format $L' < \sum_{x=1}^n L_x$ will be applied when transmission carries forward to the N -th data.

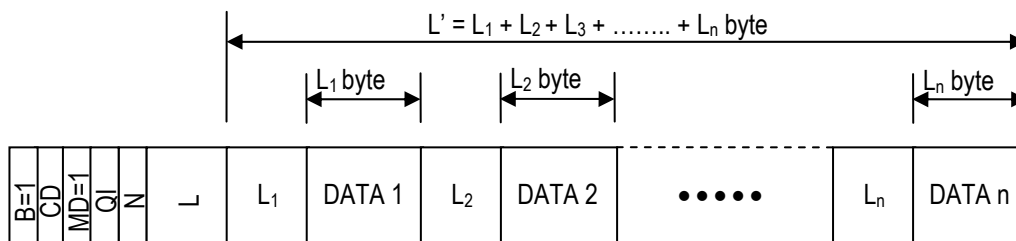

Figure 4.66 Combining Multiple Upper Layer Data into Single MAC Payload

When retransmission is performed, if the same bandwidth as preceding transmission cannot be allocated, this MAC frame will be segmented into multiple segments according to the allocated bandwidth for retransmission. Same N and MD of the MAC frame to be retransmitted will be used in the first segment. And N will be the same in the following segment and B will be 0.

Figure 4.67 shows the example of retransmitting MAC frame containing multiple upper layer data divided into two segments. In this example, frame length of the first segment of the MAC frame is the same as the PHY payload length. Length of the second segment of the MAC frame is shorter than the PHY payload length.

In case of Figure 4.67, length of the second segmented frame is defined to be shorter than the PHY payload length. Hence, $F=0$. IX shows the number of data sent from the head of the MAC payload to be retransmitted. $IX=L'$ as shown in Figure 4.67. MAC header is created using the same rule when the number of segmentation increases.

This feature is negotiated in information element Communication Parameter and MS Performance.

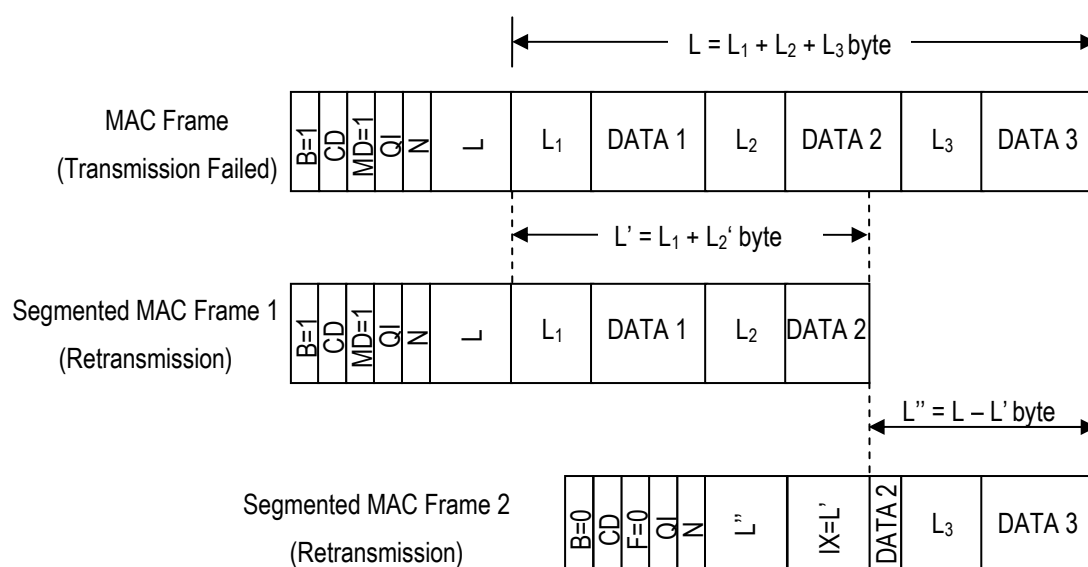

Figure 4.67 Data with MD=1 segmented in case of Retransmission

4.4.3.4 MAC Frame Concatenation

MAC frame concatenation is permitted with the following conditions. MAC frame concatenation here stands for multiple MAC frame to be included in a PHY data unit. Subsequent 24bits of last concatenated MAC frame are set to all 0. Satisfying following conditions, further MAC frame can be concatenated.

- PHY Payload Length – Current total MAC Frame Length ≥ 4 bytes
- Twenty-four leading bits of trailing MAC frame is not all zero.

Figure 4.68 shows an example when MAC frames are concatenated in a PHY payload. In the example, 55 bytes upper layer data is followed by 150 bytes data. In a TDMA frame, PHY data unit can transmit 43 bytes data when MCS is BPSK-1/2. In first TDMA frame, 40 bytes segmented data can be transmitted. Then transmission of the rest of 15 bytes segmented data will be continued to next TDMA frame.

In the next TDMA frame, 24 bytes data can be transmitted in addition to the rest of 15 bytes segmented data, due to the fact that the difference between PHY payload length and first MAC frame length is bigger than 4 bytes. Other conditions are satisfied in the sample case.

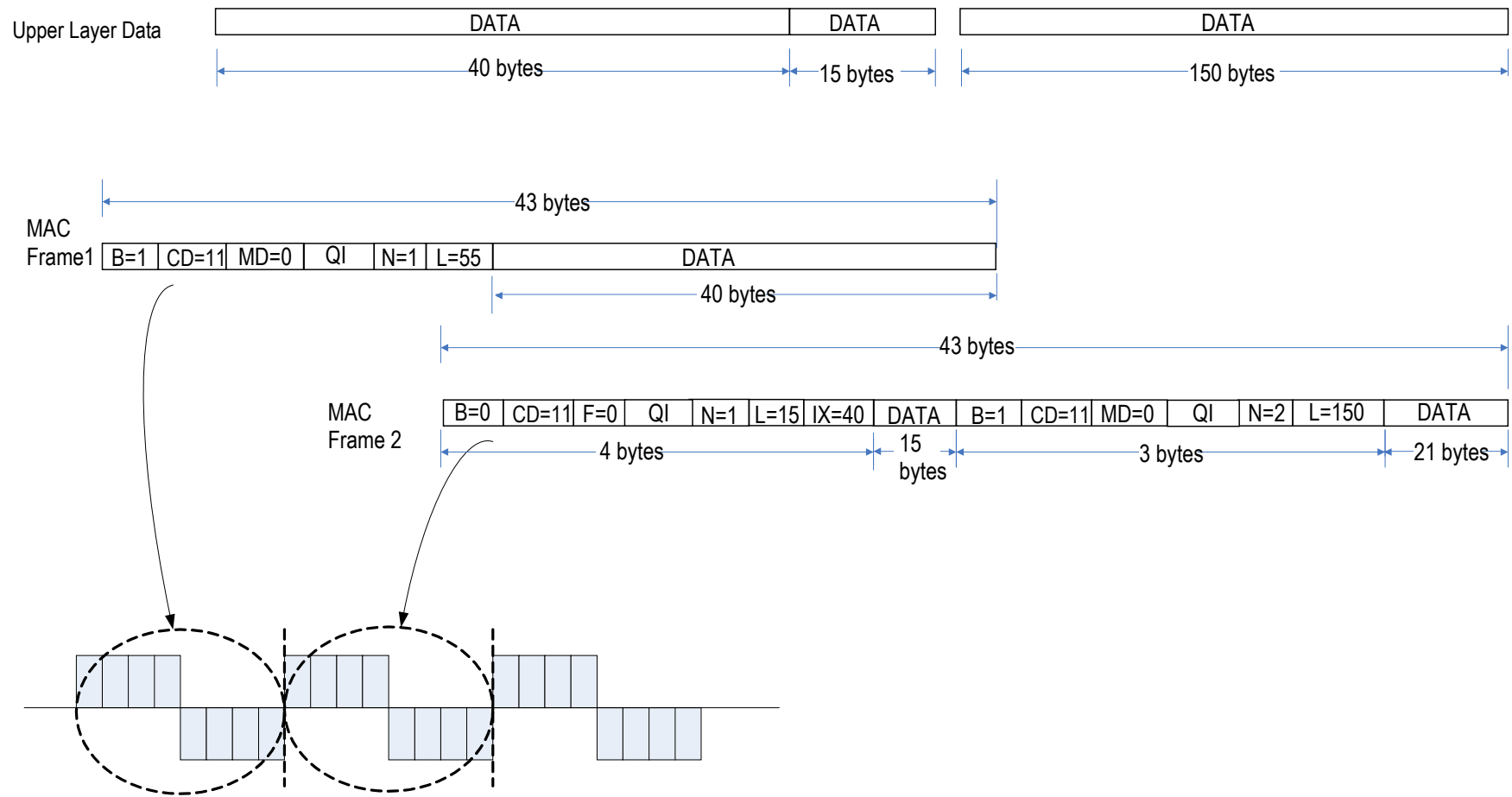

Figure 4.68 Example of MAC Frame Concatenation

4.4.4 MAC Control Layer

The relationship among the MAC control information, MAC frame and the PHY frame is shown in Figure 4.69. At the beginning of the MAC payload, protocol identifier and the message type are included. The other control information can be added in the remaining fields.

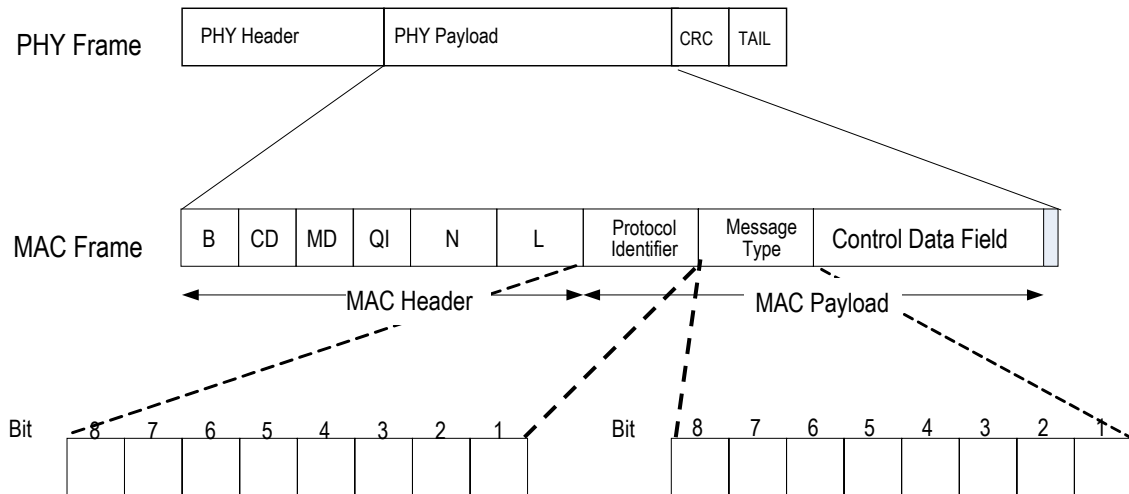

Figure 4.69 Relation among MAC Control Information, MAC Frame and PHY Frame

The MAC control and the access establishment phase control are performed by exchanging the messages in the MAC frame, which are described in this chapter. MAC control messages always include the protocol identifier and the message type. Other information elements can be added in time of need. Table 4.26 shows the protocol identifier that is used in the MAC layer.

Table 4.26 Protocol Identifier

Control Type	Protocol Identifier								
	Bit	8	7	6	5	4	3	2	1
MAC Control		0	0	0	0	0	0	0	1
Access Establishment Phase Control		0	0	0	0	0	0	1	0

4.4.4.1 MAC Control Protocol

MAC control signals are defined in this section. The state of the reception side is informed to transmission side by transmitting the message described in this section.

The message provides MAC control signal in this paragraph. Because it is control information, CD of the MAC header is 00 or 01. Table 4.27 shows the list of the MAC control protocol messages.

Table 4.27 MAC Control Protocol Message List

Message Name	Message Type								
	Bit	8	7	6	5	4	3	2	1
RR	P	0	0	0	0	0	0	0	1
RNR	P	0	0	0	0	0	0	1	0
SREJ		0	0	0	0	0	1	0	1
REJ		0	0	0	0	0	1	1	1
FRMR		0	0	0	0	0	1	0	0

4.4.4.1.1 Receive Ready (RR)

This message is used for reception confirmation of the received data and for the reception side to receive new data. This message includes sequence number N(R) that is to be received as N+1. Sequence number N(S), which indicates a sequence number that is to be sent, may be added to RR. When message length is 4 octets, it includes N(S).

RR has P (Poll) bit in its second octet. When transmission side requests RR to reception side as a reception confirmation, P=1 must be set. RR with P=1 should not be sent until RR with P=0 reception or T1 timer timeout. See section 4.4.4.2.3.1 for more details.

Figure 4.70 shows the RR message format.

Bit	8	7	6	5	4	3	2	1	
	Protocol Identifier: MAC Control Protocol								
	0	0	0	0	0	0	0	1	Octet 1
	Message Type: RR								
	P	0	0	0	0	0	0	1	Octet 2
	Sequence Number N(R)								Octet 3
	Sequence Number N(S)								Octet 4

Figure 4.70 RR Message Format

4.4.4.1.2 Receive Not Ready (RNR)

When the reception side cannot receive any data temporarily, then the reception side will inform the following message. It is impossible to receive any data by using this message. Sequence number N(R), which indicates a sequence number that is to be received, should be added to RNR. When message length is 4 octets, it includes N(S).

RNR has P (Poll) bit in its second octet. RNR with P=1 is sent when a node which is in busy state confirms if RNR has reached to opposite node or not. Figure 4.71 shows the RNR message format.

Bit	8	7	6	5	4	3	2	1	
	Protocol Identifier: MAC Control Protocol								
	0	0	0	0	0	0	0	1	Octet 1
	Message Type: RNR								
	P	0	0	0	0	0	1	0	Octet 2
	Sequence Number N(R)								Octet 3
	Sequence Number N(S)								Octet 4

Figure 4.71 RNR Message Format

4.4.4.1.3 Frame Reject (FRMR)

Reception side notifies that the received frame is rejected because the reception side cannot receive the expected data. Figure 4.72 shows the FRMR message. Table 4.28 shows the list of rejected reasons.

Bit	8	7	6	5	4	3	2	1	
	Protocol Identifier: MAC Control Protocol								
	0	0	0	0	0	0	0	1	Octet 1
	Message Type: FRMR								
	0	0	0	0	0	1	0	0	Octet 2
	Reject Reason								Octet 3

Figure 4.72 FRMR Message Format

Table 4.28 Reject Reason List

Reject Reason	Bit	Reject Reason Field							
		8	7	6	5	4	3	2	1
Undefined Protocol Identifier		0	0	0	0	0	0	0	1
Undefined Message Type		0	0	0	0	0	0	1	0
Undefined CD Field		0	0	0	0	0	0	1	1
Incorrect Data Part Length(L)		0	0	0	0	0	1	0	0
Incorrect Index(IX)		0	0	0	0	0	1	0	1
Incorrect Sequence Number(N)		0	0	0	0	0	1	1	0
Over the limit of retransmission times		0	0	0	0	0	1	1	1
Other Error		1	1	1	1	1	1	1	1

4.4.4.1.4 Selective Reject (SREJ)

SREJ message is sent when retransmission is requested to specify the sequence number. Figure 4.73 shows the SREJ message.

Bit	8	7	6	5	4	3	2	1	
	Protocol Identifier: MAC Control Protocol								Octet 1
	0	0	0	0	0	0	0	1	
	Message Type: SREJ								Octet 2
	0	0	0	0	0	1	0	1	
	Sequence Number N(R)								Octet 3

Figure 4.73 SREJ Message Format

4.4.4.1.5 Reject (REJ)

This message is used to request the retransmission for the specified frame and the following frames after specified sequence number.

Figure 4.74 shows the REJ message.

Bit	8	7	6	5	4	3	2	1	
	Protocol Identifier: MAC Control Protocol								Octet 1
	0	0	0	0	0	0	0	1	
	Message Type: REJ								Octet 2
	0	0	0	0	0	1	1	1	
	Sequence Number N(R)								Octet 3

Figure 4.74 REJ Message Format

4.4.4.2 Control Operation Elements

4.4.4.2.1 Poll bit

RR and RNR have a poll bit (called "P bit"). The P bit provides the following function. P bit set at "1" is used by the data link layer entity to poll the response frame from its peer's data link layer entity.

4.4.4.2.2 Variables

4.4.4.2.2.1 The range of a sequence number and variable

The range of a sequence number and variable described in this section is from 0 to 255. The value wraps around within this range. Because sequence number N field in MAC header length is 8 bits, a sequence number is a modulo value of 256.

4.4.4.2.2.2 Send state variable V(S)

Data link layer entity has a send state variable V(S). V(S) indicates the sequence number that should be transmitted next. V(S) is increased by one for each numbered frame transmission. However, V(S) must not exceed the value of adding the maximum number of window size to V(A).

4.4.4.2.2.3 Acknowledge state variable V(A)

Data link layer entity has an acknowledge state variable V(A). V(A) indicates the sequence number that should be acknowledged next by its peer. (V(A)-1 is equal to N(S) of the numbered frame acknowledged last.) The value of V(A) is updated by the correct N(R) value acknowledged by the RR/RNR frame transmitted from its peer. The correct N(R) value is in the range of $V(A) \leq N(R) \leq V(S)$.

4.4.4.2.2.4 Send sequence number N(S)

Numbered frame have a send sequence number, N(S) indicates the sequence number of transmitted frame. N(S) is set to V(S) prior to transmission of numbered frame(s).

4.4.4.2.2.5 Receive state variable V(R)

The data link layer entity has a receive state variable V(R). V(R) indicates the sequence number of the numbered frame that should be received next. V(R) is set at the newest sequence number added by 1 which can be continuously received by starting from current V(R).

4.4.4.2.2.6 Receive sequence number N(R)

RR/RNR frames have receive sequence numbers for data frames that should be received next. Prior to RR/RNR frame transmission, N(R) is set so that it becomes equal to the newest V(R). N(R) indicates the data link layer entity which sent such N(R) correctly received all data frames having numbers up to N(R)-1.

4.4.4.2.3 Timers

4.4.4.2.3.1 Response acknowledge timer T1

T1 timer starts when RR/RNR frame with P=1 was received, and stops when receiving its response frame or REJ/SREJ frame. When the data link layer entity detects T1 timer's time-out retry out, it sends FRMR frame.

4.4.4.2.3.2 Response transfer timer T2

T2 timer is used to delay sending RR/RNR frame for receiving normal numbered frame. When T2 timer stopped and the data link layer entity receives numbered frame, it starts T2 timer. When T2 timer expires, the data link layer entity sends RR/RNR response frame with P=0. When T2 timer is active, although it receives numbered frame, T2 timer goes on. When it receives command frame with P=1, T2 timer is stopped.

4.4.4.2.3.3 Peer station busy supervisory timer T3

T3 is the timer to supervise the busy state of opposite side. When the data link layer entity receives RNR frame, T3 timer is started. When T3 timer expires, the data link layer entity send RR/RNR frame in order to check peer state. While T3 timer is in active, if the data link layer entity receives RNR frame then restarts T3 timer, if it receives RR frame then stops T3 timer.

4.4.4.2.3.4 Link alive check timer T4

Satisfying one or more following conditions, the data link layer entity starts T4 timer.

- No data to send
- Outstanding
- My station is busy and outstanding
- Receive RR/REJ/SREJ when the data link layer entity has no data to send

Satisfying one or more following conditions, the data link layer entity stops T4 timer.

- $V(S)$ equals to $N(R)$ in received RR frame
- Receive newer numbered frame except for retransmission
- Start T3 timer

When T4 time out occurs, the data link layer entity sends RR/RNR frames.

When the data link layer entity detects T4 timer's time-out retry out, it sends FRMR frame.

4.4.4.3 Access Establishment Phase Control Protocol

Refer to Chapter 7.

Chapter 5 Common Channel Specification

5.1 Overview

In this chapter, common channel (CCH) to apply to link establishment control is specified. The structure of PHY layer, logical common channel (LCCH) structural methods and control message format are clarified.

5.2 Common Channel (CCH)

CCH consists of BCCH, PCH, TCCH and SCCH as shown in Figure 5.1.

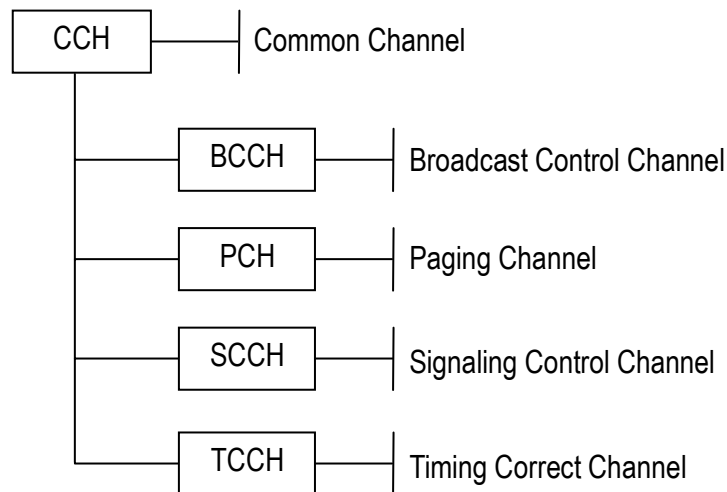

Figure 5.1 CCH Structure

The function of CCH is summarized in Table 5.1.

Table 5.1 Function Description of CCH

Channel Name	Direction	Function Description
BCCH	DL	BCCH is a DL channel to broadcast the control information from BS to MS.
PCH	DL	PCH is a DL channel to inform the paging information from BS to MS.
SCCH	Both	SCCH is both DL and UL channel for LCH assignment. DL SCCH notifies allocation of an individual channel to MS. And, UL SCCH requests LCH re-assignment to BS.
TCCH	UL	TCCH is an UL channel to detect UL transmission timing. Also, MS requires LCH establishment using TCCH.

Figure 5.2 shows the correspondence between PHY PRU and function channel in protocol phase.

PRU		Protocol Phase	Link Establishment Phase	
CCH	TCCH	TCCH	UL	
	CCCH	SCCH		DL
		BCCH PCH SCCH		

Figure 5.2 PRU, Protocol Phase and Functional Channel Correspondence

5.2.1 Logical Common Channel (LCCH)

Rules of the structure of logical common channel (LCCH) are shown in Figure 5.3.

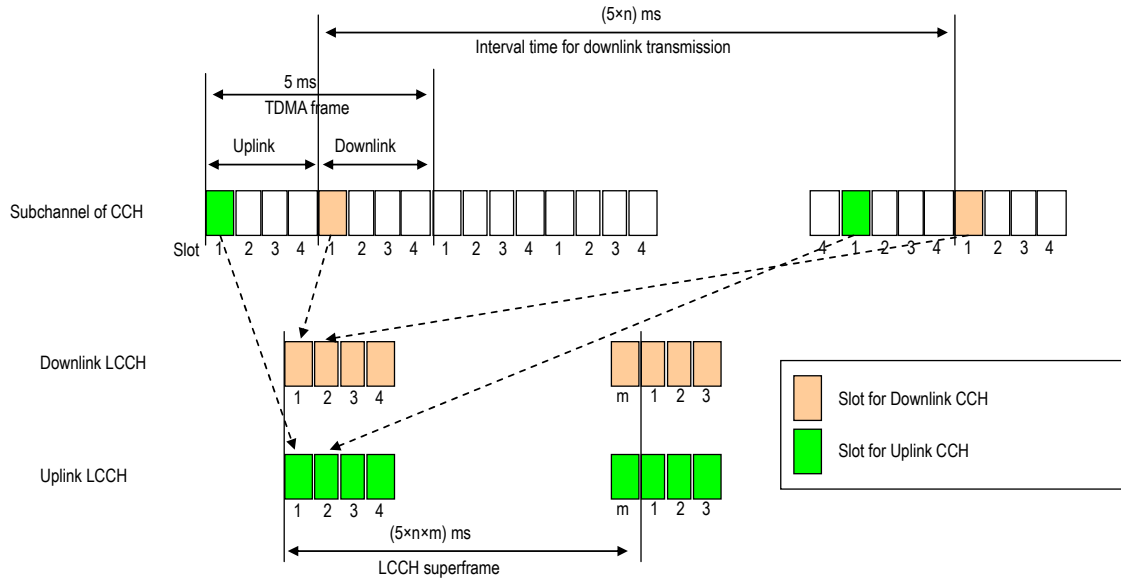

n is LCCH interval value. Refer to Section 5.2.3.1.

Figure 5.3 Slot and LCCH

LCCH has the superframe structure shown in Section 5.2.3. All transmission/reception timing of slots for controlling intermittent transmission and so forth is generated based on the superframe.

5.2.2 Definition of Superframe

The minimum cycle of the DL LCCH that specifies the slot position of all LCCH elements is specified as the LCCH superframe. As DL LCCH elements, there are three types of LCCH elements:

They are BCCH, which is used by the appropriate system, all PCH (P1-Pk: Number of groups = k) corresponding to the paging group as well as the SCCH with fixed insertion.

BCCH(A) must be transmitted by the lead slot of the LCCH superframe. The leading position of the superframe is reported via BCCH transmission. Also, BCCH(B) is defined by something other than the superframe lead.

5.2.3 Superframe Structure of DL LCCH

The superframe structure of the DL LCCH that is defined by profile data is informed to each MS on BCCH.

Depending on the way to select the profile data that defines the structure, the LCCH superframe can transmit the identical paging group (π_i : $i = 1$ to k) multiple times, but the number of continuous transmissions (provided by n_{BS}) for one paging call and the number of same paging groups n_{SG} included in the LCCH superframe are independent. Continuous transmission in response to one paging call can be concluded within the LCCH superframe, or it can be spread over several superframes.

If necessary, it is possible to temporarily replace LCCH elements except for BCCH (A), and send the other LCCH elements.

Otherwise, the frame basic unit must follow the rules below.

- (a) Within one frame basic unit, regularly intermittently transmitted BCCH or SCCH appears first, and PCH is established as the function channel that follows it.
- (b) Within one frame basic unit, if n_{PCH} data is greater than or equal to two, the respective PCHs are continuously established.

Further, during system operation, if profile data is modified, it is necessary to control information flow and contents so that all MSs can receive those modified contents.

Specific profile data are shown below.

5.2.3.1 LCCH Interval Value (n)

LCCH interval value shows the cycle in which BS intermittently transmits an LCCH slot. It is the value expressed by the number of TDMA frames (n) within the intermittent transmission cycle.

5.2.3.2 Frame Basic Unit Length (n_{SUB})

This stands for the length of the LCCH superframe, which constitutes consecutive elements of BCCH, SCCH and PCH. This LCCH superframe constituent element is called the frame basic unit.

5.2.3.3 Number of Same Paging Groups (n_{SG})

This stands for the number of times that the same paging group is repeatedly transmitted in one superframe.

5.2.3.4 PCH Number (n_{PCH})

This stands for the number of PCH signal elements in a frame basic unit.

5.2.3.5 Paging Grouping Factor (n_{GROUP})

This stands for the number of frame basic units required for one transmission of each PCH belonging to all paging groups in one superframe.

Furthermore the multiple (n_{GROUP}) of the number of PCHs (n_{PCH}) is specified as the group division number of PCH information.

However, when the PCH paging groups are mutually related as two LCCH are used, number of group division is calculated as $n_{GROUP} \times n_{PCH} \times 2$.

5.2.3.6 Battery Saving Cycle Maximum value (n_{BS})

n_{BS} stands for the number of times that BS continuously transmits the identical reception signal to a certain paging group. The maximum battery saving cycles of MS that are permitted by the system depending on n_{BS} are specified.

(Maximum battery saving cycle = $5 \text{ ms} \times n \times n_{SUB} \times n_{GROUP} \times n_{BS}$)

5.2.3.7 The Relationship Among Profile Data

The relationship among profile data are shown below.

$$n_{SUB} \geq n_{PCH} + 1$$

In the frame basic unit, $n_{PCH} + 1$ is the lowest frame basic unit length because BCCH is always assigned.

$$N = n_{SG} \times n_{GROUP}$$

The number of frame basic units N within an LCCH superframe is given by the product of the number of the same paging groups n_{SG} and the paging grouping factor n_{GROUP} .

(Units are frame basic units)

$$n_{FRM} \leq (\geq) n_{GROUP} \times n_{BS}$$

If the number of the same paging groups n_{SG} in the LCCH superframe is the same as the battery saving cycle maximum value n_{BS} , there will be an equal sign. In other cases, there will not be an equal sign.

Left side: Number of frame basic units in LCCH superframe

Right side: Maximum battery saving cycle

(The unit is referred to as the frame basic unit.)

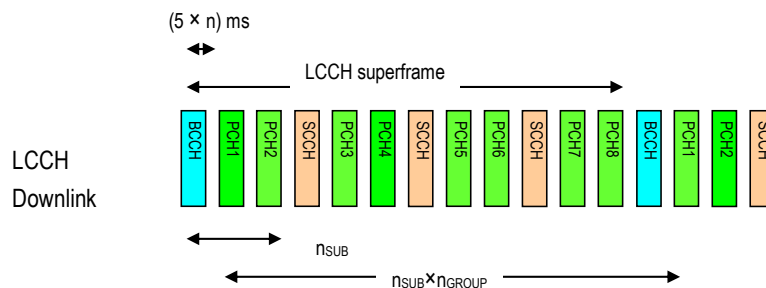

- The diagram above shows an example in which $n_{SG}=1$, $n_{SUB}=3$, $n_{PCH}=2$, $n_{GROUP}=4$

Figure 5.4 An Example of LCCH Structure

5.2.3.8 Paging Group Calculation Rules

From the information on Paging ID and BCCH, PCH which should be received is computable with the following formula. Refer to Section 5.5.3 for Paging ID.

[Paging Group formula]

$$\text{Paging Group} = (\text{Paging ID}) \text{ MOD } (n_{PCH} \times n_{GROUP}) + 1$$

Paging ID : Identification information for paging

n_{PCH} : Number of PCHs in the frame basic unit

n_{GROUP} : Paging grouping factor

5.2.3.9 Intermittent Transmission Timing for ICH

Figure 5.5 shows the intermittent transmission timing of ICH according to the ICH offset and the ICH period. ICH offset indicates the beginning frame of ICH based on the CCH frame. ICH period indicates the cycle of ICH based on the beginning frame by ICH offset. However, the intermittent transmission timing of ICH must always be adjusted according to the beginning frame of ICH based on the CCH frame.

Refer to Section 5.5.4.1.3 for information elements of the ICH offset and the ICH period.

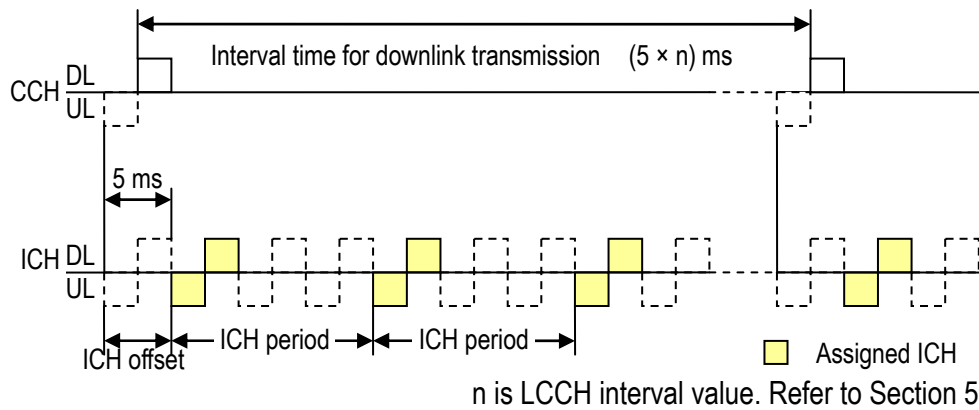

Figure 5.5 Intermittent Transmission Timing for ICH

5.2.4 Structure of UL LCCH

The UL LCCH is sent from each MS only when needed. It is used as the UL slot 2.5 ms before the DL LCCH. Refer to Figure 5.3.

5.2.5 Structure of DL LCCH

A standard structural example of the DL LCCH is shown in Figure 5.6.

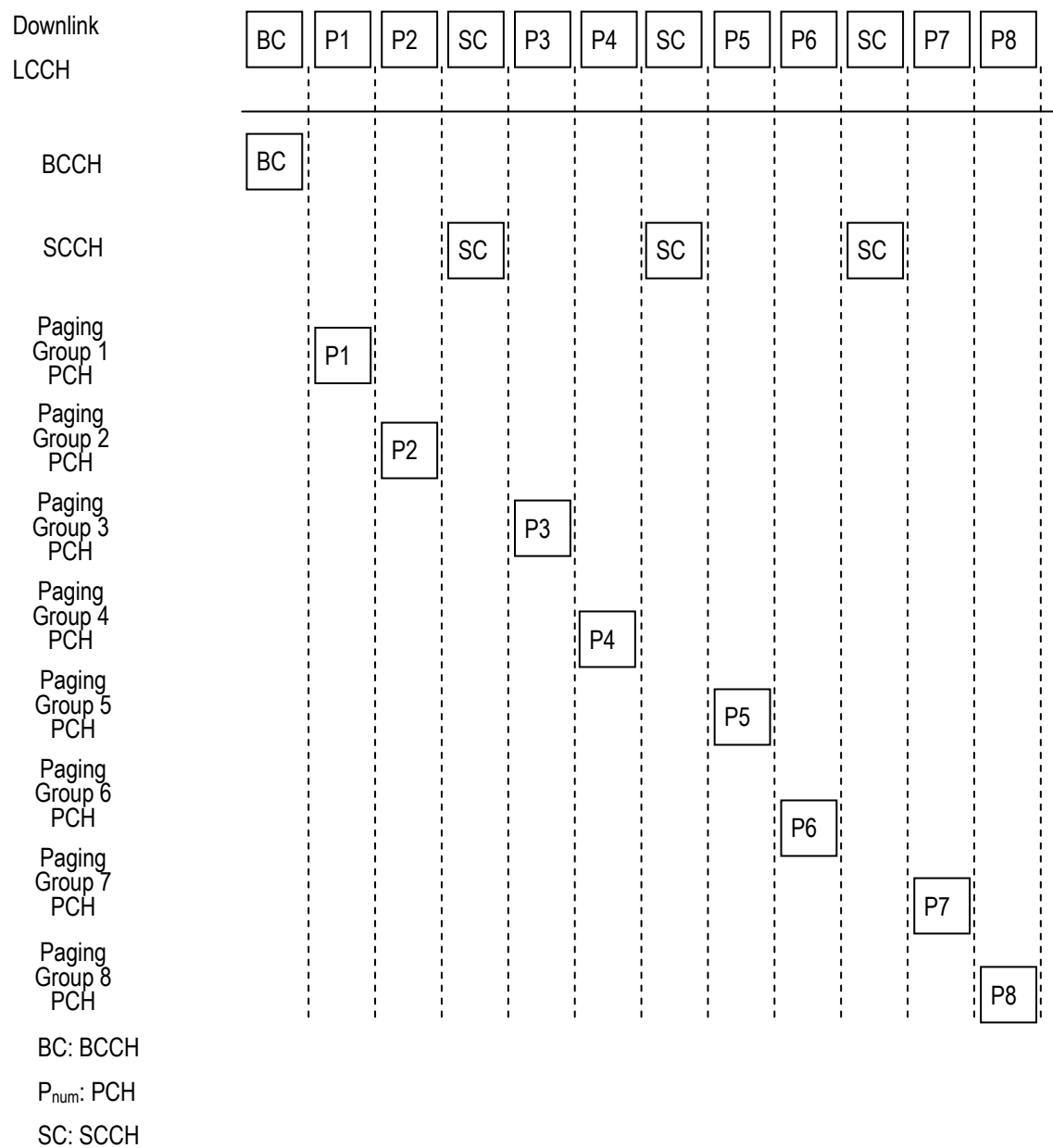

Figure 5.6 Structural Example of DL LCCH

5.2.6 LCCH Multiplexing

BS can multiply LCCHs within the scope of the physical slot transmission condition. In this case, MS can receive at least one logical common channel transmission from BS. Shown here is a standard structural example that uses two DL LCCHs.

5.2.6.1 When PCH Paging Groups Being Independent

The PCH paging group of the LCCHs f1 and f2 are mutually independent, but each DL LCCH superframe structure is identical. Refer to Section 5.5.2.1 for $n1_{offset}$ and n_{offset} .

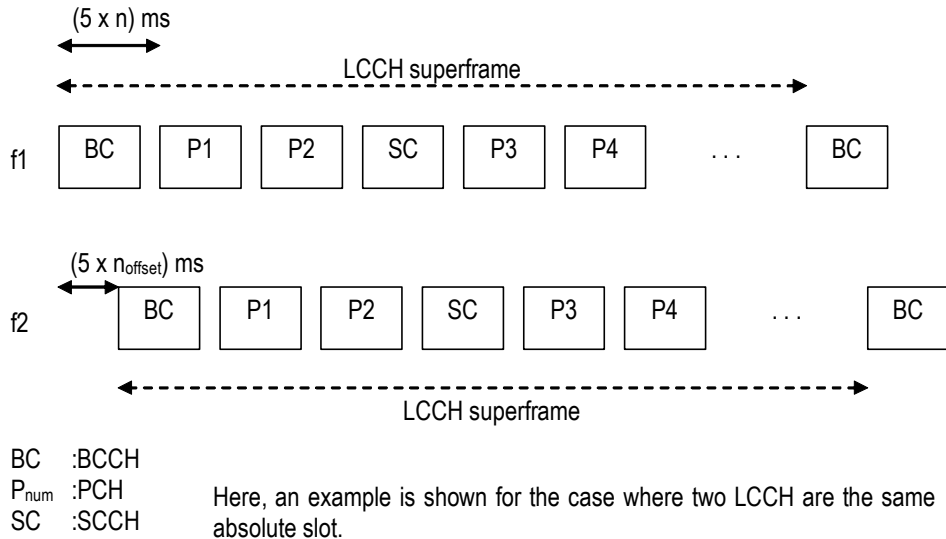

Figure 5.7 Example of Multiplex for Independent LCCH

5.2.6.2 When PCH Paging Groups Being Inter-related

LCCH f1's PCH transmits odd-numbered groups, and f2 transmits even-numbered groups.

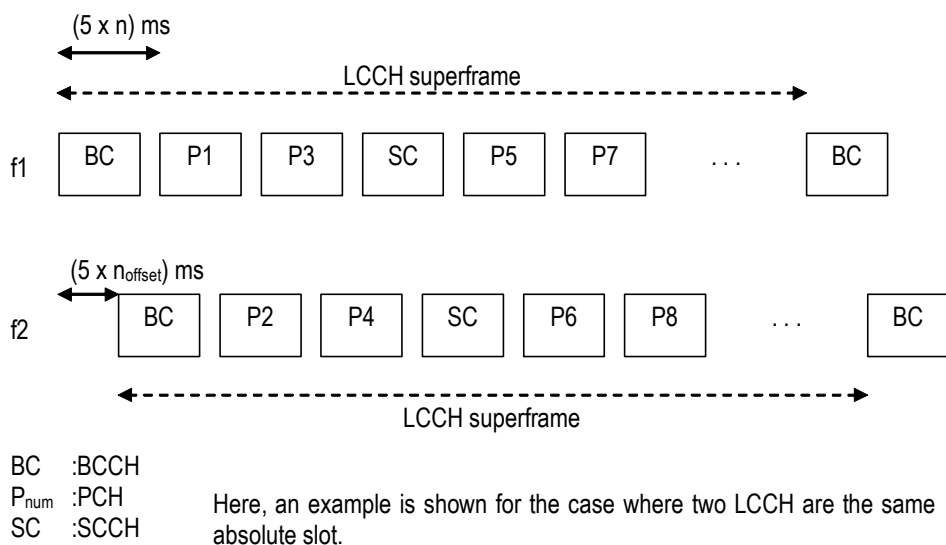

Figure 5.8 Example of Multiplex for Inter-related LCCH

5.3 PHY Frame Format

The PHY frame formats for CCH are shown in Figure 5.9 to Figure 5.14.

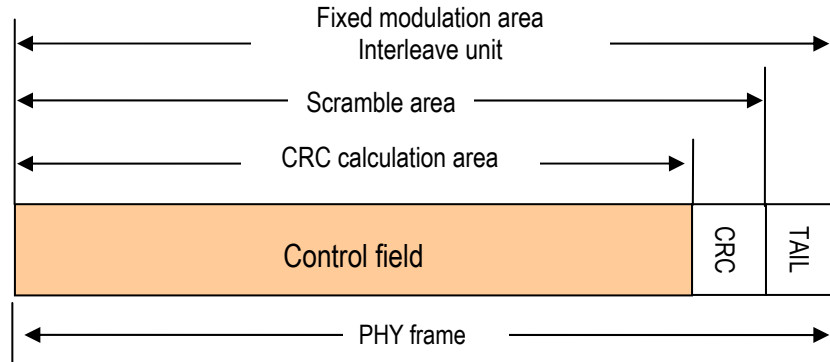

Figure 5.9 PHY Frame Format for CCH

Figure 5.9 shows that the modulation and the CRC calculation are of PHY format for CCH. CCH uses the fixed Modulation. Modulation method is BPSK for OFDMA and $\pi / 2$ - BPSK for SC, while the coding rate is 1/2. Interleaving process is done in the entire fixed modulation area. CRC of the control field is calculated. After CRC addition, the scramble is done from the control field to CRC. Initial value of scramble is all set as 1.

5.3.1 BCCH

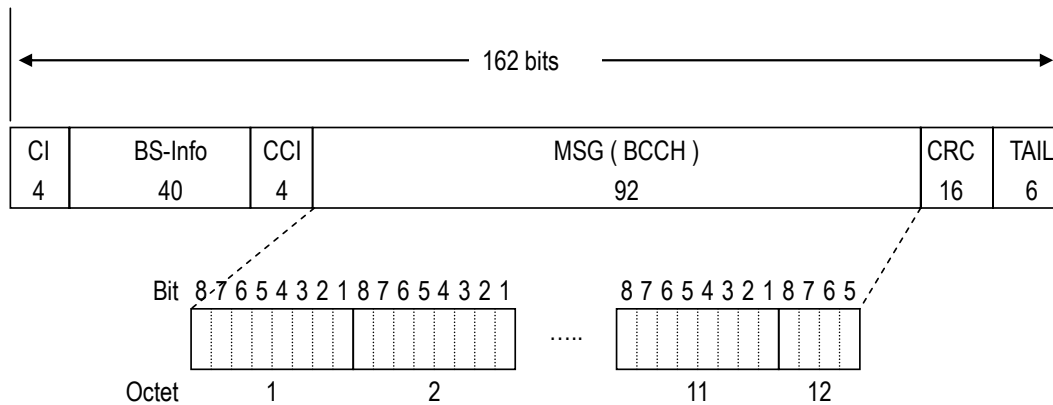

Figure 5.10 BCCH Format

5.3.2 PCH

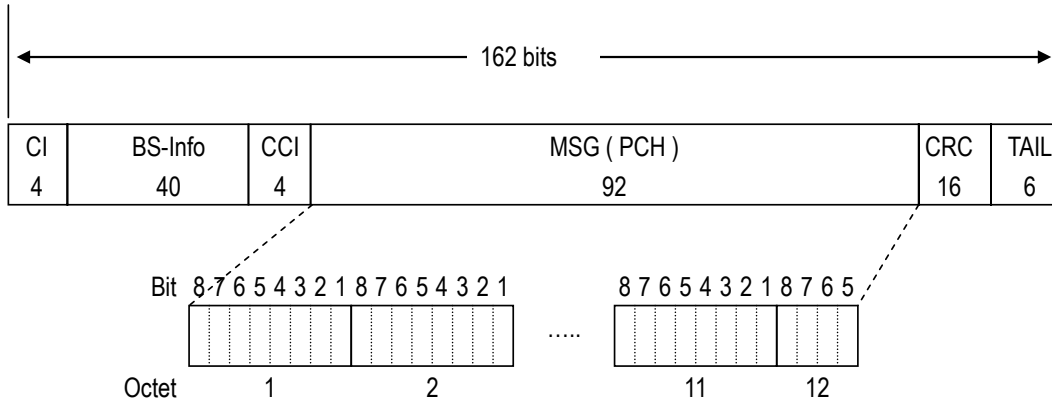

Figure 5.11 PCH Format

5.3.3 TCCH

TCCH is a signal pattern. It is defined as timing correct channel at Sections 3.5.6 and 3.6.5.

5.3.4 SCCH

5.3.4.1 DL SCCH

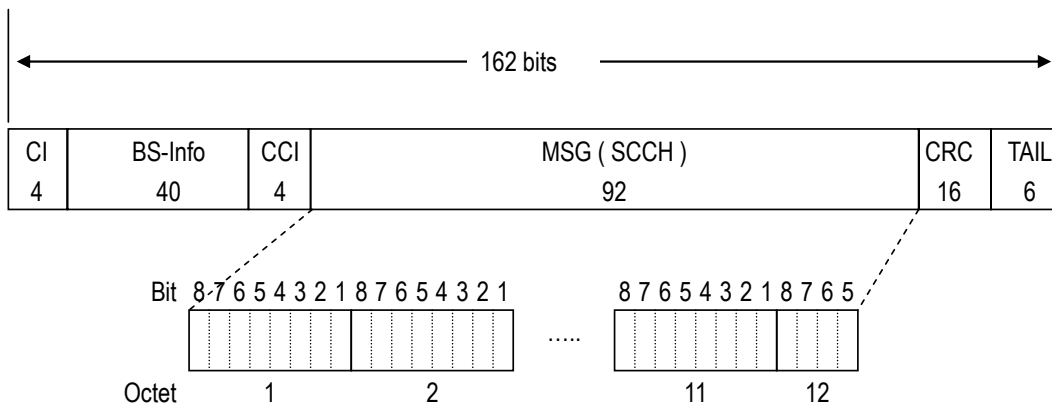

Figure 5.12 DL SCCH Format

5.3.4.2 UL SCCH for OFDMA

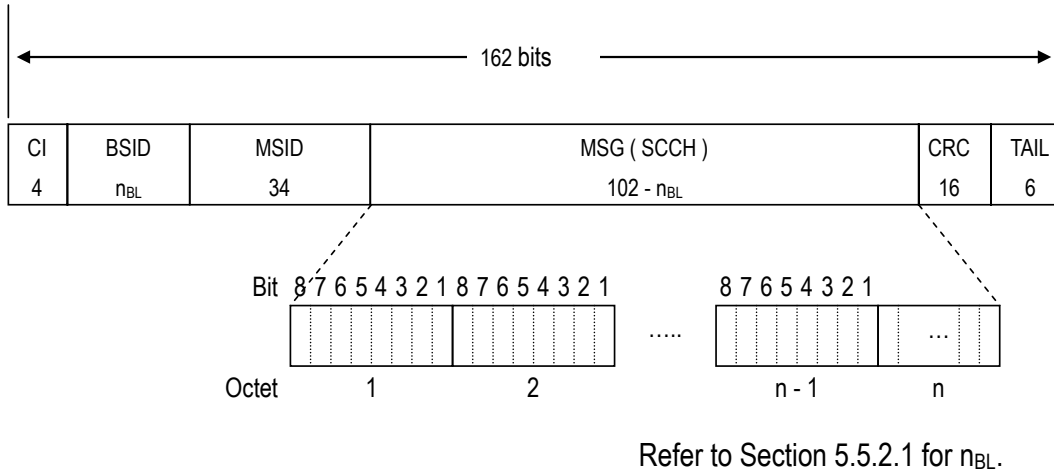

Figure 5.13 UL SCCH Format for OFDMA

5.3.4.3 UL SCCH for SC

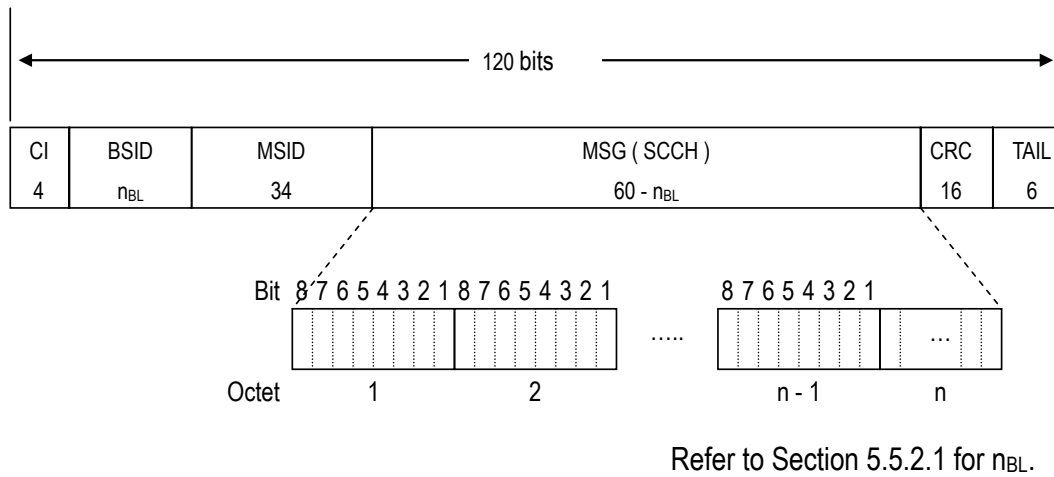

Figure 5.14 UL SCCH Format for SC (without virtual GI extension)

5.4 Control Field Format

5.4.1 Channel Identifier (CI)

CI coding rules are shown in Table 5.2 and Table 5.3.

Table 5.2 CI Coding for DL CCH

Bit				
4	3	2	1	
0	0	1	1	BCCH (B)
0	1	0	0	BCCH (A)
1	0	0	1	SCCH
1	0	1	1	PCH
Other				Reserved

Table 5.3 CI Coding for UL CCH

Bit				
4	3	2	1	
1	0	1	0	SCCH
Other				Reserved

5.4.2 BS Information (BS-Info)

BS-Info must be composed according to the format shown in Figure 5.15.

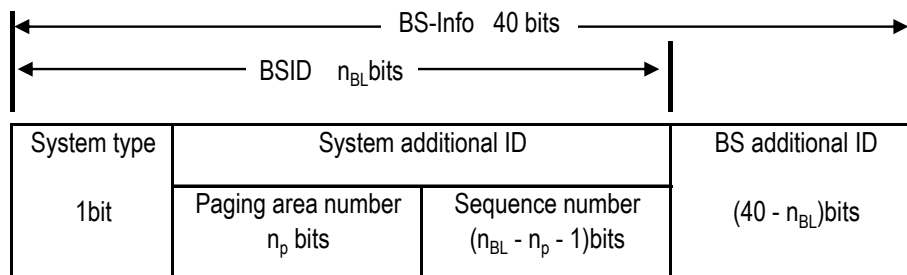

Refer to Section 5.5.2.1 for n_{BL} and n_p.

Figure 5.15 BS-Info Format

BS-Info is composed of BSID and BS additional ID. BSID is defined for individual ID of BS.

5.4.2.1 Base Station ID (BSID)

The area of BSID is indicated in the BSID area bit length (n_{BL}) as "radio channel information broadcasting" message on BCCH. The following information elements are included in BSID.

5.4.2.1.1 System Type

The system type is indicated in private system.

Table 5.4 System Type

Bit	
1	
0	Private system
1	Reserved

5.4.2.1.2 System Additional ID

The system additional ID is composed of the paging area number and the sequence number. The area of paging area number is indicated in the paging area number length (n_p) as "radio channel information broadcasting" message on BCCH.

5.4.2.1.2.1 Paging Area Number

Paging area is identified by paging area number.

5.4.2.1.2.2 Sequence Number

BS is identified by sequence number.

5.4.2.2 BS Additional ID

BS additional ID is an area to notify of the function of each BS.

5.4.3 Common Control Information (CCI)

CCI is composed of the absolute slot number.

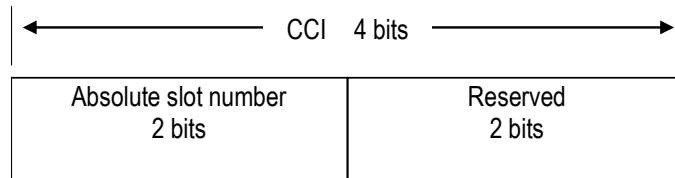

Figure 5.16 CCI Format

5.4.3.1 Absolute Slot Number

Absolute slot number indicates the number of the slot which the BS sends CCH in.

Table 5.5 Absolute Slot Number

Bit		
2	1	
0	0	1st TDMA slot for DL.
0	1	2nd TDMA slot for DL.
1	0	3rd TDMA slot for DL.
1	1	4th TDMA slot for DL.

5.4.4 Mobile Station ID (MSID)

The length of MSID is 34 bits.

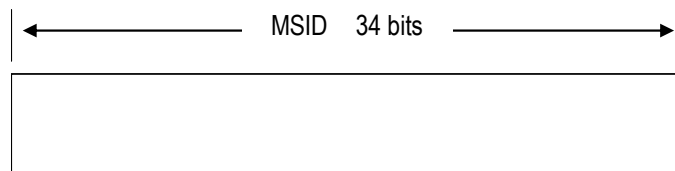

Figure 5.17 MSID Format

5.5 MSG Field

5.5.1 Message Type List

A list of messages defined in the MSG field is shown in Table 5.6.

Table 5.6 Message for MSG Field

Message for MSG (BCCH)	Reference
"Radio channel information broadcasting" message	5.5.2.1
"System information broadcasting" message	5.5.2.2
"Optional information broadcasting" message	5.5.2.3
Message for MSG (PCH)	Reference
"No Paging" message	5.5.3.1
"Paging type 1" message	5.5.3.2
"Paging type 2" message	5.5.3.3
"Paging type 3" message	5.5.3.4
"Paging type 4" message	5.5.3.5
"Paging type 5" message	5.5.3.6
"Paging type 6" message	5.5.3.7
"Paging type 7" message	5.5.3.8
Message for MSG (SCCH)	Reference
"Idle" message	5.5.4.1.1
"LCH assignment 1" message	5.5.4.1.2
"LCH assignment 2" message	5.5.4.1.3
"LCH assignment 3" message	5.5.4.1.4
"LCH assignment standby" message	5.5.4.1.5
"LCH assignment reject" message	5.5.4.1.6
"LCH assignment re-request" message	5.5.4.2.1

5.5.2 MSG (BCCH)

The format of message type for BCCH is shown in Table 5.7, and the coding is shown in Table 5.8.

Table 5.7 Format of Message Type for BCCH

Octet \ Bit	8	7	6	5	4	3	2	1
1	Message type				Reserved			

Table 5.8 Message Type Coding for BCCH

Bit	8	7	6	5	
0	0	0	0	1	"Radio channel information broadcasting" message
0	0	0	1	0	"System information broadcasting" message
0	0	1	1		"Optional information broadcasting" message
	Other				Reserved

5.5.2.1 "Radio Channel Information Broadcasting" Message

BS must broadcast the radio channel structure information to MS using this message. The message format is shown in Table 5.9, and the information element explanations are shown in Table 5.10. Refer to Section 5.2.3 for the relationship between the information elements of this message and the superframe.

Table 5.9 "Radio Channel Information Broadcasting" Message

Message type : "Radio channel information broadcasting" message
 Direction : BS → MS (DL)
 Function channel : BCCH

Octet \ Bit	8	7	6	5	4	3	2	1
1	0 0 0 1 Message Type				Reserved			
2	Reserved		LCCH Interval Value n					
3	Paging Grouping Factor n_{GROUP}				Paging Area Number Length n_p			
4	Odd / Even ID	Re-served	Number of Same Paging Groups n_{SG}		Battery Saving Cycle Maximum Value n_{BS}			
5	Control Carrier Structure		PCH Number n_{PCH}		Frame Basic Unit Length n_{SUB}			
6	n_{offset}		$n1_{offset}$					
7	Re-served	Broadcasting Status Indication			Global Definition Information Pattern			
8	Protocol Version							
9	Reserved			BSID Area Bit Length n_{BL}				
10	Reserved							
11								
12								

Table 5.10 Information Elements in "Radio Channel Information Broadcasting" Message

LCCH Interval Value n (Octet 2)

It shows the DL LCCH slot intermittent cycle.

Bit	6	5	4	3	2	1	
0	0	0	0	0	0	0	Reserved
0	0	0	0	0	0	1	n = 1
0	0	0	0	0	1	0	n = 2
0	0	0	0	0	1	1	n = 3
			:				:
0	1	0	1	0	0		n = 20
			:				:
1	1	1	1	1	1	1	n = 63

Paging Grouping Factor n_{GROUP} (Octet 3)

It shows the value of PCH information corresponding to the number of group divisions.

Bit	8	7	6	5	
0	0	0	0	0	LCCH superframe is not constructed (optional)
0	0	0	0	1	$n_{\text{GROUP}} = 1$
0	0	0	1	1	$n_{\text{GROUP}} = 2$
		:			:
1	1	1	1	1	$n_{\text{GROUP}} = 15$

(Note) If LCCH is multiplexed, the values of n_{PCH} and n_{GROUP} will be set so that the paging group number does not exceed 127.

Paging Area Number Length n_p (Octet 3)

It shows the bit length of the paging area number included in the BSID.

Refer to Section 5.4.2 for composition of BSID.

Bit	4	3	2	1	
0	0	0	0	0	Reserved
0	0	0	0	1	$n_p = 4$
0	0	0	1	0	$n_p = 6$
0	0	0	1	1	$n_p = 8$
0	1	0	0	0	$n_p = 10$
0	1	0	0	1	$n_p = 12$
0	1	0	1	0	$n_p = 13$
0	1	0	1	1	$n_p = 14$
1	0	0	0	0	$n_p = 15$
1	0	0	0	1	$n_p = 16$
1	0	0	1	0	$n_p = 17$
1	0	0	1	1	$n_p = 18$
1	1	0	0	0	$n_p = 19$
1	1	0	0	1	$n_p = 20$
1	1	0	1	0	$n_p = 21$
1	1	0	1	1	$n_p = 22$

(Note), n_p must be the same even in a different paging area if handover between paging areas is executed.

Odd / Even ID (Octet 4)

(a) This information element has the following meanings when (1 0) (shows that there is a mutual relationship between PCH paging group) is set in the control carrier structure (Octet 5) information element contained in "radio channel information broadcasting" message:

Bit	
8	
0	It shows LCCH which transmits even-numbered paging group.
1	It shows LCCH which transmits odd-numbered paging group.

(b) In other cases than stated above, it has the following meanings:

Bit	
8	
0	Reserved
1	Reserved

Number of Same Paging Groups n_{SG} (Octet 4)

It shows the number of PCH slots belonging to the same paging group in the LCCH superframe.

Bit	6	5	4	
0	0	0	0	LCCH superframe is not constructed (optional)
0	0	0	1	$n_{SG} = 1$
		:	:	
1	1	1	1	$n_{SG} = 7$

Battery Saving Cycle Maximum Value n_{BS} (Octet 4)

It shows the times BS continuously sends the same paging signal to the paging group.

Bit	3	2	1	
0	0	0	0	LCCH superframe is not constructed (optional)
0	0	0	1	$n_{BS} = 1$
		:	:	
1	1	1	1	$n_{BS} = 7$

Control Carrier Structure (Octet 5)

It shows the presence or absence of a mutual relationship between paging group and number of LCCHs used by the relevant BS.

Bit		
8	7	
0	0	Shows that only 1 LCCH is used.
0	1	Shows that 2 LCCHs are used, and each individual LCCH is independent.
1	0	Shows that 2 LCCHs are used, and PCH paging groups are mutually related.
1	1	Reserved

PCH Number n_{PCH} (Octet 5)

It shows the number of PCHs in the frame basic unit.

Bit			
6	5	4	
0	0	0	No PCH (optional)
0	0	1	1 PCH slots in frame basic unit ($n_{PCH} = 1$)
	:	:	:
1	1	1	7 PCH slots in frame basic unit ($n_{PCH} = 7$)

(Note) If LCCH is multiplexed, the values of n_{PCH} and n_{GROUP} will be set so that the paging group number does not exceed 127.

Frame Basic Unit Length n_{SUB} (Octet 5)

It shows the length of the LCCH superframe structural element (frame basic unit).

Bit			
3	2	1	
0	0	0	(Optional)
0	0	1	$n_{SUB} = 1$
	:	:	:
1	1	1	$n_{SUB} = 7$

n_{offset} (Octet 6)

When the value of control carrier structure is (0 1) or (1 0), this information element shows that the other control slot has transmitted in one of the absolute slot numbers 1, 2, 3, or 4.

Bit		
8	7	
0	0	It shows that the absolute slot number is the 1st slot position for DL.
0	1	It shows that the absolute slot number is the 2nd slot position for DL.
1	0	It shows that the absolute slot number is the 3rd slot position for DL.
1	1	It shows that the absolute slot number is the 4th slot position for DL.

(Note) The time from the local control slot to the other control slot is given by the following equation.

$$\Delta t \text{ ms} = 5 \times n_{1\text{offset}} + 0.625 \times (\text{absolute slot number of other control slot} - \text{absolute slot number of local control slot})$$

n_{1offset} (Octet 6)

When the value of control carrier structure is (0 1) or (1 0), this information element shows that the other control slot has conducted transmission in the TDMA frame after $5 \times n_{1\text{offset}}$ ms.

Bit						
6	5	4	3	2	1	
0	0	0	0	0	0	n _{1offset} = 0
0	0	0	0	0	1	n _{1offset} = 1
0	0	0	0	1	0	n _{1offset} = 2
0	0	0	0	1	1	n _{1offset} = 3
			:			:
1	1	1	1	1	1	n _{1offset} = 63

(Note) The time from the local control slot to the other control slot is given by the following equation.

$$\Delta t \text{ ms} = 5 \times n_{1\text{offset}} + 0.625 \times (\text{absolute slot number of other control slot} - \text{absolute slot number of local control slot})$$

Broadcasting Status Indication (Octet 7)

It shows the presence or absence of information broadcasting messages other than "radio channel information broadcasting" message sent on the relevant LCCH.

Bit			
7	6	5	
-	-	1/0	"System information broadcasting" message present / absent
-	1/0	-	"Optional information broadcasting" message present / absent
1/0	-	-	Reserved

Global Definition Information Pattern (Octet 7)

It shows the relevant pattern number of the present "radio channel information broadcasting" message. When "radio channel information broadcasting" message changes, the new global definition information pattern is set.

Bit				
4	3	2	1	
0	0	0	0	Global definition information pattern (0)
0	0	1	0	Global definition information pattern (1)
0	1	0	0	Global definition information pattern (2)
		:		:
1	1	1	0	Global definition information pattern (7)
	Other			Reserved

Protocol Version (Octet 8)

It shows protocol version supported by BS.

Bit								
8	7	6	5	4	3	2	1	
-	-	-	-	-	-	-	1/0	Version 1 present / absent
			Other				-	Reserved

BSID Area Bit Length n_{BL} (Octet 9)

It shows the BSID area bit length included in the BS information.
Refer to Section 5.4.2.

Bit					
5	4	3	2	1	
0	0	0	0	0	$n_{BL} = 15$
0	0	0	0	1	$n_{BL} = 16$
0	0	0	1	0	$n_{BL} = 17$
		:			:
1	1	0	0	1	$n_{BL} = 40$
	Other				Reserved

5.5.2.2 "System Information Broadcasting" Message

BS can broadcast system information to MS using this message. The message format is shown in Table 5.11 and explanation of elements is shown in Table 5.12.

Table 5.11 "System Information Broadcasting" Message

Message type : "System information broadcasting" message
 Direction : BS → MS (DL)
 Function channel : BCCH

Octet \ Bit	8	7	6	5	4	3	2	1
1	0	0	1	0	Reserved			
	Message Type							
2	Reserved							Restriction Indication
3	Restriction Class							
4								
5	Reserved							
6								
7								
8								
9								
10								
11					Broadcasting Message Status Number m_{sys}			
12	Broadcasting Reception Indication							

Table 5.12 Information Elements in "System Information Broadcasting" Message

Restriction Indication (Octet 2)

It is used to indicate if this message includes restriction information.

Bit	
1	
0	This message does not include restriction information.
1	This message includes restriction information.

Restriction Class (Octet 3-4)

It shows the restriction class number equal to the last digit in decimal digits of MSID. It is a priority class from class 10 to Class 15 over others. MS shall NOT start both outgoing call and incoming call while indicated restriction from BS, except handover and location registration.

Octet 3

Bit									
8	7	6	5	4	3	2	1		
-	-	-	-	-	-	-	0/1		Class 0 no restriction/restriction
-	-	-	-	-	-	0/1	-		Class 1 no restriction/restriction
-	-	-	-	-	0/1	-	-		Class 2 no restriction/restriction
-	-	-	-	0/1	-	-	-		Class 3 no restriction/restriction
			:						
0/1	-	-	-	-	-	-	-		Class 7 no restriction/restriction

Octet 4

Bit									
8	7	6	5	4	3	2	1		
-	-	-	-	-	-	-	0/1		Class 8 no restriction/restriction
-	-	-	-	-	-	0/1	-		Class 9 no restriction/restriction
-	-	-	-	-	0/1	-	-		Class 10 no restriction/restriction (Reserved)
-	-	-	-	0/1	-	-	-		Class 11 no restriction/restriction
-	-	-	0/1	-	-	-	-		Class 12 no restriction/restriction (Reserved)
			:						(Reserved)
0/1	-	-	-	-	-	-	-		Class 15 no restriction/restriction (Reserved)

Restriction start condition

- (1) System Information Broadcasting Message is transmitted and
- (2) System Information Broadcasting Message/Restriction Indication=1 and
- (3) The class of System Information Broadcasting Message/Restriction Class=1 corresponds MS class

Restriction clear condition

- (1) No reception System Information Broadcasting Message between two times reception of Global Definition Information Pattern or

- (2) System Information Broadcasting Message/Restriction Indication=0 or
- (3) The class of System Information Broadcasting Message/Restriction Class=0 corresponds MS class

Broadcasting Message Status Number m_{sys} (Octet 11)

It shows the status number of the present "system information broadcasting" message. This element can be used arbitrarily, but when the status changes, the new status is set.

Bit			
3	2	1	
0	0	0	$m_{sys} = 0$
0	0	1	$m_{sys} = 1$
0	1	0	$m_{sys} = 2$
	⋮		⋮
1	1	1	$m_{sys} = 7$

Broadcasting Reception Indication (Octet 12)

It shows global definition information pattern or local information broadcasting reception indication of broadcasting information message other than "radio channel information broadcasting" message. Refer to Section 5.5.2.1 for global definition information pattern.

Bit				
8	7	6	5	
-	-	-	0	<u>Global definition information pattern indication</u>
0	0	0	0	Global definition information pattern (0)
0	0	1	0	Global definition information pattern (1)
	⋮			⋮
1	1	1	0	Global definition information pattern (7)
-	-	-	1	<u>Local information broadcasting reception indication</u>
0	0	0	1	"System information broadcasting" message reception indication
0	0	1	1	"Optional information broadcasting" message reception indication
	Other			Reserved

5.5.2.3 "Optional Information Broadcasting" Message

BS can broadcast optional information to MS using this message. The message format is shown in Table 5.13 and explanation of elements is shown in Table 5.14.

Table 5.13 "Optional Information Broadcasting" Message

Message type : "Optional information broadcasting" message
 Direction : BS → MS (DL)
 Function channel : BCCH

Octet \ Bit	8	7	6	5	4	3	2	1
1	0	0	1	1	Reserved			
2	Reserved							
3								
4								
5								
6								
7								
8								
9								
10								
11								
12	Broadcasting Reception Indication							

Table 5.14 Information Elements in "Optional Information Broadcasting" Message

Broadcasting Message Status Number m_{opt} (Octet 11)

It shows the status number of the present "system information broadcasting" message. This element can be used arbitrarily, but when the status changes, the new status is set.

Bit	3	2	1	
0	0	0	0	$m_{opt} = 0$
0	0	1	1	$m_{opt} = 1$
0	1	0	0	$m_{opt} = 2$
		:		:
1	1	1	1	$m_{opt} = 7$

Broadcasting Reception Indication (Octet 12)

It shows global definition information pattern or local information broadcasting reception indication of broadcasting information message other than "radio channel information broadcasting" message. Refer to Section 5.5.2.1 for global definition information pattern.

Bit	8	7	6	5	
-	-	-	-	0	<u>Global definition information pattern indication</u>
0	0	0	0	0	Global definition information pattern (0)
0	0	1	0	0	Global definition information pattern (1)
		:			:
1	1	1	1	0	Global definition information pattern (7)
-	-	-	-	1	<u>Local information broadcasting reception indication</u>
0	0	0	0	1	"System information broadcasting" message reception indication
0	0	1	1	1	"Optional information broadcasting" message reception indication
		Other			Reserved

5.5.3 MSG (PCH)

The format of message type for PCH is shown in Table 5.15, and the coding is shown in Table 5.16.

Table 5.15 Format of Message Type for PCH

Octet \ Bit	8	7	6	5	4	3	2	1
1	Message Type				Broadcasting Reception Indication			

Table 5.16 Message Type Coding for PCH

Bit	8	7	6	5	
	0	0	0	0	No paging
	0	0	0	1	"Paging type 1" message (single paging / 50 bits' Paging ID)
	0	0	1	0	"Paging type 2" message (single paging / 34 bits' Paging ID)
	0	0	1	1	"Paging type 3" message (single paging / 24 bits' Paging ID)
	0	1	0	0	"Paging type 4" message (multiplex paging / 34 bits' Paging ID)
	0	1	0	1	"Paging type 5" message (multiplex paging / 24 bits' Paging ID)
	0	1	1	0	"Paging type 6" message (paging and LCH assignment / 34 bits' Paging ID) LCH assignment does not include intermitted information of ICH.
	0	1	1	1	"Paging type 7" message (paging and LCH assignment / 24 bits' Paging ID) LCH assignment includes intermitted information of ICH.
		Other			Reserved

5.5.3.1 "No Paging" Message

Using this message, BS can notify MS of no paging in this PCH.

The message format is shown in Table 5.17, and the explanation of information elements is shown in Table 5.18.

Table 5.17 "No Paging" Message

Message type : "No Paging" message
 Direction : BS → MS (DL)
 Function channel : PCH

Octet \ Bit	8	7	6	5	4	3	2	1
1	0	0	0	0	Broadcasting Reception Indication			
2	Reserved							
3								
4								
5								
6								
7								
8								
9								
10								
11								
12								

Table 5.18 Information Elements in "No Paging" Message

Broadcasting Reception Indication (Octet 1)

It shows global definition information pattern or local information broadcasting reception indication of broadcasting information message other than "radio channel information broadcasting" message. Refer to Section 5.5.2.1 for global definition information pattern.

Bit	4	3	2	1	
-	-	-	-	0	<u>Global definition information pattern indication</u>
0	0	0	0	0	Global definition information pattern (0)
0	0	1	0	0	Global definition information pattern (1)
		:			:
1	1	1	0	0	Global definition information pattern (7)
-	-	-	-	1	<u>Local information broadcasting reception indication</u>
0	0	0	0	1	"System information broadcasting" message reception indication
0	0	1	1	1	"Optional information broadcasting" message reception indication
	Other				Reserved

Broadcasting Message Status Number m_i (Octet 12)

It shows the status number of the broadcasting message when Broadcasting Reception Indication indicates Local information broadcasting reception indication.

Broadcasting Reception Indication (Octet 1)		Meaning of m_i
Global definition information pattern indication		D.C.
Local information broadcasting reception indication	System information broadcasting message reception indication	m_{sys}
	Optional information broadcasting message reception indication	m_{opt}
Other		D.C.

Bit			
7	6	5	
0	0	0	$m_i = 0$
0	0	1	$m_i = 1$
0	1	0	$m_i = 2$
	:		:
1	1	1	$m_i = 7$

5.5.3.2 "Paging Type 1" Message (single paging / 50 bits' Paging ID)

Using this message, BS informs that MS received a paging. When MS responds to the paging from BS, it is necessary to request the link establishment. The message format is shown in Table 5.19, and the explanation of information elements is shown in Table 5.20.

Table 5.19 "Paging Type 1" Message

Message type : "Paging type 1" message
 Direction : BS → MS (DL)
 Function channel : PCH

Octet \ Bit	8	7	6	5	4	3	2	1
1	0	0	0	1	Broadcasting Reception Indication			
2	Paging ID							
3								
4								
5								
6								
7								
8								
9	Reserved							
10								
11								
12	Broadcasting Message Status Number mi							

Table 5.20 Information Elements in "Paging Type 1" Message

Broadcasting Reception Indication (Octet 1)

It shows global definition information pattern or local information broadcasting reception indication of broadcasting information message other than "radio channel information broadcasting" message. Refer to Section 5.5.2.1 for global definition information pattern.

Bit	4	3	2	1	
-	-	-	-	0	<u>Global definition information pattern indication</u>
0	0	0	0	0	Global definition information pattern (0)
0	0	1	0	0	Global definition information pattern (1)
		:			:
1	1	1	0	0	Global definition information pattern (7)
-	-	-	-	1	<u>Local information broadcasting reception indication</u>
0	0	0	0	1	"System information broadcasting" message reception indication
0	0	1	1	1	"Optional information broadcasting" message reception indication
	Other				Reserved

Paging ID (Octet 2 - 8)

Paging ID is specified as a 50 bits' number, and ID for identifying MS on the paging message. However, MSID can be allocated when Paging ID is a 34 bits' number.

Application Type (Octet 8)

It indicates application type.

Bit	6	5	4	3	2	1	
	0	0	0	0	0	0	Restoration from sleep state
	0	0	0	0	0	1	Voice
	0	0	0	0	1	0	Unrestricted digital information
	Other			Reserved			

Broadcasting Message Status Number m_i (Octet 12)

It shows the status number of the broadcasting message when Broadcasting Reception Indication indicates Local information broadcasting reception indication.

Broadcasting Reception Indication (Octet 1)		Meaning of m_i
Global definition information pattern indication		D.C.
Local information broadcasting reception indication	System information broadcasting message reception indication	m_{sys}
	Optional information broadcasting message reception indication	m_{opt}
Other		D.C.

Bit	7	6	5	
	0	0	0	$m_i = 0$
	0	0	1	$m_i = 1$
	0	1	0	$m_i = 2$
		:		:
	1	1	1	$m_i = 7$

5.5.3.3 "Paging Type 2" Message (single paging / 34 bits' Paging ID)

Using this message, BS informs that MS received a paging. When MS responds to the paging from BS, it is necessary to request the link establishment. The message format is shown in Table 5.21, and the explanation of information elements is shown in Table 5.22.

Table 5.21 "Paging Type 2" Message

Message type : "Paging type 2" message
 Direction : BS → MS (DL)
 Function channel : PCH

Octet \ Bit	8	7	6	5	4	3	2	1
1	0	0	1	0	Broadcasting Reception Indication			
2	Paging ID							
3								
4								
5								
6								
6	Application Type			Application Type				
7	Reserved							
8								
9								
10								
11								
12	Broadcasting Message Status Number mi							

Table 5.22 Information Elements in "Paging Type 2" Message

Broadcasting Reception Indication (Octet 1)

It shows global definition information pattern or local information broadcasting reception indication of broadcasting information message other than "radio channel information broadcasting" message. Refer to Section 5.5.2.1 for global definition information pattern.

Bit	4	3	2	1	
-	-	-	-	0	<u>Global definition information pattern indication</u>
0	0	0	0	0	Global definition information pattern (0)
0	0	1	0	0	Global definition information pattern (1)
		:			:
1	1	1	0	0	Global definition information pattern (7)

-	-	-	1	<u>Local information broadcasting reception indication</u>
0	0	0	1	"System information broadcasting message" reception indication
0	0	1	1	"Optional information broadcasting message" reception indication
Other				Reserved

Paging ID (Octet 2 - 6)

Paging ID is specified as a 34 bits' number, and ID for identifying MS on the paging message. Besides, MSID of a 34 bits' number can be allocated.

Application Type (Octet 6)

It indicates application type.

Bit						
6	5	4	3	2	1	
0	0	0	0	0	0	Restoration from sleep state
0	0	0	0	0	1	Voice
0	0	0	0	1	0	Unrestricted digital information
Other						Reserved

Broadcasting Message Status Number m_i (Octet 12)

It shows the status number of the broadcasting message when Broadcasting Reception Indication indicates Local information broadcasting reception indication.

Broadcasting Reception Indication (Octet 1)		Meaning of m_i
Global definition information pattern indication		D.C.
Local information broadcasting reception indication	System information broadcasting message reception indication	m_{sys}
	Optional information broadcasting message reception indication	m_{opt}
Other		D.C.

Bit			
7	6	5	
0	0	0	$m_i = 0$
0	0	1	$m_i = 1$
0	1	0	$m_i = 2$
	:		:
1	1	1	$m_i = 7$

5.5.3.4 "Paging Type 3" Message (single paging / 24 bits' Paging ID)

Using this message, BS informs that MS received a paging. When MS responds to the paging from BS, it is necessary to request the link establishment. The message format is shown in Table 5.23, and the explanation of information elements is shown in Table 5.24.

Table 5.23 "Paging Type 3" Message

Message type : "Paging type 3" message
 Direction : BS → MS (DL)
 Function channel : PCH

Octet \ Bit	8	7	6	5	4	3	2	1
1	0	0	1	1	Broadcasting Reception Indication			
	Message Type							
2	Paging ID							
3								
4								
5	Reserved			Application Type				
6	Reserved							
7								
8								
9								
10								
11								
12	Broadcasting Message Status Number mi							

Table 5.24 Information Elements in "Paging Type 3" Message

Broadcasting Reception Indication (Octet 1)

It shows global definition information pattern or local information broadcasting reception indication of broadcasting information message other than "radio channel information broadcasting" message. Refer to Section 5.5.2.1 for global definition information pattern.

Bit	4	3	2	1	
-	-	-	-	0	<u>Global definition information pattern indication</u>
0	0	0	0	0	Global definition information pattern (0)
0	0	1	0	0	Global definition information pattern (1)
		:			:
1	1	1	0	0	Global definition information pattern (7)
-	-	-	-	1	<u>Local information broadcasting reception indication</u>
0	0	0	0	1	"System information broadcasting" message reception

0 0 1 1 indication
 "Optional information broadcasting" message reception
 indication

Other Reserved

Paging ID (Octet 2 - 4)

Paging ID is specified as a 24 bits' number, and ID for identifying MS on the paging message. However, MSID can be allocated when Paging ID is a 34 bits' number.

Application Type (Octet 5)

It indicates application type.

Bit						
6	5	4	3	2	1	
0	0	0	0	0	0	Restoration from sleep state
0	0	0	0	0	1	Voice
0	0	0	0	1	0	Unrestricted digital information
						Other Reserved

Broadcasting Message Status Number m_i (Octet 12)

It shows the status number of the broadcasting message when Broadcasting Reception Indication indicates Local information broadcasting reception indication.

Broadcasting Reception Indication (Octet 1)		Meaning of m_i
Global definition information pattern indication		D.C.
Local information broadcasting reception indication	System information broadcasting message reception indication	m_{sys}
	Optional information broadcasting message reception indication	m_{opt}
Other		D.C.

Bit			
7	6	5	
0	0	0	$m_i = 0$
0	0	1	$m_i = 1$
0	1	0	$m_i = 2$
	:		:
1	1	1	$m_i = 7$

5.5.3.5 "Paging Type 4" Message (multiplex paging / 34 bits' Paging ID)

Using this message, BS informs that MS received a paging. When MS responds to the paging from BS, it is necessary to request the link establishment. The message format is shown in Table 5.25, and the explanation of information elements is shown in Table 5.26. Besides, this PCH may contain two messages.

Table 5.25 "Paging Type 4" Message

Message type : "Paging type 4" message
 Direction : BS → MS (DL)
 Function channel : PCH

Octet \ Bit	8	7	6	5	4	3	2	1
1	0	1	0	0	Broadcasting Reception Indication			
2	Paging ID							
3								
4								
5								
6								
7	Paging ID							
8								
9								
10								
11								
12	Re-served	Broadcasting Message Status Number mi						

Table 5.26 Information Elements in "Paging Type 4" Message

Broadcasting Reception Indication (Octet 1)

It shows global definition information pattern or local information broadcasting reception indication of broadcasting information message other than "radio channel information broadcasting" message. Refer to Section 5.5.2.1 for global definition information pattern.

Bit				
4	3	2	1	
-	-	-	0	<u>Global definition information pattern indication</u>
0	0	0	0	Global definition information pattern (0)
0	0	1	0	Global definition information pattern (1)
		:		:
1	1	1	0	Global definition information pattern (7)
-	-	-	1	<u>Local information broadcasting reception indication</u>
0	0	0	1	"System information broadcasting" message reception indication
0	0	1	1	"Optional information broadcasting" message reception indication
	Other			Reserved

Paging ID (Octet 2 - 6, 7 - 11)

Paging ID is specified as a 34 bits' number, and ID for identifying MS on the paging message. Besides, MSID of 34 bits' number can be allocated.

Application Type (Octet 6, 11)

It indicates application type.

Bit						
6	5	4	3	2	1	
0	0	0	0	0	0	Restoration from sleep state
0	0	0	0	0	1	Voice
0	0	0	0	1	0	Unrestricted digital information
	Other					Reserved

Broadcasting Message Status Number m_i (Octet 12)

It shows the status number of the broadcasting message when Broadcasting Reception Indication indicates Local information broadcasting reception indication.

Broadcasting Reception Indication (Octet 1)		Meaning of m_i
Global definition information pattern indication		D.C.
Local information broadcasting reception indication	System information broadcasting message reception indication	m_{sys}
	Optional information broadcasting message reception indication	m_{opt}
Other		D.C.

Bit			
7	6	5	
0	0	0	$m_i = 0$
0	0	1	$m_i = 1$
0	1	0	$m_i = 2$
	:		:
1	1	1	$m_i = 7$

5.5.3.6 "Paging Type 5" Message (multiplex paging / 24 bits' Paging ID)

Using this message, BS informs that MS received a paging. When MS responds to the paging from BS, it is necessary to request the link establishment. The message format is shown in Table 5.27, and the explanation of information elements is shown in Table 5.28.

Besides, this PCH may contain two messages.

Table 5.27 "Paging Type 5" Message

Message type : "Paging type 5" message
Direction : BS → MS (DL)
Function channel : PCH

Octet \ Bit	8	7	6	5	4	3	2	1
1	0	1	0	1	Broadcasting Reception Indication			
2	Paging ID							
3								
4								
5								
6	Paging ID							
7								
8								
9								
10	Reserved							
11								

12	Broadcasting Message Status Number m_i	
----	---	--

Table 5.28 Information Elements in "Paging Type 5" Message

Broadcasting Reception Indication (Octet 1)

It shows global definition information pattern or local information broadcasting reception indication of broadcasting information message other than "radio channel information broadcasting" message. Refer to Section 5.5.2.1 for global definition information pattern.

Bit	4	3	2	1	
-	-	-	-	0	<u>Global definition information pattern indication</u>
0	0	0	0	0	Global definition information pattern (0)
0	0	0	1	0	Global definition information pattern (1)
		:			:
1	1	1	1	0	Global definition information pattern (7)
-	-	-	-	1	<u>Local information broadcasting reception indication</u>
0	0	0	0	1	"System information broadcasting" message reception indication
0	0	0	1	1	"Optional information broadcasting" message reception indication
		Other			Reserved

Paging ID (Octet 2 - 4, 6 - 8)

Paging ID is specified as a 24 bits' number, and ID for identifying MS on the paging message. However, MSID can be allocated when Paging ID is a 34 bits' number.

Application Type (Octet 5, 9)

It indicates application type.

Bit	6	5	4	3	2	1	
0	0	0	0	0	0	0	Restoration from sleep state
0	0	0	0	0	0	1	Voice
0	0	0	0	0	1	0	Unrestricted digital information
		Other					Reserved

Broadcasting Message Status Number m_i (Octet 12)

It shows the status number of the broadcasting message when Broadcasting Reception Indication indicates Local information broadcasting reception indication.

Broadcasting Reception Indication (Octet 1)		Meaning of m_i
Global definition information pattern indication		D.C.
Local information broadcasting reception indication	System information broadcasting message reception indication	m_{sys}
	Optional information broadcasting message reception indication	m_{opt}
Other		D.C.

Bit			
7	6	5	
0	0	0	$m_i = 0$
0	0	1	$m_i = 1$
0	1	0	$m_i = 2$
	:		:
1	1	1	$m_i = 7$

5.5.3.7 "Paging Type 6" Message (paging and LCH assignment / 34 bits' Paging ID)

Using this message, BS informs that MS received a paging. When MS responds to the paging from BS, it is necessary to request the link establishment. The message format is shown in Table 5.29, and the explanation of information elements is shown in Table 5.30.

Besides, this PCH may contain a LCH assignment message.

Table 5.29 "Paging Type 6" Message

Message type : "Paging type 6" message
 Direction : BS → MS (DL)
 Function channel : PCH

Octet \ Bit	8	7	6	5	4	3	2	1
1	0	1	1	0	Broadcasting Reception Indication			
	Message Type							
2	Paging ID							
3								
4								
5								
6								
7	Sub-slot Number			Temporary LCH Number				
8	LCH Request Timing		Assignment PRU Number					
9	Shift Direction Control Information							
10	Reserved			Power Control Information				
11	TCCH Pattern Number				Reserved			
12	Re-served	Broadcasting Message Status Number mi						

(Note) Refer to Section 5.5.4.1.2 for information elements of LCH assignment message more than Octet 6.

Table 5.30 Information Elements in "Paging type 6" Message

Broadcasting Reception Indication (Octet 1)

It shows global definition information pattern or local information broadcasting reception indication of broadcasting information message other than "radio channel information broadcasting" message. Refer to Section 5.5.2.1 for global definition information pattern.

Bit	4	3	2	1	
-	-	-	-	0	<u>Global definition information pattern indication</u>
0	0	0	0	0	Global definition information pattern (0)
0	0	1	0	0	Global definition information pattern (1)
		:			:
1	1	1	0	0	Global definition information pattern (7)
-	-	-	-	1	<u>Local information broadcasting reception indication</u>
0	0	0	0	1	"System information broadcasting" message reception indication
0	0	1	1	1	"Optional information broadcasting" message reception indication
Other					Reserved

Paging ID(Octet 2 - 6)

Paging ID is specified as a 34 bits' number, and ID for identifying MS on the paging message. Besides, MSID of 34 bits' number can be allocated.

Application Type (Octet 6)

It indicates application type.

Bit	6	5	4	3	2	1	
0	0	0	0	0	0	0	Restoration from sleep state
0	0	0	0	0	0	1	Voice
0	0	0	0	0	1	0	Unrestricted digital information
Other							Reserved

Broadcasting Message Status Number m_i (Octet 12)

It shows the status number of the broadcasting message when Broadcasting Reception Indication indicates Local information broadcasting reception indication.

Broadcasting Reception Indication (Octet 1)		Meaning of m_i
Global definition information pattern indication		D.C.
Local information broadcasting reception indication	System information broadcasting message reception indication	m_{sys}
	Optional information broadcasting message reception indication	m_{opt}
Other		D.C.

Bit				
7	6	5		
0	0	0	$m_i = 0$	
0	0	1	$m_i = 1$	
0	1	0	$m_i = 2$	
	:		:	
1	1	1	$m_i = 7$	

5.5.3.8 "Paging Type 7" Message (paging and LCH assignment / 24 bits' Paging ID)

Using this message, BS informs that MS received a paging. When MS responds to the paging from BS, it is necessary to request the link establishment. The message format is shown in Table 5.31, and the explanation of information elements is shown in Table 5.32.

Besides, this PCH may contain a LCH assignment message.

Table 5.31 "Paging Type 7" Message

Message type : "Paging type 7" message
 Direction : BS → MS (DL)
 Function channel : PCH

Octet \ Bit	8	7	6	5	4	3	2	1
1	0	1	1	1	Broadcasting Reception Indication			
2	Paging ID							
3								
4								
5								
6	Sub-slot Number		Temporary LCH Number					
7	LCH Request Timing	Assignment PRU Number						
8	Shift Direction Control Information							
9	Reserved		Power Control Information					
10	TCCH Pattern Number				ICH Offset			
11	ICH Period				Reserved			
12	Re-served	Broadcasting Message Status Number m_i						

(Note) Refer to Section 5.5.4.1.3 for information elements of LCH assignment message more than Octet 5.

Table 5.32 Information Elements in "Paging Type 7" Message

Broadcasting Reception Indication (Octet 1)

It shows global definition information pattern or local information broadcasting reception indication of broadcasting information message other than "radio channel information broadcasting" message. Refer to Section 5.5.2.1 for global definition information pattern.

Bit				
4	3	2	1	
-	-	-	0	<u>Global definition information pattern indication</u>
0	0	0	0	Global definition information pattern (0)
0	0	1	0	Global definition information pattern (1)
		⋮		⋮
1	1	1	0	Global definition information pattern (7)
-	-	-	1	<u>Local information broadcasting reception indication</u>
0	0	0	1	"System information broadcasting" message reception indication
0	0	1	1	"Optional information broadcasting" message reception indication
Other				Reserved

Paging ID(Octet 2 - 4)

Paging ID is specified as a 24 bits' number, and ID for identifying MS on the paging message. However, MSID can be allocated when Paging ID is a 34 bits' number.

Application Type (Octet 5)

It indicates application type.

Bit						
6	5	4	3	2	1	
0	0	0	0	0	0	Restoration from sleep state
0	0	0	0	0	1	Voice
0	0	0	0	1	0	Unrestricted digital information
Other						Reserved

Broadcasting Message Status Number m_i (Octet 12)

It shows the status number of the broadcasting message when Broadcasting Reception Indication indicates Local information broadcasting reception indication.

Broadcasting Reception Indication (Octet 1)		Meaning of m_i
Global definition information pattern indication		D.C.
Local information broadcasting reception indication	System information broadcasting message reception indication	m_{sys}
	Optional information broadcasting message reception indication	m_{opt}
Other		D.C.

Bit			
7	6	5	
0	0	0	$m_i = 0$
0	0	1	$m_i = 1$
0	1	0	$m_i = 2$
	:		:
1	1	1	$m_i = 7$

5.5.4 MSG (SCCH)

5.5.4.1 DL SCCH

The format of message type for DL SCCH is shown in Table 5.33, and the coding is shown in Table 5.34.

Table 5.33 Format of Message Type for DL SCCH

Bit	8	7	6	5	4	3	2	1
Octet	Message type				Reserved			
1								

Table 5.34 Message Type Coding for DL SCCH

Bit	8	7	6	5	
0	0	0	0	0	"Idle" message
0	0	0	0	1	"LCH assignment 1" message
0	0	0	1	0	"LCH assignment 2" message
0	0	0	1	1	"LCH assignment 3" message
0	1	0	0	0	"LCH assignment standby" message
0	1	0	0	1	"LCH assignment reject" message
	Other			Reserved	

5.5.4.1.1 "Idle" Message

This message can be transmitted only when there is no information to be transmitted in DL SCCH. The message format is shown in Table 5.35.

Table 5.35 "Idle" Message

Message type : "Idle" message
 Direction : BS → MS (DL)
 Function channel : SCCH

Octet \ Bit	8	7	6	5	4	3	2	1
1	0	0	0	0	Reserved			
	Message Type							
2	Reserved							
3								
4								
5								
6								
7								
8								
9								
10								
11								
12								

5.5.4.1.2 "LCH Assignment 1" Message

BS uses this message to perform channel assignment in response to MS after a LCH assignment request from MS is received. The message format is shown in Table 5.36, and the explanation of information elements is shown in Table 5.37.

Besides, this SCCH may contain two messages. Octet 2-6 and Octet 7-11 of messages does not contain intermittent transmission timing information for ICH (Refer to Section 5.2.3.9). Each message is sent to different MS.

Table 5.36 "LCH Assignment 1" Message

Message type : "LCH assignment 1" message
 Direction : BS → MS (DL)
 Function channel : SCCH

Octet \ Bit	8	7	6	5	4	3	2	1
1	0	0	0	1	Reserved			
Message Type								
2	Sub-slot Number		Temporary LCH Number					
3	LCH Request Timing	Assignment PRU Number						
4	Shift Direction Control Information							
5	Reserved		Power Control Information					
6	TCCH Pattern Number				Reserved			
7	Sub-slot Number		Temporary LCH Number					
8	LCH Request Timing	Assignment PRU Number						
9	Shift Direction Control Information							
10	Reserved		Power Control Information					
11	TCCH Pattern Number				Reserved			
12	Reserved							

Table 5.37 Information Elements in "LCH Assignment 1" Message

Sub-slot Number (Octet 2, 7)

Sub-slot number indicates timing used by UL TCCH as shown in Sections 3.5.6 of OFDMA and 3.6.5 of SC.

Bit		
8	7	
<hr/>		
0	0	Sub-slot number 1
0	1	Sub-slot number 2
1	0	Sub-slot number 3
1	1	Sub-slot number 4

Temporary LCH Number (Octet 2, 7)

Temporary LCH number indicates temporary number to establish link channel.

Bit						
6	5	4	3	2	1	
<hr/>						
0	0	0	0	0	0	Temporary LCH number = 0
0	0	0	0	0	1	Temporary LCH number = 1
0	0	0	0	1	0	Temporary LCH number = 2
			:			:
1	1	1	1	1	1	Temporary LCH number = 63

LCH Request Timing (Octet 3, 8)

LCH request timing indicates LCCH timing of UL TCCH.

Bit		
8		
<hr/>		
0		UL TCCH timing before 2.5 ms
1		UL TCCH timing before LCCH interval value $n \times 5 + 2.5$ ms

Assignment PRU Number (Octet 3, 8)

Assignment PRU number indicates assigned number for PRU.

Bit							
7	6	5	4	3	2	1	
<hr/>							
0	0	0	0	0	0	0	Assignment PRU number = 1
0	0	0	0	0	0	1	Assignment PRU number = 2
0	0	0	0	0	1	0	Assignment PRU number = 3
			:				:
0	0	1	1	1	1	1	Assignment PRU number = 32
			Other				Reserved

Shift Direction Control Information (Octet 4, 9)

Shift direction control information indicates control information of UL transmission timing for MS.

Bit	8	7	6	5	4	3	2	1	
0	0	0	0	0	0	0	0	0	Stay
0	0	0	0	0	0	0	0	1	1 step forward
0	0	0	0	0	0	0	1	0	2 steps forward
0	0	0	0	0	0	0	1	1	3 steps forward
				:					:
1	1	1	1	1	1	1	1	1	255 steps forward

(Note) Unit = $-4 \times 30 / (512 + 64)$ us

Power Control Information (Octet 5, 10)

Power control information indicates control information of UL transmission power for MS.

Bit	6	5	4	3	2	1	
0	1	1	1	1	1	1	31 steps increase
0	1	1	1	1	1	0	30 steps increase
			:				:
0	0	0	0	0	1	0	2 steps increase
0	0	0	0	0	0	1	1 step increase
0	0	0	0	0	0	0	Hold
1	1	1	1	1	1	1	1 step decrease
1	1	1	1	1	1	0	2 steps decrease
			:				:
1	0	0	0	0	0	1	31 steps decrease
1	0	0	0	0	0	0	32 steps decrease

(Note) Unit = 3 dB

TCCH Pattern Number (Octet 6, 11)

TCCH pattern number indicates the core-sequence number of UL TCCH used as shown in Appendix D. "2nd LCH assignment message (Octet 7-11) absent " can be set only to TCCH pattern of Octet 11.

Bit	8	7	6	5	
	0	0	0	0	Core-sequence number 1 for OFDMA
	0	0	0	1	Core-sequence number 2 for OFDMA
	0	0	1	0	Core-sequence number 3 for OFDMA
	0	0	1	1	Core-sequence number 4 for OFDMA
	0	1	0	0	Core-sequence number 5 for OFDMA
	0	1	0	1	Core-sequence number 6 for OFDMA
	0	1	1	0	Core-sequence number 1 for SC
	0	1	1	1	Core-sequence number 2 for SC
	1	0	0	0	Core-sequence number 3 for SC
	1	0	0	1	Core-sequence number 4 for SC
	1	0	1	0	Core-sequence number 5 for SC
	1	0	1	1	Core-sequence number 6 for SC
		:			:
	1	1	1	0	Sub-slot number absent
	1	1	1	1	2nd LCH assignment message (Octet 7-11) absent
	Other			Reserved	

5.5.4.1.3 "LCH Assignment 2" Message

BS uses this message to perform channel assignment in response to MS after a LCH assignment request from MS is received. The message format is shown in Table 5.38, and the explanation of information elements is shown in Table 5.39.

Besides, this SCCH may contain two messages. The message from Octet 2-7 contains intermittent transmission timing information for ICH (Refer to Section 5.2.3.9). And the message from Octet 8-12 does not contain it. Each message is sent to different MS.

Table 5.38 "LCH Assignment 2" Message

Message type : "LCH assignment 2" message
 Direction : BS → MS (DL)
 Function channel : SCCH

Octet \ Bit	8	7	6	5	4	3	2	1
1	0	0	1	0	Reserved			
Message Type								
2	Sub-slot Number		Temporary LCH Number					
3	LCH Request Timing	Assignment PRU Number						
4	Shift Direction Control Information							
5	Reserved		Power Control Information					
6	TCCH Pattern Number				ICH Offset			
7	ICH Period				Reserved			
8	Sub-slot Number		Temporary LCH Number					
9	LCH Request Timing	Assignment PRU Number						
10	Shift Direction Control Information							
11	Reserved		Power Control Information					
12	TCCH Pattern Number							

Table 5.39 Information Elements in "LCH Assignment 2" Message

Sub-slot Number (Octet 2, 8)

Sub-slot number indicates timing used by UL TCCH as shown in Sections 3.5.6 of OFDMA and 3.6.5 of SC.

Bit	8	7	
	0	0	Sub-slot number 1
	0	1	Sub-slot number 2
	1	0	Sub-slot number 3
	1	1	Sub-slot number 4

Temporary LCH Number (Octet 2, 8)

Temporary LCH number indicates temporary number to establish link channel.

Bit	6	5	4	3	2	1	
0	0	0	0	0	0	0	Temporary LCH number = 0
0	0	0	0	0	0	1	Temporary LCH number = 1
0	0	0	0	0	1	0	Temporary LCH number = 2
			:				:
1	1	1	1	1	1	1	Temporary LCH number = 63

LCH Request Timing (Octet 3, 9)

LCH request timing indicates LCCH timing of UL TCCH.

Bit	8	
0		UL TCCH timing before 2.5 ms
1		UL TCCH timing before LCCH interval value $n \times 5 + 2.5$ ms

Assignment PRU Number (Octet 3, 9)

Assignment PRU number indicates assigned number for PRU.

Bit	7	6	5	4	3	2	1	
0	0	0	0	0	0	0	0	Assignment PRU number = 1
0	0	0	0	0	0	0	1	Assignment PRU number = 2
0	0	0	0	0	0	1	0	Assignment PRU number = 3
			:					:
0	0	1	1	1	1	1	1	Assignment PRU number = 32
			Other					Reserved

Shift Direction Control Information (Octet 4, 10)

Shift direction control information indicates control information of UL transmission timing for MS.

Bit	8	7	6	5	4	3	2	1	
0	0	0	0	0	0	0	0	0	Stay
0	0	0	0	0	0	0	0	1	1 step forward
0	0	0	0	0	0	0	1	0	2 steps forward
0	0	0	0	0	0	0	1	1	3 steps forward
				:					:
1	1	1	1	1	1	1	1	1	255 steps forward

(Note) Unit = $-4 \times 30 / (512 + 64)$ us

Power Control Information (Octet 5, 11)

Power control information indicates control information of UL transmission power for MS.

Bit	6	5	4	3	2	1	
0	1	1	1	1	1	1	31 steps increase
0	1	1	1	1	1	0	30 steps increase
			:				:
0	0	0	0	0	1	0	2 steps increase
0	0	0	0	0	0	1	1 step increase
0	0	0	0	0	0	0	Hold
1	1	1	1	1	1	1	1 step decrease
1	1	1	1	1	1	0	2 steps decrease
			:				:
1	0	0	0	0	0	1	31 steps decrease
1	0	0	0	0	0	0	32 steps decrease

(Note) Unit = 3 dB

Bit	8	7	6	5	
0	0	0	0	0	No scheduling
0	0	0	0	1	10 ms
0	0	1	0		15 ms
0	0	1	1		20 ms
		:			:
1	1	1	1		80 ms

5.5.4.1.4 "LCH Assignment 3" Message

BS uses this message to perform channel assignment in response to MS after a LCH assignment request from MS is received. The message format is shown in Table 5.40, and the explanation of information elements is shown in Table 5.41.

Besides, this SCCH include MSID.

Table 5.40 "LCH Assignment 3" Message

Message type : "LCH assignment 3" message

Direction : BS → MS (DL)

Function channel : SCCH

Octet \ Bit	8	7	6	5	4	3	2	1	
1	0	0	1	1	Reserved				
		Message Type							
2	Sub-slot Number		Temporary LCH Number						
3	LCH Request Timing	Assignment PRU Number							
4	Shift Direction Control Information								
5	Reserved		Power Control Information						
6	TCCH Pattern Number				ICH Offset				
7	ICH Period				Reserved				
8	MSID								
9									
10									
11									
12									Reserved

Table 5.41 Information Elements in "LCH Assignment 3" Message

Sub-slot Number (Octet 2)

Sub-slot number indicates timing used by UL TCCH as shown in Sections 3.5.6 of OFDMA and 3.6.5 of SC.

Bit		
8	7	
0	0	Sub-slot number 1
0	1	Sub-slot number 2
1	0	Sub-slot number 3
1	1	Sub-slot number 4

Temporary LCH Number (Octet 2)

Temporary LCH number indicates temporary number to establish link channel.

Bit						
6	5	4	3	2	1	
0	0	0	0	0	0	Temporary LCH number = 0
0	0	0	0	0	1	Temporary LCH number = 1
0	0	0	0	1	0	Temporary LCH number = 2
			:			:
1	1	1	1	1	1	Temporary LCH number = 63

LCH Request Timing (Octet 3)

LCH request timing indicates LCCH timing of UL TCCH.

Bit	
8	
0	UL TCCH timing before 2.5 ms
1	UL TCCH timing before LCCH interval value $n \times 5 + 2.5$ ms

Assignment PRU Number (Octet 3)

Assignment PRU number indicates assigned number for PRU.

Bit							
7	6	5	4	3	2	1	
0	0	0	0	0	0	0	Assignment PRU number = 1
0	0	0	0	0	0	1	Assignment PRU number = 2
0	0	0	0	0	1	0	Assignment PRU number = 3
			:				:
0	0	1	1	1	1	1	Assignment PRU number = 32
			Other				Reserved

Shift Direction Control Information (Octet 4)

Shift direction control information indicates control information of UL transmission timing for MS.

Bit	8	7	6	5	4	3	2	1	
0	0	0	0	0	0	0	0	0	Stay
0	0	0	0	0	0	0	0	1	1 step forward
0	0	0	0	0	0	0	1	0	2 steps forward
0	0	0	0	0	0	0	1	1	3 steps forward
				:					:
1	1	1	1	1	1	1	1	1	255 steps forward

(Note) Unit = $-4 \times 30 / (512 + 64)$ us

Power Control Information (Octet 5)

Power control information indicates control information of UL transmission power for MS.

Bit	6	5	4	3	2	1	
0	1	1	1	1	1	1	31 steps increase
0	1	1	1	1	1	0	30 steps increase
			:				
0	0	0	0	0	1	0	2 steps increase
0	0	0	0	0	0	1	1 step increase
0	0	0	0	0	0	0	Hold
1	1	1	1	1	1	1	1 step decrease
1	1	1	1	1	1	0	2 steps decrease
			:				:
1	0	0	0	0	0	1	31 steps decrease
1	0	0	0	0	0	0	32 steps decrease

(Note) Unit = 3 dB

TCCH Pattern Number (Octet 6)

TCCH pattern number indicates the core-sequence number that the UL TCCH used as shown in Appendix D. MSID is absent when TCCH pattern number is not "Sub-slot number absent / MSID present".

Bit	8	7	6	5	
0	0	0	0	0	Core-sequence number 1 for OFDMA
0	0	0	1	0	Core-sequence number 2 for OFDMA
0	0	1	0	0	Core-sequence number 3 for OFDMA
0	0	1	1	0	Core-sequence number 4 for OFDMA
0	1	0	0	0	Core-sequence number 5 for OFDMA
0	1	0	1	0	Core-sequence number 6 for OFDMA
0	1	1	0	0	Core-sequence number 1 for SC
0	1	1	1	0	Core-sequence number 2 for SC
1	0	0	0	0	Core-sequence number 3 for SC
1	0	0	1	0	Core-sequence number 4 for SC
1	0	1	0	0	Core-sequence number 5 for SC
1	0	1	1	0	Core-sequence number 6 for SC
		:			:
1	1	1	0	0	Sub-slot number absent / MSID present
					Other
					Reserved

ICH Offset (Octet 6)

The frame used as ICH is indicated by the offset of the TDMA frame from CCH.

Refer to Section 5.2.3.9 for intermittent transmission timing of ICH offset.

When intermittent transmission timing information of ICH is not needed, "no offset" is set.

Bit	4	3	2	1	
0	0	0	0	0	No offset
0	0	0	0	1	TDMA frame after 5 ms from CCH
0	0	0	1	0	TDMA frame after 10 ms from CCH
0	0	0	1	1	TDMA frame after 15 ms from CCH
		:			:
1	1	1	1	1	TDMA frame after 75 ms from CCH

ICH Period (Octet 7)

The cycle of the TDMA frame that ICH uses is indicated.

Refer to Section 5.2.3.9 for intermittent transmission timing of ICH period.

When intermittent transmission timing information of ICH is not needed, "no scheduling" is set.

$ICH\ Offset \leq ICH\ Period - 5ms$

Bit	8	7	6	5	
0	0	0	0	0	No scheduling
0	0	0	0	1	10 ms
0	0	1	0		15 ms
0	0	1	1		20 ms
		:			:
1	1	1	1		80 ms

MSID (Octet 8 - 12)

The length of MSID is 34 bits.

5.5.4.1.5 "LCH Assignment Standby" Message

BS uses this message to inform BS to standby. The message format is shown in Table 5.42, and the explanation of information elements is shown in Table 5.43.

Table 5.42 "LCH Assignment Standby" Message

Message type : "LCH assignment standby" message
 Direction : BS → MS (DL)
 Function channel : SCCH

Octet \ Bit	8	7	6	5	4	3	2	1
1	0 1 0 0 Message Type				Reserved			
2	Sub-slot Number			Temporary LCH Number				
3	LCH Request Timing	Reserved			Cause			
4	Reserved							
5								
6	TCCH Pattern Number				Reserved			
7	Sub-slot Number			Temporary LCH Number				
8	LCH Request Timing	Assignment PRU Number						
9	Shift Direction Control Information							
10	Reserved			Power Control Information				
11	TCCH Pattern Number				ICH Offset			
12	ICH Period							

Table 5.43 Information Elements in "LCH Assignment Standby" Message

Sub-slot Number (Octet 2, 7)

Sub-slot number indicates timing used by UL TCCH as shown in Sections 3.5.6 of OFDMA and 3.6.5 of SC.

Bit		
8	7	
0	0	Sub-slot number 1
0	1	Sub-slot number 2
1	0	Sub-slot number 3
1	1	Sub-slot number 4

Temporary LCH Number (Octet 2, 7)

Temporary LCH number indicates temporary number to establish link channel.

Bit						
6	5	4	3	2	1	
0	0	0	0	0	0	Temporary LCH number = 0
0	0	0	0	0	1	Temporary LCH number = 1
0	0	0	0	1	0	Temporary LCH number = 2
			:			:
1	1	1	1	1	1	Temporary LCH number = 63

LCH Request Timing (Octet 3, 8)

LCH request timing indicates LCCH timing of UL TCCH.

Bit		
8		
0		UL TCCH timing before 2.5 ms
1		UL TCCH timing before LCCH interval value $n \times 5 + 2.5$ ms

Cause (Octet 3)

Cause indicates standby reason.

Bit					
5	4	3	2	1	
0	0	0	0	0	Reserved
0	0	0	0	1	All BS slots in use
0	0	0	1	0	No BS free channel
0	0	0	1	1	No free outgoing line on wire side
0	0	1	0	0	LCH type disagreement
0	0	1	0	1	Traffic restriction
0	0	1	1	0	Relevant BS use impossible (zone selection impossible)
		Other			Reserved

TCCH Pattern Number (Octet 6, 11)

TCCH pattern number indicates the core-sequence number of UL TCCH used as shown in Appendix D. "LCH assignment message (Octet 7 - 12) absent " can be set only to TCCH pattern of Octet 11.

Bit	8	7	6	5	
	0	0	0	0	Core-sequence number 1 for OFDMA
	0	0	0	1	Core-sequence number 2 for OFDMA
	0	0	1	0	Core-sequence number 3 for OFDMA
	0	0	1	1	Core-sequence number 4 for OFDMA
	0	1	0	0	Core-sequence number 5 for OFDMA
	0	1	0	1	Core-sequence number 6 for OFDMA
	0	1	1	0	Core-sequence number 1 for SC
	0	1	1	1	Core-sequence number 2 for SC
	1	0	0	0	Core-sequence number 3 for SC
	1	0	0	1	Core-sequence number 4 for SC
	1	0	1	0	Core-sequence number 5 for SC
	1	0	1	1	Core-sequence number 6 for SC
			:		:
	1	1	1	0	Sub-slot number absent
	1	1	1	1	LCH assignment message (Octet 7-12) absent

Assignment PRU Number (Octet 8)

Assignment PRU number indicates assigned number for PRU.

Bit	7	6	5	4	3	2	1	
	0	0	0	0	0	0	0	Assignment PRU number = 1
	0	0	0	0	0	0	1	Assignment PRU number = 2
	0	0	0	0	0	1	0	Assignment PRU number = 3
				:				:
	0	0	1	1	1	1	1	Assignment PRU number = 32
				Others				Reserved

Shift Direction Control Information (Octet 9)

Shift direction control information indicates control information of UL transmission timing for MS.

Bit	8	7	6	5	4	3	2	1	
	0	0	0	0	0	0	0	0	Stay
	0	0	0	0	0	0	0	1	1 step forward
	0	0	0	0	0	0	1	0	2 steps forward
	0	0	0	0	0	0	1	1	3 steps forward
				:					:

1 1 1 1 1 1 1 1 255 steps forward

(Note) Unit = $-4 \times 30 / (512 + 64)$ us

Power Control Information (Octet 10)

Power control information indicates control information of UL transmission power for MS.

Bit	6	5	4	3	2	1	
0	1	1	1	1	1	1	31 steps increase
0	1	1	1	1	1	0	30 steps increase
			:				
0	0	0	0	1	0		2 steps increase
0	0	0	0	0	1		1 step increase
0	0	0	0	0	0		Hold
1	1	1	1	1	1		1 step decrease
1	1	1	1	1	0		2 steps decrease
			:				
1	0	0	0	0	1		31 steps decrease
1	0	0	0	0	0		32 steps decrease

(Note) Unit = 3 dB

ICH Offset (Octet 11)

The frame used with ICH is indicated by the offset of CCH from the TDMA frame.

Refer to Section 5.2.3.9 for intermittent transmission timing of ICH offset.

When intermittent transmission timing information of ICH is not needed, "no offset" is set.

Bit	4	3	2	1	
0	0	0	0	0	No offset
0	0	0	0	1	TDMA frame after 5 ms from CCH
0	0	1	0		TDMA frame after 10 ms from CCH
0	0	1	1		TDMA frame after 15 ms from CCH
		:			:
1	1	1	1		TDMA frame after 75 ms from CCH

ICH Period (Octet 12)

The cycle of the TDMA frame that ICH uses is indicated.

Refer to Section 5.2.3.9 for intermittent transmission timing of ICH period.

When intermittent transmission timing information of ICH is not needed, "no scheduling" is set.

ICH Offset \leq ICH Period – 5ms

Bit	8	7	6	5	
0	0	0	0	0	No scheduling

0	0	0	1	10 ms
0	0	1	0	15 ms
0	0	1	1	20 ms
		:		:
1	1	1	1	80 ms

5.5.4.1.6 "LCH Assignment Reject" Message

BS uses this message to inform that channel setup is not possible in response to a link channel (re-)request from MS. The message format is shown in Table 5.44, and the explanation of information elements is shown in Table 5.45.

Table 5.44 "LCH Assignment Reject" Message

Message type : "LCH assignment reject" message
Direction : BS → MS (DL)
Function channel : SCCH

Octet \ Bit	8	7	6	5	4	3	2	1
1	0	1	0	1	Reserved			
Message Type								
2	Sub-slot Number			Temporary LCH Number				
3	LCH Request Timing	Reserved		Cause				
4	Reserved							
5								
6	TCCH Pattern Number				Reserved			
7	Sub-slot Number			Temporary LCH Number				
8	LCH Request Timing	Assignment PRU Number						
9	Shift Direction Control Information							
10	Reserved			Power Control Information				
11	TCCH Pattern Number				ICH Offset			
12	ICH Period							

Table 5.45 Information Elements in "LCH Assignment Reject" Message

Sub-slot Number (Octet 2, 7)

Sub-slot number indicates timing used by UL TCCH as shown in Sections 3.5.6 of OFDMA and 3.6.5 of SC.

Bit		
8	7	
0	0	Sub-slot number 1
0	1	Sub-slot number 2
1	0	Sub-slot number 3
1	1	Sub-slot number 4

Temporary LCH Number (Octet 2, 7)

Temporary LCH number indicates temporary number to establish link channel.

Bit						
6	5	4	3	2	1	
0	0	0	0	0	0	Temporary LCH number = 0
0	0	0	0	0	1	Temporary LCH number = 1
0	0	0	0	1	0	Temporary LCH number = 2
			:			:
1	1	1	1	1	1	Temporary LCH number = 63

LCH Request Timing (Octet 3, 8)

LCH request timing indicates LCCH timing of UL TCCH.

Bit		
8		
0		UL TCCH timing before 2.5 ms
1		UL TCCH timing before LCCH interval value $n \times 5 + 2.5$ ms

Cause (Octet 3)

Cause indicates rejected reason.

Bit					
5	4	3	2	1	
0	0	0	0	0	Reserved
0	0	0	0	1	All BS slots in use
0	0	0	1	0	No BS free channel
0	0	0	1	1	No free outgoing line on wire side
0	0	1	0	0	LCH type disagreement
0	0	1	0	1	Traffic restriction
0	0	1	1	0	Relevant BS use impossible (zone selection impossible)

Other

Reserved

TCCH Pattern Number (Octet 6, 11)

TCCH pattern number indicates the core-sequence number of UL TCCH used as shown in Appendix D. "LCH assignment message (Octet 7 - 12) absent " can be set only to TCCH pattern of Octet 12.

Bit	8	7	6	5	
	0	0	0	0	Core-sequence number 1 for OFDMA
	0	0	0	1	Core-sequence number 2 for OFDMA
	0	0	1	0	Core-sequence number 3 for OFDMA
	0	0	1	1	Core-sequence number 4 for OFDMA
	0	1	0	0	Core-sequence number 5 for OFDMA
	0	1	0	1	Core-sequence number 6 for OFDMA
	0	1	1	0	Core-sequence number 1 for SC
	0	1	1	1	Core-sequence number 2 for SC
	1	0	0	0	Core-sequence number 3 for SC
	1	0	0	1	Core-sequence number 4 for SC
	1	0	1	0	Core-sequence number 5 for SC
	1	0	1	1	Core-sequence number 6 for SC
			:		:
	1	1	1	0	Sub-slot number absent
	1	1	1	1	LCH assignment message (Octet 7-12) absent

Assignment PRU Number (Octet 8)

Assignment PRU number indicates assigned number for PRU.

Bit	7	6	5	4	3	2	1	
	0	0	0	0	0	0	0	Assignment PRU number = 1
	0	0	0	0	0	0	1	Assignment PRU number = 2
	0	0	0	0	0	1	0	Assignment PRU number = 3
				:				:
	1	0	0	1	1	1	1	Assignment PRU number = 80
				Others				Reserved

Shift Direction Control Information (Octet 9)

Shift direction control information indicates control information of UL transmission timing for MS.

Bit	8	7	6	5	4	3	2	1	
	0	0	0	0	0	0	0	0	Stay

0	0	0	0	0	0	0	1	1 step forward
0	0	0	0	0	0	1	0	2 steps forward
0	0	0	0	0	0	1	1	3 steps forward
				:				:
1	1	1	1	1	1	1	1	255 steps forward

(Note) Unit = $-4 \times 30 / (512 + 64)$ us

Power Control Information (Octet 10)

Power control information indicates control information of UL transmission power for MS.

Bit								
6	5	4	3	2	1			
0	1	1	1	1	1			31 steps increase
0	1	1	1	1	0			30 steps increase
			:					
0	0	0	0	1	0			2 steps increase
0	0	0	0	0	1			1 step increase
0	0	0	0	0	0			Hold
1	1	1	1	1	1			1 step decrease
1	1	1	1	1	0			2 steps decrease
			:					:
1	0	0	0	0	1			31 steps decrease
1	0	0	0	0	0			32 steps decrease

(Note) Unit = 3 dB

ICH Offset (Octet 11)

The frame used with ICH is indicated by the offset of CCH from the TDMA frame.

Refer to Section 5.2.3.9 for intermittent transmission timing of ICH offset.

When intermittent transmission timing information of ICH is not needed, "no offset" is set.

Bit					
4	3	2	1		
0	0	0	0		No offset
0	0	0	1		TDMA frame after 5 ms from CCH
0	0	1	0		TDMA frame after 10 ms from CCH
0	0	1	1		TDMA frame after 15 ms from CCH
		:			:
1	1	1	1		TDMA frame after 75 ms from CCH

ICH Period (Octet 12)

The cycle of the TDMA frame that ICH uses is indicated.

Refer to Section 5.2.3.9 for intermittent transmission timing of ICH period.

When intermittent transmission timing information of ICH is not needed, "no scheduling" is set.

ICH Offset \leq ICH Period – 5ms

Bit	8	7	6	5	
0	0	0	0	0	No scheduling
0	0	0	0	1	10 ms
0	0	1	0		15 ms
0	0	1	1		20 ms
		:			:
1	1	1	1		80 ms

5.5.4.2 UL SCCH

The format of message type for UL SCCH is shown in Table 5.46, and the coding is shown in Table 5.47.

Table 5.46 Format of Message Type for UL SCCH

Octet \ Bit	8	7	6	5	4	3	2	1
1	Message Type				Reserved			

Table 5.47 Message Type Coding for UL SCCH

Bit	8	7	6	5	
0	0	1	0		"LCH assignment re-request" message
	Other				Reserved

5.5.4.2.1 "LCH Assignment Re-request" Message

MS can use this message for LCH re-assignment after a LCH assignment message from BS is received. The message format is shown in Table 5.48, and the explanation of information elements is shown in Table 5.49.

Table 5.48 "LCH Assignment Re-request" Message

Message type : "LCH Assignment re-request" message
 Direction : BS ← MS (UL)
 Function channel : SCCH

Octet \ Bit	8	7	6	5	4	3	2	1
1	0	0	1	0	Reserved			
	Message Type							
2	Reserved		Temporary LCH Number					
3	Reserved			Cause				
4	TDMA Slot							

Table 5.49 Information Elements in "LCH Assignment Re-request" Message

Temporary LCH Number (Octet 2)

Temporary LCH number indicates temporary number to establish link channel.

Bit	6	5	4	3	2	1	
	0	0	0	0	0	0	Temporary LCH number = 0
	0	0	0	0	0	1	Temporary LCH number = 1
	0	0	0	0	1	0	Temporary LCH number = 2
			:				:
	1	1	1	1	1	1	Temporary LCH number = 63

Cause (Octet 3)

Cause indicates re-request reason.

Bit	5	4	3	2	1	
0	0	0	0	0	0	Reserved
0	0	0	0	0	1	Assignment PRU use not possible
0	0	0	0	1	0	Assignment PRU non-corresponding MS
0	0	0	0	1	1	Assignment Scheduling term not possible
0	0	0	1	0	0	Request for assignment PRU
			Other			Reserved

TDMA Slot (Octet 4)

This information element indicates the TDMA slot that MS can use.

Bit	8	7	6	5	
-	-	-	-	1/0	1st TDMA slot can be / not used.
-	-	-	1/0	-	2nd TDMA slot can be / not used.
-	1/0	-	-	-	3rd TDMA slot can be / not used.
1/0	-	-	-	-	4th TDMA slot can be / not used.

Chapter 6 Channel Assignment

6.1 Overview

This chapter describes the link establishment control, the channel assignment control and the connection control specification for radio-link. In Section 6.2, link establishment control is described. Channel assignment control is described in Section 6.3; and connection control is described in Section 6.4. Section 6.4 also defines the two channel access modes called “Fast access channel based on MAP mode (FM-Mode)” and “high Quality channel based on carrier sensing mode (QS-Mode)”. FM-Mode is used for high-speed packet access. PRUs of EXCH are shared among MSs in FM-Mode. QS-Mode is used mainly for applications which require guaranteed bandwidth or low latency. One PRU is dedicatedly assigned to one MS while the data traffic is continued in QS-Mode. Radio state management is defined in Section 6.5; and parameters introduced in this chapter are summarized in Section 6.6.

6.2 Link Establishment Control

The sequences of incoming call and outgoing call are shown in Figure 6.1 and Figure 6.2.

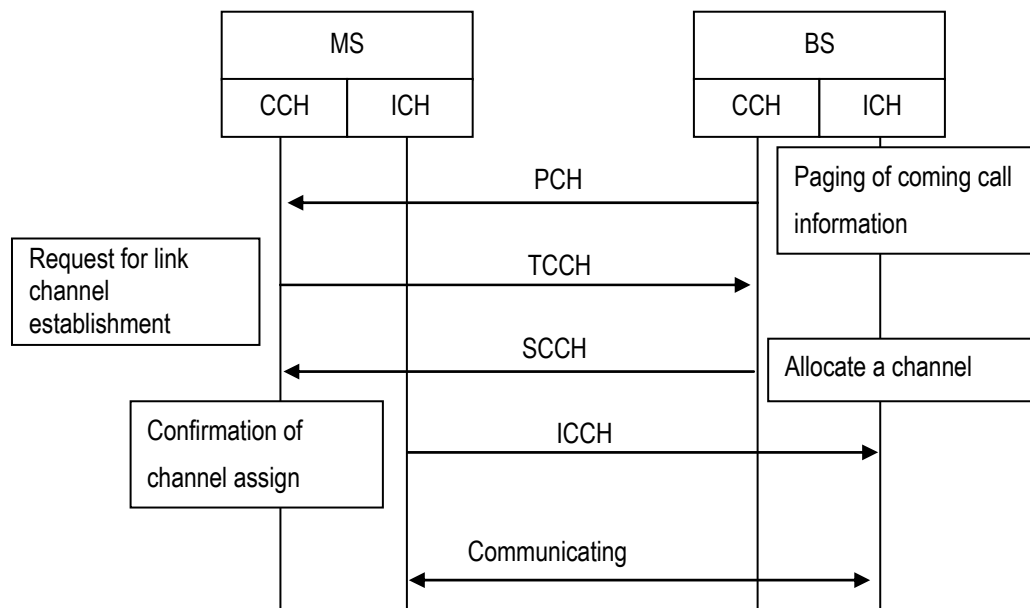

Figure 6.1 Incoming Call Sequence

The sequence of an incoming call is initiated by BS's transmitting PCH to MS. PCH includes information on the MS being paged. By receiving the PCH from BS, MS is informed of the incoming call, and is requested to respond to the PCH. The MS indicated by the PCH transmits TCCH as "LCH assignment request" message in UL CCH. MS shall choose one pattern using random logic from 24 patterns consisting of Sub-slot (4 patterns) and Core-sequence number (6

patterns). Upon the reception of TCCH by the BS, the BS transmits DL SCCH to notify the allocation of a communication channel to the MS. DL SCCH transports information not only on the allocated channel but also on the transmission power and transmission timing that the MS should use. Note that the BS can only recognize the MS by TCCH rather than MSID. After receiving the channel allocation in response to the transmitted TCCH in the assigned communication channel, the MS transmits the allocation confirmation to the BS with the rectified transmission power and transmission timing.

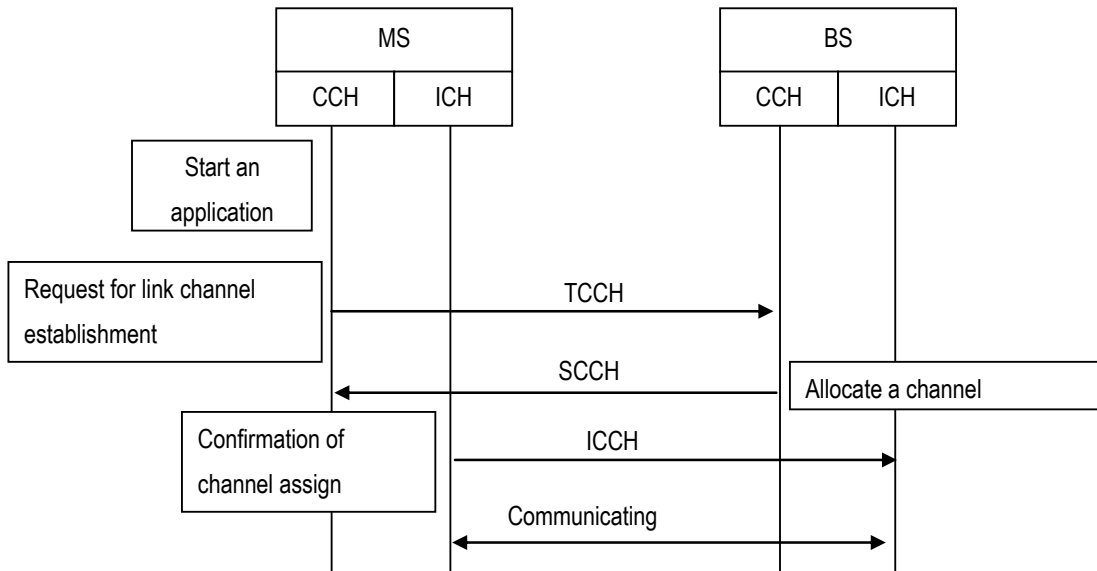

Figure 6.2 Outgoing Call Sequence

Outgoing call sequence is initiated by MS's transmitting TCCH in UL CCH. MS chooses one of four sub-slots within a slot to transmit the TCCH in the UL CCH. The details on the sub-slots are defined in Chapter 3. Not like the incoming call sequence, outgoing sequence can be initiated in an arbitrary UL CCH. Outgoing call sequence after the transmission of TCCH is the same as the incoming call sequence.

Even when the BS receives two or more TCCHs from two or more MSs simultaneously, the BS can allocate a communication channel to each MS, as long as the BS can recognize and identify each TCCH.

Figure 6.3 shows relation between LCH Assignment Request (TCCH) and LCH Assignment (SCCH). MS sends 2.5 ms or $n * 5 + 2.5$ ms before from downlink SCCH. Therefore, when a MS sends LCH Assignment Request at timing (1), then the BS responses its LCH Assignment (SCCH) at timing (2) or (3).

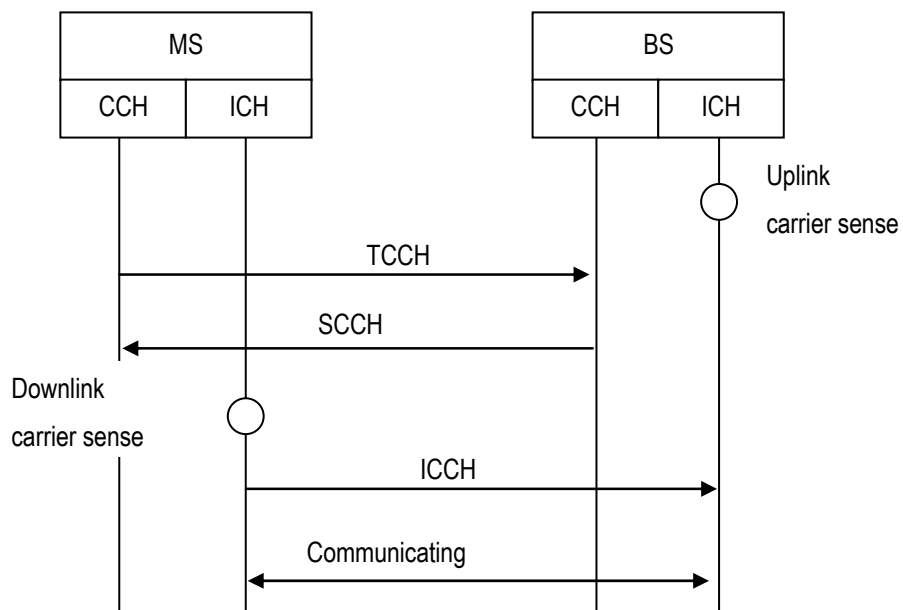

Figure 6.4 Channel Assign Control

6.4 Connection Control

6.4.1 FM-Mode

6.4.1.1 Connection Control

Figure 6.5 shows the overview of the FM-Mode. The figure shows two MSs [MS1 and MS2] accessing ICHs based on FM-Mode controlled by the BS. BS indicates the PRUs to MSs in active state through the MAP field in DL ECCH. When MS receives the MAP field, it receives the information of which PRUs can be used for communication. Then MS uses these PRUs for communication with the BS.

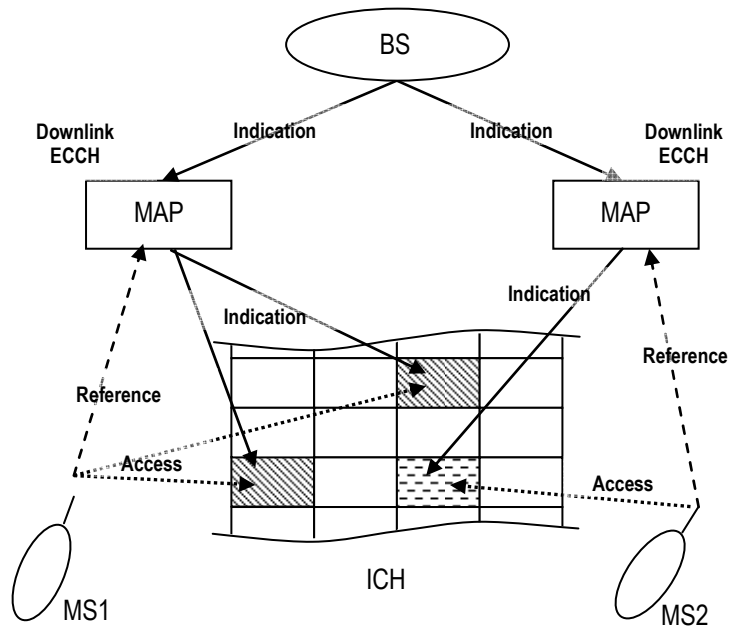

Figure 6.5 Connection Control of FM-Mode

For more information on the relationship between the MAP field and PRUs for FM-Mode, refer to Section 4.3.6.7.

BS assigns EXCHs to MS by sending MAP field on ECCH. Figure 6.6 shows an example of EXCHs assignment to two MSs. In this figure, MAP in the ANCH refers to the EXCH assigned to the MS with MAP. MS1 and MS2 are sharing the same PRUs for EXCH in this figure.

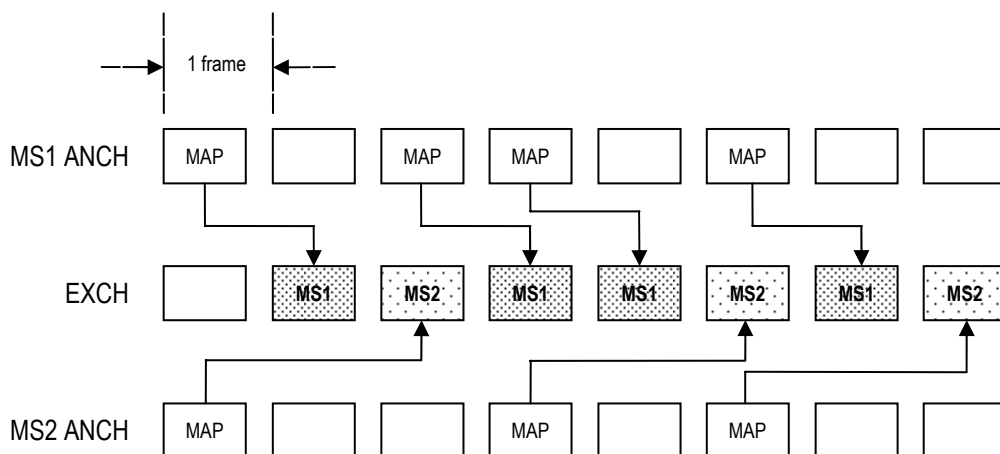

Figure 6.6 An Example of EXCH Assignment to Two MSs

6.4.1.1.1 Access Timing

According to the slot number of allocated ANCH and the MS's processing capability, access timing to use EXCH after the reception of MAP field is defined. Two access timings are defined in the following.

Figure 6.7 describes an example of relative timing of EXCH to ANCH in case of access timing 1, in which the allocated EXCH is used by the MS in the next TDMA frame after the MAP is received on the DL ANCH.

Figure 6.8 describes an example of relative timing of EXCH to ANCH in case of access timing 2, in which the allocated EXCH is used by the MS in the second next or later TDMA frame after the MAP is received on the DL ANCH. In the figures, ANCH can be allocated in any of the 4 DL TDMA slots. The access frame in the figures indicates the TDMA frame where the communication access on the allocated EXCH is possible.

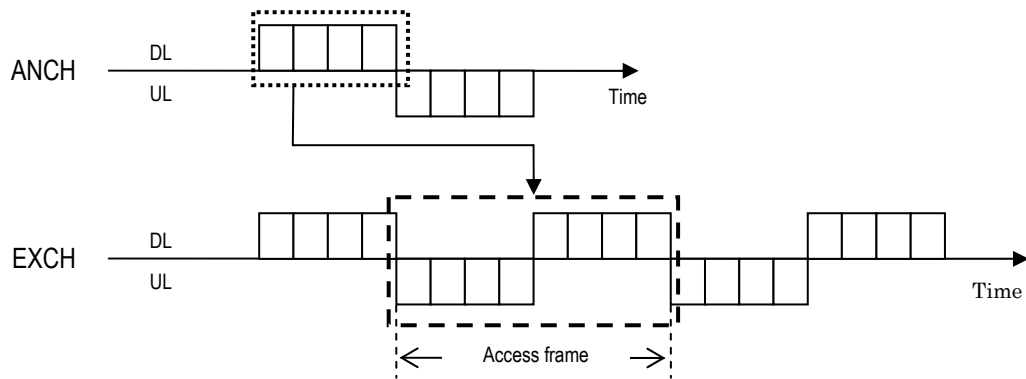

Figure 6.7 Access Timing 1

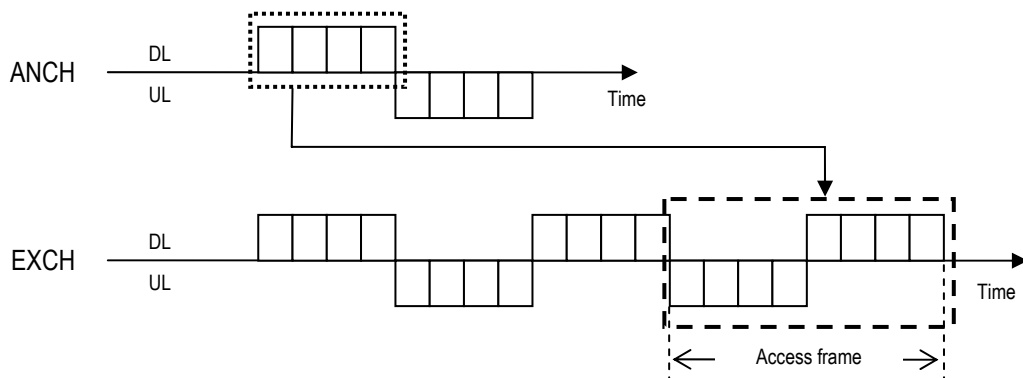

Figure 6.8 Access Timing 2

Table 6.1 shows processing capabilities of different MSs.

Table 6.1 MS Processing Capabilities

	MS processing capabilities	Explanation
High ↑	Level 0	Processing completes during the guard time between TDD UL and DL. (51.67 us). MS can access the frame right after the MAP reception, it does not depend on the ANCH position.
	Level 1	MS can complete its processing within 1 TDMA slot (625 us), then transmit data in the UL TDMA slot.
	Level 2	MS cannot complete its processing within 1 TDMA slot but within 2 TDMA slots, then transmit data in the UL TDMA slot.
	Level 3	MS cannot complete its processing within 2 TDMA slots but within 3 TDMA slots, then transmit data in the UL TDMA slot.
↓ Low	Level 4	MS cannot complete its processing within 3 TDMA slots but within 4 TDMA slots, then transmit data in the UL TDMA slot.

The access timing is decided as shown in Table 6.2 by the processing capability of MS and the TDMA slot number of allocated ANCH. EXCH can be allocated to MS with a capability of access timing 1 based on access timing 2 when ANCH scheduling control is used as explained in Section 9.4.4.

Table 6.2 Access Timing

MS Processing Capability	The First Slot	The Second Slot	The Third Slot	The Fourth Slot
Level 0	Timing 1	Timing 1	Timing 1	Timing 1
Level 1	Timing 1	Timing 1	Timing 1	Timing 2
Level 2	Timing 1	Timing 1	Timing 2	Timing 2
Level 3	Timing 1	Timing 2	Timing 2	Timing 2
Level 4	Timing 2	Timing 2	Timing 2	Timing 2

6.4.1.1.2 Bandwidth Request by MS

When MS requests bandwidth to the BS, MS informs the transmit data size to BS using the RCH field in UL ANCH. According to the requested data size from the MS, BS reserves the bandwidth and informs bandwidth allocation through the MAP field on the DL ANCH.

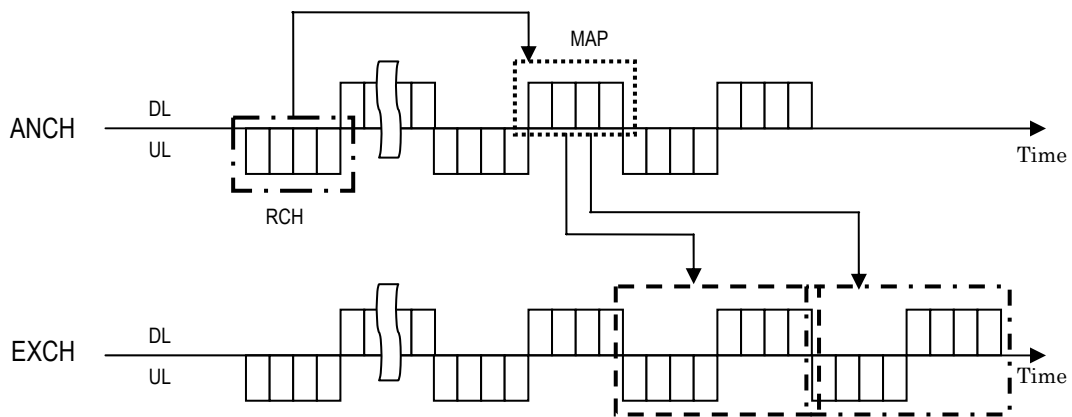

Figure 6.9 Bandwidth Allocation in Accordance with MS's Request

6.4.1.1.3 DL EXCH Holding Duration

DL EXCH will not be released during DL EXCH holding duration to avoid ANCH assignment by neighboring BSs, even when the DL EXCH is not used for information transmission. Figure 6.10 shows the relationship between the valid EXCH transmission and DL EXCH holding duration.

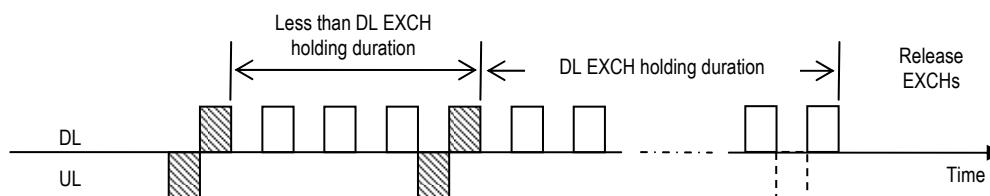

Figure 6.10 Maintenance Condition of DL EXCH

The hatched TDMA frames indicate EXCH which is used for information transfer. The plain frames indicate DL EXCH which is not used for information transfer to any MSs in active state. In these frames, BS may send idle burst on DL EXCH.

BS counts the number of frames from the last reception or transmission. When the count reaches DL EXCH holding duration, BS releases the allocated EXCH. BS will reset the count if data has been received or transmitted within DL EXCH holding duration.

6.4.1.2 Channel Selection

BS always carries out UL carrier sensing for unused PRUs in the entire bandwidth. The result of carrier sensing information will be used for channel selection.

6.4.1.2.1 Vacant PRU Judgment by UL Carrier Sensing

UL carrier sensing is carried out for UL EXCH monitoring time. Maximum value of UL carrier sensing will be used for the judgment of the vacant PRUs. UL EXCH monitoring time should be longer than DL EXCH holding duration. Based on this relationship, the neighbor BSs will avoid using the PRUs which are occupied. BS should monitor continuously for the UL EXCH monitoring time on all PRUs which the BS does not use in order to decide whether PRUs are vacant or occupied by other BSs. If the UL EXCH monitoring time is shorter than DL EXCH holding duration, then the neighbor BSs may regard a PRU which is actually occupied by EXCH, as a free PRU. Collisions will be caused if PRU is allocated to other MSs. Therefore, the UL EXCH monitoring time should be longer than the DL EXCH holding duration.

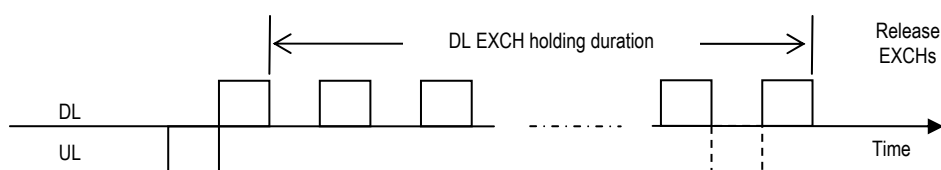

Figure 6.11 EXCH Release Timing

6.4.1.2.2 ANCH Allocation

BS allocates a vacant PRU for ANCH based on carrier sensing result when it receives "LCH assignment request" message on the UL TCCH from a MS. It then transmits "LCH assignment response" message using DL SCCH in order to inform which PRU is assigned for ANCH to the MS. The BS's decision on whether or not a PRU is vacant is made with regard to "UL RSSI threshold for ANCH selection". The MS shall measure the power level on assigned PRU when it receives "LCH assignment response" message. The state of MS will move from idle state to active state if the result of the DL carrier sensing is lower than "DL RSSI threshold for ANCH selection". The MS will send "LCH assignment re-request" message to the BS on the UL SCCH if the result of the DL carrier sensing is higher than "DL RSSI threshold for ANCH selection". When the BS receives "LCH assignment re-request" message from the MS, it will carry out the channel selection procedure except for the previously allocated PRU.

When the average SINR of a PRU is lower than "ANCH/CSCH switch DL SINR threshold" in "extension function response" message, that condition is informed to BS using CQI. Details are described in Section 8.2.5.

6.4.1.2.3 EXCH Allocation

Figure 6.12 shows information about EXCH selection. It means the transmission on selecting PRUs for EXCH. Based on the UL carrier sensing and the CQI information from the MS, BS selects PRUs and informs MS by MAP field on ANCH. The BS's decision on whether or not a PRU is vacant is made with regard to "UL RSSI threshold for EXCH selection". MS calculates

moving average of SINR, which refers to DL SINR calculation time, for each PRU assigned to the MS. CQI message is generated based on the average SINR calculated by MS.

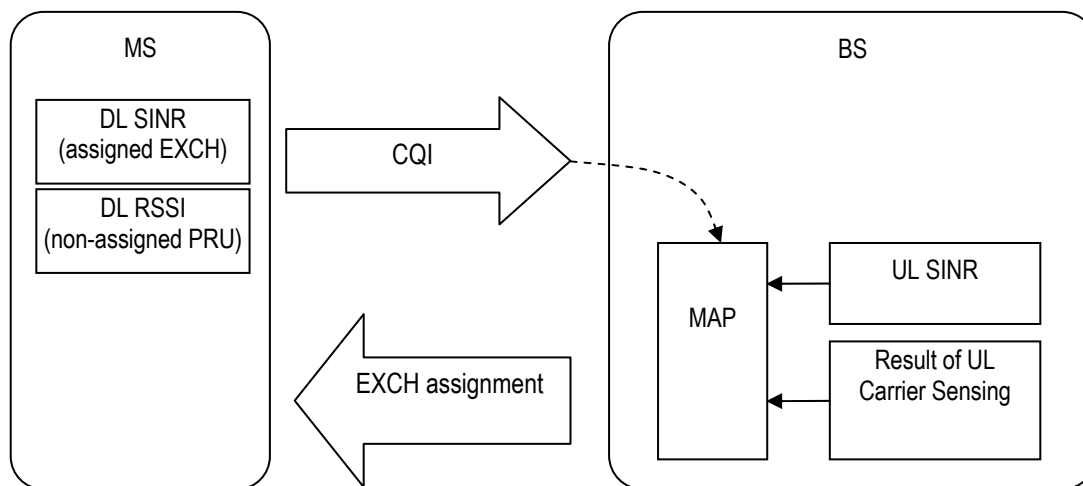

Figure 6.12 Notification of EXCH Channel Selection Information

The result of UL carrier sensing is used as the UL radio information when BS allocates vacant PRUs. Instead of allocating low-quality PRUs for the MS, BS will replace these with the higher-quality PRUs based on the CQI information. PRU, of which the UL carrier sensing result is lower than “UL RSSI threshold for EXCH selection”, is selected as a candidate PRU for allocation. PRU refused by CQI is not allocated by BS for the MS.

When the vacant PRU is used, judgment of vacancy will be done by making use of result of the UL carrier sensing as shown in Section 6.4.1.2.1.

BS calculates moving average of SINR, which refers to UL SINR calculation time, for every used PRU. When BS selects active PRU, it prioritizes PRUs which have high average SINR values. The refused PRUs notified in the CQI information are excluded from the selection.

6.4.2 QS-Mode

6.4.2.1 Channel Selection

BS always carries out UL carrier sensing for unused PRUs in the entire bandwidth. The result of carrier sensing information will be used for channel selection.

6.4.2.1.1 CSCH Allocation

When BS receives “LCH assignment request” message from the MS on the UL TCCH, it will allocate a vacant PRU and sends “LCH assignment response” message to MS on DL SCCH. The BS’s decision on whether or not a PRU is vacant is made with regard to “UL RSSI threshold for CSCH selection”. DL carrier sensing will be carried out on the designated PRU when MS receives

“LCH assignment response” message. If the result of the DL carrier sensing is lower than “DL RSSI threshold for CSCH selection”, the state of MS will move from idle state to active state. If the result of the DL carrier sensing is higher than “DL RSSI threshold for CSCH selection”, the MS will send “LCH assignment re-request” message to the BS on the UL SCCH. BS will carry out the channel selection procedure except for the previously allocated PRU when the BS receives “LCH assignment re-request” message.

When the average SINR of a PRU is lower than “ANCH/CSCH switch DL SINR threshold” in “extension function response” message, that condition is informed to BS by CQI. Details are described in Section 8.2.5.

6.5 Radio State Management

Figure 6.13 describes the radio states of MS. MS has three states. They are idle state, active state and sleep state.

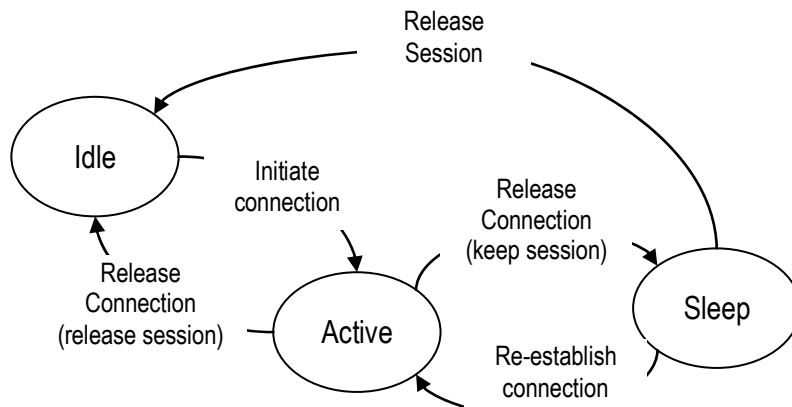

Figure 6.13 State Transition of MS

Table 6.3 States of MS

State Name	Radio Connection State	QCS State	State of MS
Idle	Nothing	Nothing	MS is waiting for paging messages.
Active	One or more	One or more	Data exchange with BS using ICH.
Sleep	Nothing	One or more	MS keeps QCS, but no ICH is established.

6.5.1 Idle State

Idle state is a state without radio connection and QCS.

In idle state, MS receives its own “paging” messages only on its PCH group. In time of incoming call or out-going call, MS in idle state is assigned an ICH from BS by SCCH and triggered to active state. The figure shows the sequence of an MS to move from idle state to active state.

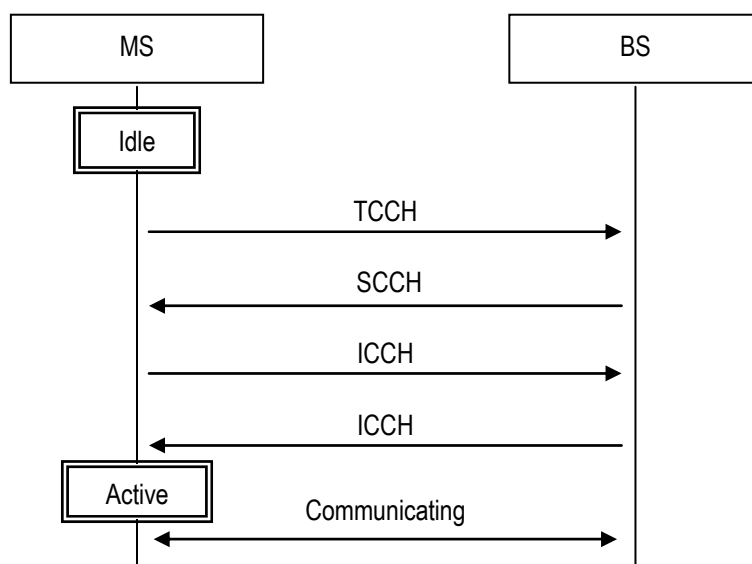

Figure 6.14 Move to Active State

MS transmits “LCH assignment request” message on TCCH to request ICH allocation. BS selects the vacant PRU from the result of the UL carrier sensing and informs the number of the allocated ICH through “LCH assignment response” message on DL SCCH. The BS’s decision on whether or not a PRU is vacant is made with regard to “UL RSSI threshold for ICCH selection”. MS carries out the DL carrier sensing on the specified PRU when it receives “LCH assignment response” message. MS will start transmission to the BS on this PRU if the result of the carrier sensing is lower than “DL RSSI threshold for ICCH selection”. Then the PRU is used as ICCH. It is considered that the radio connection between MS and BS is established when BS receives UL ICCH. MS will then perform initial radio settings to establish QCS and move itself to active state.

6.5.2 Active State

Active state is a state with one or more than one radio connections and QCSs.

In this state, MS can have one or more than one radio connections and QCSs. MS and BS can exchange data using the radio connections. BS supervises data transmission and the reception. If there is no data transmission and reception during sleep transfer time, BS releases all radio connections but holds QCS connections, and the state of MS moves to sleep state.

The change from active state to sleep is executed according to the following procedure.

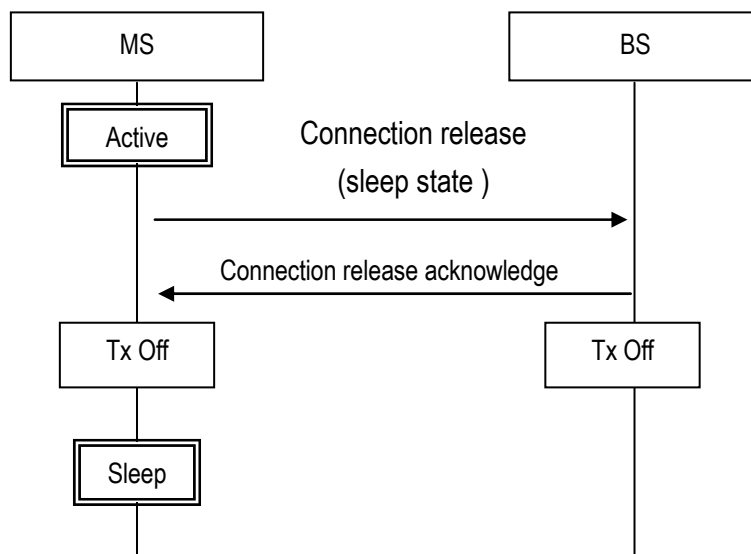

Figure 6.15 Move to Sleep State

When MS transmits UL data or receives DL data, data communication supervision timer is started. If there is data transmission or reception before timer expires, the timer will be restarted automatically. When data is not transmitted and received during sleep transfer time, data communication supervision timer will expire, and MS will send “connection release (sleep state)” message. BS transmits “connection release acknowledge” message when it receives the message. MS and BS will then release radio connection, and move to sleep state as shown in Figure 6.15.

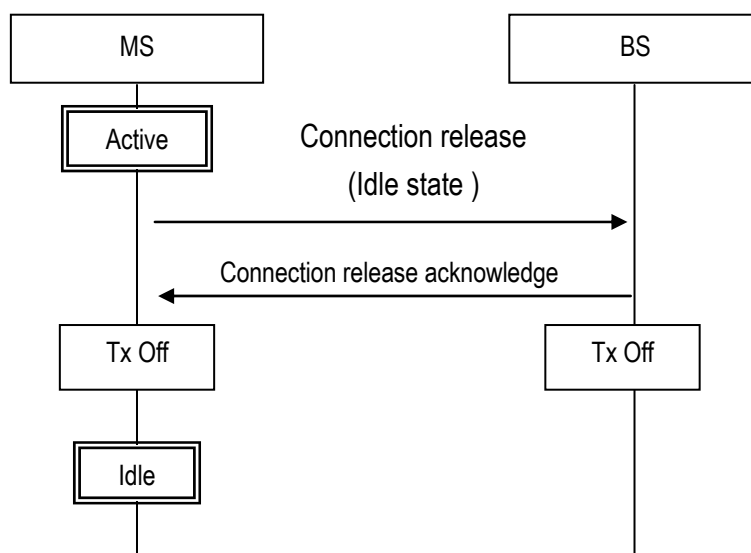

Figure 6.16 Move to Idle State

MS releases radio connection and QCS by “connection release (Idle state)” message when MS in active state has no data to exchange and it becomes unnecessary to maintain radio connection. MS will then move to idle state as shown in Figure 6.16.

6.5.3 Sleep State

Sleep state is a state which does not have radio connection but has QCS. There is connection information between the BS and MS, despite that radio connection will be released. MS receives “paging” messages on PCH in sleep state. MS then transmits “LCH assignment request” message on TCCH to request ICH allocation. After MS re-establishes radio connection to BS and recovers QCS connection, it will move to active state and communication will be restarted.

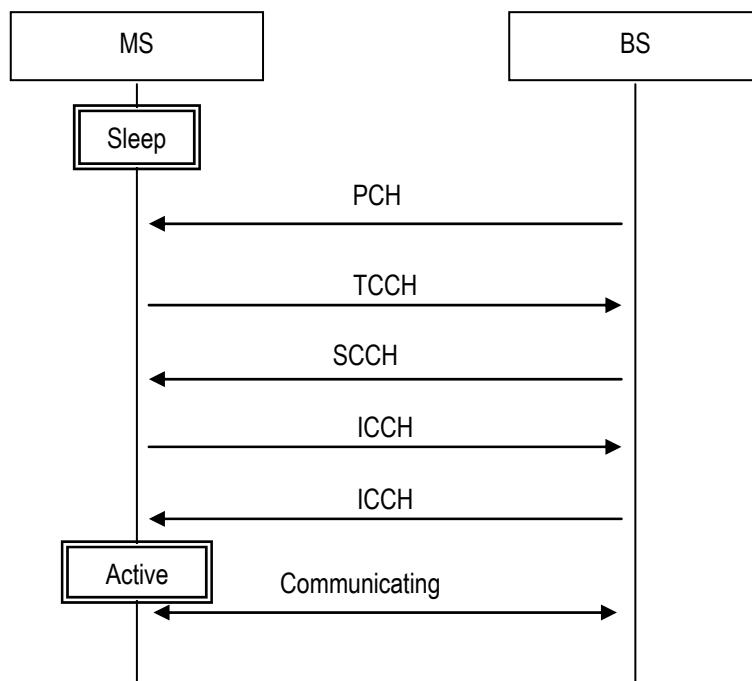

Figure 6.17 Recovery from Sleep State by DL Data Generation

When it becomes unnecessary for MS to maintain QCS, it releases QCS and moves itself to idle state.

6.6 Summary of Parameters

Parameters used in Chapter 6 are summarized in Table 6.4 and Table 6.5.

Table 6.4 Parameters Related to Time Interval

Name	Description
UL EXCH Monitoring Time	Time interval during which BS continues UL carrier sensing preceding EXCH allocation
DL EXCH Holding Duration	Time interval during which BS holds EXCH even if the EXCH is not used for information transmission.
UL SINR Calculation Time	Time interval for which BS calculates moving average of UL SINR.
DL SINR Calculation Time	Time interval for which MS calculates moving average of DL SINR.
Sleep Transfer Time	Time interval which MS waits before moving to sleep state after the last transmission or reception took place.

Table 6.5 Parameters related to RSSI and SINR

Name	Description
UL RSSI Threshold for ANCH Selection	RSSI threshold which is compared to UL carrier sensing result preceding ANCH allocation
DL RSSI Threshold for ANCH Selection	RSSI threshold which is compared to DL carrier sensing result preceding ANCH allocation
UL RSSI Threshold for EXCH Selection	RSSI threshold which is compared to UL carrier sensing result preceding EXCH allocation
UL RSSI Threshold for CSCH Selection	RSSI threshold which is compared to UL carrier sensing result preceding CSCH allocation
DL RSSI Threshold for CSCH Selection	RSSI threshold which is compared to DL carrier sensing result preceding CSCH allocation
UL RSSI Threshold for ICCH Selection	RSSI threshold which is compared to UL carrier sensing result preceding ICCH allocation
DL RSSI Threshold for ICCH Selection	RSSI threshold which is compared to DL carrier sensing result preceding ICCH allocation
ANCH/CSCH switch UL SINR Threshold	If UL SINR is lower than this threshold, BS Origin ANCH/CSCH switch is triggered.
ANCH/CSCH switch DL SINR Threshold	If DL SINR is lower than this threshold, MS Origin ANCH/CSCH switch is triggered.

Chapter 7 Message Format and Information Elements

7.1 Overview

In this chapter, message formats in the access establishment phase after link assignment phase are described. Information elements for each message are also defined. These messages are transmitted or received on function channel such as ICCH, ACCH, EDCH or CDCH and the messages are mapped on MAC payload.

7.2 Message Format

7.2.1 Format Regulations

Figure 7.1 shows the basic message format. The protocol identifier is shown in the first octet, and message type is shown in the second octet. Message information are assigned from the 3rd octet. These message information are described in Section 7.3.

The protocol identifier is defined in Section 4.4.4. Table 7.1 shows the protocol identifier, which is defined as access establishment phase control.

Moreover, information element in message is shown as M or O. M is used in mandatory case in the message. O is used in optional case in the message.

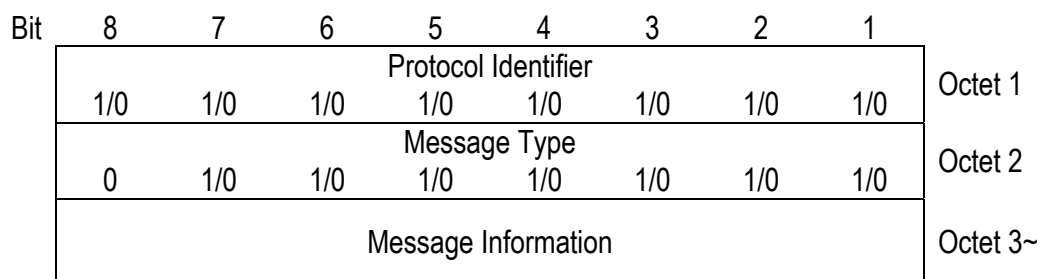

Figure 7.1 Message Format

Table 7.1 Protocol Identifier

Protocol Type	Protocol Identifier								
	Bit	8	7	6	5	4	3	2	1
Access Establishment Phase Control		0	0	0	0	0	0	1	0

7.2.2 Message Type

Table 7.2 shows the message types.

Table 7.2 Message Type List

Message Name	Reference	Message Type Bit Assign							
		8	7	6	5	4	3	2	1
Link Setup Request	7.2.2.1	0	0	0	0	0	0	0	1
Link Setup Response	7.2.2.3	0	0	0	0	0	0	1	0
Extension Function Request	7.2.2.4	0	0	0	0	0	0	1	1
Extension Function Response	7.2.2.5	0	0	0	0	0	1	0	0
Link Setup Request (SC)	7.2.2.2	0	0	0	0	0	1	0	1
Connection Request	7.2.2.6	0	0	0	0	1	0	0	0
Connection Response	7.2.2.7	0	0	0	0	1	0	0	1
ANCH/CSCH Switching Confirmation	7.2.2.8	0	0	1	0	0	0	0	0
ANCH/CSCH Switching Indication	7.2.2.9	0	0	1	0	0	0	0	1
ANCH/CSCH Switching Request	7.2.2.10	0	0	1	0	0	0	1	0
ANCH/CSCH Switching Rejection	7.2.2.11	0	0	1	0	0	0	1	1
ANCH/CSCH Switching Re-request	7.2.2.12	0	0	1	0	0	1	0	0
TDMA Slot Limitation Request	7.2.2.13	0	0	1	0	0	1	0	1
Additional LCH Confirmation	7.2.2.16	0	0	1	0	0	1	1	0
Additional LCH Indication	7.2.2.17	0	0	1	0	0	1	1	1
Additional QCS Request	7.2.2.18	0	0	1	0	1	0	0	0
Additional QCS Request Indication	7.2.2.19	0	0	1	0	1	0	0	1
Additional QCS Response	7.2.2.20	0	0	1	0	1	0	1	0
Additional QCS Rejection	7.2.2.21	0	0	1	0	1	0	1	1
Additional QCS Re-request	7.2.2.22	0	0	1	0	1	1	0	0
Connection Release	7.2.2.23	0	1	0	0	0	0	0	0
Connection Release Acknowledgement	7.2.2.24	0	1	0	0	0	0	0	1
QCS Release	7.2.2.25	0	1	0	0	0	0	1	0
QCS Release Acknowledgement	7.2.2.26	0	1	0	0	0	0	1	1
Authentication Information (1)	7.2.2.27	0	1	1	0	0	0	0	0
Authentication Information (2)	7.2.2.28	0	1	1	0	0	0	0	1
CQI Report	7.2.2.14	0	1	1	0	0	0	1	0
CQI Report Indication	7.2.2.15	0	1	1	0	0	0	1	1
Encryption Key Indication	7.2.2.29	0	1	1	0	0	1	0	0
QCS Status Enquiry Response	7.2.2.30	0	1	1	0	0	1	0	1
QCS Status Enquiry Request	7.2.2.31	0	1	1	0	0	1	1	0

7.2.2.1 Link Setup Request

This message is used for confirmation of BS assigned channel and notification of MSID. In addition, MS may notify channel type, and MS performance according to the requirement of network. (Note 1) This message is used in only OFDM mode.

Table 7.3 Link Setup Request Message Contents

Message Type : Link Setup Request
Significance : Local
Direction : UL
Function Channel : ICCH

Information Element	Reference	Direction	Type	Length	Remark
Protocol Identifier	7.2.1	UL	M	1	
Message Type	7.2.2	UL	M	1	
MSID	7.3.3.13	UL	M	6~9	
Protocol Version	7.3.3.14	UL	M	3	
Extension Function Sequence	7.3.2.3	UL	M	1	
Channel Type	7.3.2.1	UL	O	1	(Note 2)(Note 3)
MS Performance	7.3.3.12	UL	O	11	(Note 3)
Extension Function Number	7.3.3.11	UL	O	3	(Note 3)

(Note 1) This message is not recommended to be transmitted dividedly in the MAC layer. The option information element that cannot be transmitted by "Link setup request" message should be send by "Extension function request" message.

(Note 2) MS notifies the available physical channel type for itself. BS notifies the physical channel actually assigned for the communication.

(Note 3) It is necessary to specify the execution of sequence by "extension function request" message, when it is impossible for data to be transmitted by "link setup request" message.

7.2.2.2 Link Setup Request (SC)

This message is used for confirmation of BS assigned channel and notification of MSID. This message is used in SC mode. Response message for the Link Setup Request (SC) is same as OFDM.

Table 7.4 Link Setup Request (SC) Message Contents

Message Type : Link Setup Request (SC)
 Significance : Local
 Direction : UL
 Function Channel : ICCH

Information Element	Reference	Direction	Type	Length	Remark
Protocol Identifier	7.2.1	UL	M	1	
Message Type	7.2.2	UL	M	1	
MSID (SC)	7.3.3.23	UL	M	5/6/8	

7.2.2.3 Link Setup Response

This message is used for confirmation of channel type, communication parameter, etc.

Table 7.5 Link Setup Response Message Contents

Message Type : Link Setup Response
 Significance : Local
 Direction : DL
 Function Channel : ICCH

Information Element	Reference	Direction	Type	Length	Remark
Protocol Identifier	7.2.1	DL	M	1	
Message Type	7.2.2	DL	M	1	
MSID	7.3.3.13	DL	M	6~9	
Protocol Version	7.3.3.14	DL	M	3	
Extension Function Sequence	7.3.2.3	DL	M	1	
Channel Type	7.3.2.1	DL	O	1	(Note 1)
Communication Parameter	7.3.3.6	DL	O	11	(Note 2)

(Note 1) BS responds indispensably when channel type is transmitted with "link setup request" message.

(Note 2) BS responds indispensably when MS performance is transmitted with "link setup request" message.

7.2.2.4 Extension Function Request

This message is used for request of extension function.

Table 7.6 Extension Function Request Message Contents

Message Type : Extension Function Request
Significance : Local
Direction : UL
Function Channel : ICCH

Information Element	Reference	Direction	Type	Length	Remark
Protocol Identifier	7.2.1	UL	M	1	
Message Type	7.2.2	UL	M	1	
Channel Type	7.3.2.1	UL	O	1	(Note 1)
MS Performance	7.3.3.12	UL	O	11	(Note 1)
Extension Function Number	7.3.3.11	UL	O	3	(Note 1)
Source BS-info	7.3.3.20	UL	O	7	(Note 2)
Power Report	7.3.3.24	UL	O	3	

(Note 1) MS is indispensably transmitted when not transmitting with "link setup request" message.

(Note 2) When channel type shows handover, MS is indispensably transmitted.

7.2.2.5 Extension Function Response

This message is used for notification of area Information and notification of CCH superframe configuration.

Table 7.7 Extension Function Response Message Contents

Message Type : Extension Function Response
Significance : Local
Direction : DL
Function Channel : ICCH

Information Element	Reference	Direction	Type	Length	Remark
Protocol Identifier	7.2.1	DL	M	1	
Message Type	7.2.2	DL	M	1	
Channel Type	7.3.2.1	DL	O	1	(Note 1)

Communication Parameter	7.3.3.6	DL	O	11	(Note 2)
CCH Superframe Configuration	7.3.3.5	DL	O	13	(Note 3)
Area Information	7.3.3.1	DL	O	10	(Note 4)

(Note 1) BS responds indispensably when channel type is transmitted with “extension function request” message.

(Note 2) BS responds indispensably when MS performance is transmitted with “extension function request” message.

(Note 3) Only when global definition information pattern sent by MS and global definition information pattern maintained by BS is different, data is transmitted by BS.

(Note 4) Only when area information status number sent by MS and area information status number maintained by BS is different, data is transmitted by BS.

7.2.2.6 Connection Request

This message is used for notification of QoS, notification of connection type, etc.

Table 7.8 Connection Request Message Contents

Message Type : Connection Request
Significance : Local
Direction : UL
Function Channel : ICCH/EDCH/CDCH/ACCH

Information Element	Reference	Direction	Type	Length	Remark
Protocol Identifier	7.2.1	UL	M	1	
Message Type	7.2.2	UL	M	1	
Connection Type	7.3.2.2	UL	M	1	
Authentication Information 2	7.3.3.3	UL	O	3~	(Note 1)
QoS	7.3.3.17	UL	O	3	(Note 2)
QCS Information	7.3.3.16	UL	O	4	(Note 3)
Power Report	7.3.3.24	UL	O	3	
QCS Status	7.3.3.18	UL	O	4~34	(Note 4)

(Note 1) In case of handover or sleep restoration, this information element is mandatory.

(Note 2) In case of outgoing call, this information element is mandatory, otherwise omitted.

(Note 3) In case of handover or sleep restoration, this information element is mandatory, otherwise omitted.

(Note 4) In case of handover or sleep restoration, this information element is mandatory, otherwise omitted or only specifies QCSID 1.

7.2.2.7 Connection Response

This message is used for notification of QoS and connection-ID.

Table 7.9 Connection Response Message Contents

Message Type : Connection Response
Significance : Local
Direction : DL
Function Channel : ICCH/EDCH/CDCH/ACCH

Information Element	Reference	Direction	Type	Length	Remark
Protocol Identifier	7.2.1	DL	M	1	
Message Type	7.2.2	DL	M	1	
QCS Information	7.3.3.16	DL	O	4	(Note 1) (Note 4)
Connection-ID	7.3.3.7	DL	O	3	(Note 1)
Authentication Information 1	7.3.3.2	DL	O	3~	(Note 3)
QCS Status	7.3.3.18	DL	O	4~34	(Note 5)
Result of Location Registration	7.3.2.4	DL	O	1	(Note 2)
Cause	7.3.3.4	DL	O	4	(Note 1)
MSID	7.3.3.13	DL	O	6~9	(Note 6)

(Note 1) Connection is disconnected when connection-ID and QCS information is omitted. At this time, the cause of disconnection will be shown as no connection-ID or no QCS information.

(Note 2) Result of location registration is mandatory when connection type in "connection request" message is location registration or outgoing call with location registration

(Note 3) In case of handover or sleep restoration, this information element is mandatory.

(Note 4) In case of outgoing call, handover or sleep restoration, this information element is mandatory.

(Note 5) In case of handover or sleep restoration, this information element is mandatory, In case of outgoing call omitted or only specifies QCSID 1, otherwise (=location registration) omitted.

(Note 6) This information element is used to indicate temporary ID value. If this is set in Connection Response message, MS shall set the value in both this information element and MSID field in SCCH afterwards. Note that the value used for scrambling shall be available at the next transmission timing of LCH Request message.

7.2.2.8 ANCH/CSCH Switching Confirmation

This message is used for notification that MS has received “ANCH/CSCH switching indication” message.

Table 7.10 ANCH/CSCH Switching Confirmation Message Contents

Message Type : ANCH/CSCH Switching Confirmation
Significance : Local
Direction : UL
Function Channel : ICCH/EDCH/CDCH/ACCH

Information Element	Reference	Direction	Type	Length	Remark
Protocol Identifier	7.2.1	UL	M	1	
Message Type	7.2.2	UL	M	1	
Scheduling Information	7.3.3.19	UL	O	5	(Note)

(Note) This information element is omitted when scheduling term in scheduling information shows one TDMA frame.

7.2.2.9 ANCH/CSCH Switching Indication

This message is used for request of handover or switching channel from BS to MS.

Table 7.11 ANCH/CSCH Switching Indication Message Contents

Message Type : ANCH/CSCH Switching Indication
Significance : Local
Direction : DL
Function Channel : ICCH/EDCH/CDCH/ACCH

Information Element	Reference	Direction	Type	Length	Remark
Protocol Identifier	7.2.1	DL	M	1	
Message Type	7.2.2	DL	M	1	
PRU Information	7.3.3.15	DL	O	4	(Note 1)
Scheduling Information	7.3.3.19	DL	O	5	(Note 2)
Connection-ID	7.3.3.7	DL	O	3	(Note 3)

(Note 1) This information element is omitted when the message is sent as handover indication.

(Note 2) Scheduling term is considered to be one TDMA frame when the scheduling information is omitted.

(Note 3) The Connection-ID is specified when the QCS of switched channel is specified. The message is transmitted by switching the PRU when the connection-ID is omitted.

7.2.2.10 ANCH/CSCH Switching Request

This message is used for request of handover or switching channel from MS to BS.

Table 7.12 ANCH/CSCH Switching Request Message Contents

Message Type : ANCH/CSCH Switching Request

Significance : Local

Direction : UL

Function Channel : ICCH/EDCH/CDCH/ACCH

Information Element	Reference	Direction	Type	Length	Remark
Protocol Identifier	7.2.1	UL	M	1	
Message Type	7.2.2	UL	M	1	
Cause	7.3.3.4	UL	M	4	
Connection-ID	7.3.3.7	UL	O	3	(Note 1)
Target BS-info	7.3.3.21	UL	O	7	(Note 2)

(Note 1) The connection-ID is specified when the QCS of switched channel is specified. The message is transmitted by switching the PRU when the connection-ID is omitted.

(Note 2) MS notifies target BS-info by this information element when target BS is determined.

7.2.2.11 ANCH/CSCH Switching Rejection

This message is used to refuse request of ANCH/CSCH switching.

Table 7.13 ANCH/CSCH Switching Rejection Message Contents

Message Type : ANCH/CSCH Switching Rejection

Significance : Local

Direction : DL

Function Channel : ICCH/EDCH/CDCH/ACCH

Information Element	Reference	Direction	Type	Length	Remark
Protocol Identifier	7.2.1	DL	M	1	

Message Type	7.2.2	DL	M	1	
Cause	7.3.3.4	DL	M	4	

7.2.2.12 ANCH/CSCH Switching Re-request

This message is used for re-request of handover or switching channel from MS to BS, when MS has rejected ANCH/CSCH switching indication from BS.

Table 7.14 ANCH/CSCH Switching Re-request Message Contents

Message Type : ANCH/CSCH Switching Re-request
Significance : Local
Direction : UL
Function Channel : ICCH/EDCH/CDCH/ACCH

Information Element	Reference	Direction	Type	Length	Remark
Protocol Identifier	7.2.1	UL	M	1	
Message Type	7.2.2	UL	M	1	
Cause	7.3.3.4	UL	M	4	
Connection-ID	7.3.3.7	UL	O	3	(Note 1)
Target BS-info	7.3.3.21	UL	O	7	(Note 2)

(Note 1) The connection-ID is specified when the QCS of switched channel is specified. The message is transmitted by switching the PRU when the connection-ID is omitted.

(Note 2) MS notifies target BS-info by this information element when target BS is determined.

7.2.2.13 TDMA Slot Limitation Request

This message is used when MS requests a specific slot to be assigned.

Table 7.15 TDMA Slot Limitation Request Message Contents

Message Type : TDMA Slot Limitation Request
Significance : Local
Direction : UL
Function Channel : ICCH/EDCH/CDCH/ACCH

Information Element	Reference	Direction	Type	Length	Remark
Protocol Identifier	7.2.1	UL	M	1	

Message Type	7.2.2	UL	M	1	
TDMA Slot Specification	7.3.2.5	UL	M	1	

7.2.2.14 CQI Report

This message is used to send CQI data that MS measures to BS.

Table 7.16 CQI Report Message Contents

Message Type : CQI Report
Significance : Local
Direction : UL
Function Channel : ICCH/EDCH/CDCH/ACCH

Information Element	Reference	Direction	Type	Length	Remark
Protocol Identifier	7.2.1	UL	M	1	
Message Type	7.2.2	UL	M	1	
CQI	7.3.3.8	UL	O	12	
Power Report	7.3.3.24	UL	O	3	

7.2.2.15 CQI Report Indication

This message is used to direct the transmission of CQI.

Table 7.17 CQI Report Indication Message Contents

Message Type : CQI Report Indication
Significance : Local
Direction : DL
Function Channel : ICCH/EDCH/CDCH/ACCH

Information Element	Reference	Direction	Type	Length	Remark
Protocol Identifier	7.2.1	DL	M	1	
Message Type	7.2.2	DL	M	1	
Map Origin	7.3.3.22	DL	O	3	
Report Indication	7.3.3.25	DL	O	3	

7.2.2.16 Additional LCH Confirmation

This message is used to notify that assigned channel is available for communication.

Table 7.18 Additional LCH Confirmation Message Contents

Message Type : Additional LCH Confirmation
Significance : Local
Direction : UL
Function Channel : ICCH/EDCH/CDCH/ACCH

Information Element	Reference	Direction	Type	Length	Remark
Protocol Identifier	7.2.1	UL	M	1	
Message Type	7.2.2	UL	M	1	

7.2.2.17 Additional LCH Indication

This message is used for notification of channel type and PRU information at adding connection-ID.

Table 7.19 Additional LCH Indication Message Contents

Message Type : Additional LCH Indication
Significance : Local
Direction : DL
Function Channel : ICCH/EDCH/CDCH/ACCH

Information Element	Reference	Direction	Type	Length	Remark
Protocol Identifier	7.2.1	DL	M	1	
Message Type	7.2.2	DL	M	1	
PRU Information	7.3.3.15	DL	M	4	
Channel type	7.3.2.1	DL	M	1	

7.2.2.18 Additional QCS Request

This message is used to request additional QoS.

Table 7.20 Additional QCS Request Message Contents

Message Type : Additional QCS Request
 Significance : Local
 Direction : UL
 Function Channel : ICCH/EDCH/CDCH/ACCH

Information Element	Reference	Direction	Type	Length	Remark
Protocol Identifier	7.2.1	UL	M	1	
Message Type	7.2.2	UL	M	1	
QoS	7.3.3.17	UL	O	3	
QCS Information	7.3.3.16	UL	O	4	
Connection type	7.3.2.2	UL	M	1	

7.2.2.19 Additional QCS Request Indication

This message is used to direct MS to send "additional QCS request" message.

Table 7.21 Additional QCS Request Indication Message Contents

Message Type : Additional QCS Request Indication
 Significance : Local
 Direction : DL
 Function Channel : ICCH/EDCH/CDCH/ACCH

Information Element	Reference	Direction	Type	Length	Remark
Protocol Identifier	7.2.1	DL	M	1	
Message Type	7.2.2	DL	M	1	
QoS	7.3.3.17	DL	O	3	
QCS Information	7.3.3.16	DL	O	4	
Connection Type	7.3.2.2	DL	M	1	

7.2.2.20 Additional QCS Response

This message is used for notification of QCS information, Connection-ID etc.

Table 7.22 Additional QCS Response Message Contents

Message Type : Additional QCS Response
 Significance : Local
 Direction : DL

Function Channel : ICCH/EDCH/CDCH/ACCH

Information Element	Reference	Direction	Type	Length	Remark
Protocol Identifier	7.2.1	DL	M	1	
Message Type	7.2.2	DL	M	1	
QCS Information	7.3.3.16	DL	O	4	
Connection-ID	7.3.3.7	DL	O	3	(Note)
QCS Status	7.3.3.18	DL	M	4~34	

(Note) When the additional LCH is unnecessary, connection-ID is omitted.

7.2.2.21 Additional QCS Rejection

This message is used to reject additional QoS.

Table 7.23 Additional QCS Rejection Message Contents

Message Type : Additional QCS Rejection
Significance : Local
Direction : DL
Function Channel : ICCH/EDCH/CDCH/ACCH

Information Element	Reference	Direction	Type	Length	Remark
Protocol Identifier	7.2.1	DL	M	1	
Message Type	7.2.2	DL	M	1	
Cause	7.3.3.4	DL	M	4	

7.2.2.22 Additional QCS Re-request

This message is used for re-request of extra QCS, when MS has rejected "additional LCH indication" message from BS.

Table 7.24 Additional QCS Re-request Message Contents

Message Type : Additional QCS Re-request
Significance : Local
Direction : UL
Function Channel : ICCH/EDCH/CDCH/ACCH

Information Element	Reference	Direction	Type	Length	Remark
Protocol Identifier	7.2.1	UL	M	1	
Message Type	7.2.2	UL	M	1	
Cause	7.3.3.4	UL	M	4	

7.2.2.23 Connection Release

This message is used to release connection-ID. It is also used to make connection-ID a sleep state in addition.

Table 7.25 Connection Release Message Contents

Message Type : Connection Release
Significance : Local
Direction : Both
Function Channel : ICCH/EDCH/CDCH/ACCH

Information Element	Reference	Direction	Type	Length	Remark
Protocol Identifier	7.2.1	Both	M	1	
Message Type	7.2.2	Both	M	1	
Disconnection Type	7.3.3.9	Both	M	3~*	
Cause	7.3.3.4	Both	O	4	
MSID	7.3.3.13	DL	O	6~9	(Note)

(Note) This information element is used to indicate temporary ID value. If this is set in Connection Release message, MS shall set the value in both this information element and MSID field in SCCH afterwards. Note that the value used for scrambling shall be available at the next transmission timing of LCH Request message.

7.2.2.24 Connection Release Acknowledgement

This message is used to confirm release connection and the state of QoS.

Table 7.26 Connection Release Acknowledgement Message Contents

Message Type : Connection Release Acknowledgement
Significance : Local
Direction : Both
Function Channel : ICCH/EDCH/CDCH/ACCH

Information Element	Reference	Direction	Type	Length	Remark
Protocol Identifier	7.2.1	Both	M	1	
Message Type	7.2.2	Both	M	1	
QCS Status	7.3.3.18	Both	M	4~34	
MSID	7.3.3.13	DL	O	6~9	(Note)

(Note) This information element is used to indicate temporary ID value. If this is set in Connection Release Acknowledge message, MS shall set the value in both this information element and MSID field in SCCH afterwards. Note that the value used for scrambling shall be available at the next transmission timing of LCH Request message.

7.2.2.25 QCS Release

This message is used to release QCS.

Table 7.27 QCS Release Message Contents

Message Type : QCS Release
Significance : Local
Direction : Both
Function Channel : ICCH/EDCH/CDCH/ACCH

Information Element	Reference	Direction	Type	Length	Remark
Protocol Identifier	7.2.1	Both	M	1	
Message Type	7.2.2	Both	M	1	
QCS Information	7.3.3.16	Both	M	4	
Cause	7.3.3.4	Both	O	4	

7.2.2.26 QCS Release Acknowledgement

This message is used to confirm release of QCS, and the state of QoS.

Table 7.28 QCS Release Acknowledgement Message Contents

Message Type : QCS Release Acknowledgement
Significance : Local
Direction : Both
Function Channel : ICCH/EDCH/CDCH/ACCH

Information Element	Reference	Direction	Type	Length	Remark
Protocol Identifier	7.2.1	Both	M	1	
Message Type	7.2.2	Both	M	1	
QCS Status	7.3.3.18	Both	M	4~34	

7.2.2.27 Authentication Information 1

This message is used to authenticate MS.

Table 7.29 Authentication Information 1 Message Contents

Message Type : Authentication Information 1
Significance : Local
Direction : DL
Function Channel : ICCH/EDCH/CDCH/ACCH

Information Element	Reference	Direction	Type	Length	Remark
Protocol Identifier	7.2.1	DL	M	1	
Message Type	7.2.2	DL	M	1	
Authentication Information 1	7.3.3.2	DL	M	3~*	

7.2.2.28 Authentication Information 2

This message is used to authenticate MS.

Table 7.30 Authentication Information 2 Message Contents

Message Type : Authentication Information 2
Significance : Local
Direction : UL
Function Channel : ICCH/EDCH/CDCH/ACCH

Information Element	Reference	Direction	Type	Length	Remark
Protocol Identifier	7.2.1	UL	M	1	
Message Type	7.2.2	UL	M	1	
Authentication Information 2	7.3.3.3	UL	M	3~*	

7.2.2.29 Encryption Key Indication

This message is used to transmit encryption key to MS.

Table 7.31 Encryption Key Indication Message Contents

Message Type : Encryption Key Indication
Significance : Local
Direction : DL
Function Channel : ICCH/EDCH/CDCH/ACCH

Information Element	Reference	Direction	Type	Length	Remark
Protocol Identifier	7.2.1	DL	M	1	
Message Type	7.2.2	DL	M	1	
Encryption Key Set	7.3.3.10	DL	O	3~*	
Encryption Key Information	7.3.3.26	DL	O	6	

7.2.2.30 QCS Status Enquiry Response

This message is used to notify its own status of QCS or as a response to “QCS status enquiry request” message.

Table 7.32 QCS Status Enquiry Response Message Contents

Message Type : QCS Status Enquiry Response
Significance : Local
Direction : Both
Function Channel : ICCH/EDCH/CDCH/ACCH

Information Element	Reference	Direction	Type	Length	Remark
Protocol Identifier	7.2.1	Both	M	1	
Message Type	7.2.2	Both	M	1	
QCS Status	7.3.3.18	Both	M	4~34	
Cause	7.3.3.4	Both	O	4	

7.2.2.31 QCS Status Enquiry Request

This message is used to confirm QCS status. Response to the transmission of “QCS status enquiry response” message will be mandatory if this message is received.

Table 7.33 QCS Status Enquiry Request Message Contents

Message Type : QCS Status Enquiry Request
 Significance : Local
 Direction : Both
 Function Channel : ICCH/EDCH/CDCH/ACCH

Information Element	Reference	Direction	Type	Length	Remark
Protocol Identifier	7.2.1	Both	M	1	
Message Type	7.2.2	Both	M	1	
QCS Status	7.3.3.18	Both	M	4~34	

7.3 Information Element Format

7.3.1 Format Regulations

The Bit 1 is considered single octet information element, while the Bit 0 is considered multiple octet information elements.

Figure 7.2 shows the single octet information element format. The information element identifier is shown in the Bit 7~5, and information element contents are shown Bit 4~1.

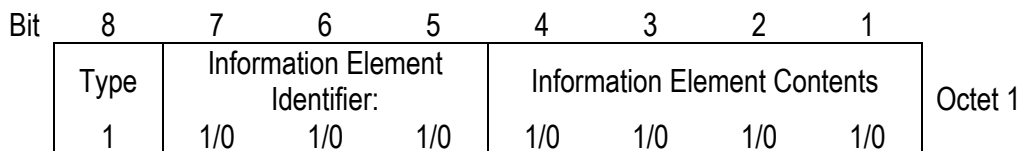

Figure 7.2 Single Octet Information Element Format

Figure 7.3 shows the multiple octet information element format. The information element identifier is shown in Octet 1, and the length of the information contents is shown in Octet 2. The information contents are assigned from Octet 3 on.

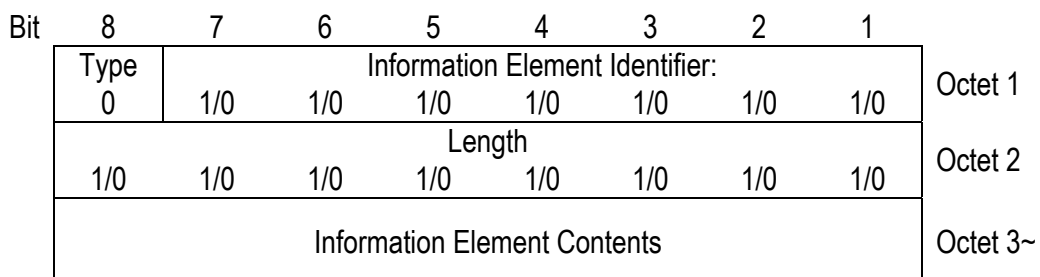

Figure 7.3 Multiple Octet Information Element Format

7.3.2 Single Octet Information Element Identifier

Table 7.34 shows the single octet information element identifiers.

Table 7.34 Single Octet Information Element Identifier List

Information Name	Information Identifier							
	Bit 8	7	6	5	4	3	2	1
Channel Type	1	0	0	1	-	-	-	-
Connection Type	1	0	1	0	-	-	-	-
Extension Function Sequence	1	0	1	1	-	-	-	-
Result of Location Registration	1	1	0	0	-	-	-	-
TDMA Slot Specification	1	1	0	1	-	-	-	-

7.3.2.1 Channel Type

This information element is used to notify channel type.

Octet	Bit							
	8	7	6	5	4	3	2	1
1	Type	Channel Type			Assign Channel Type	Physical Channel Type		Re-served
	1	0	0	1				

Assign Channel Type (Octet 1)

Bit

4

0 ANCH

1 CSCH

Physical Channel Type (Octet 1)

Bit

3 2

- 0/1 ANCH absent/present

0/1 - CSCH absent/present

Figure 7.4 Channel Type

7.3.2.2 Connection Type

This information element is used to notify connection type.

Octet	Bit							
	8	7	6	5	4	3	2	1
1	Type	Connection Type			Connection Type			
	1	0	1	0				

Connection Type (Octet 1)

Bit				
4	3	2	1	
0	0	0	0	Unallocated (unassigned) number
0	0	0	1	Outgoing call
0	0	1	0	Incoming call
0	0	1	1	Location registration
0	1	0	0	Handover
0	1	0	1	Restoration from sleep state
0	1	1	0	Outgoing call with location registration
Other				Reserved

Figure 7.5 Connection Type

7.3.2.3 Extension Function Sequence

This information element is used so that BS orders the start of extension function sequence to MS.

Octet	Bit							
	8	7	6	5	4	3	2	1
1	Type	Extension Function Sequence			Start Indication	Reserved		
	1	0	1	1				

Start Indication (Octet 1)

Bit	
4	
0	Extension function sequence absent
1	Extension function sequence present

Figure 7.6 Extension Function Sequence

7.3.2.4 Result of Location Registration

This information element is used to notify result of the location registration.

Octet	Bit							
	8	7	6	5	4	3	2	1
1	Type	Result of Location Registration			Result of Location Registration			
	1	1	0	0				

Result of Location Registration (Octet 1)

	Bit				
	4	3	2	1	
0	-	-	-	-	Class of retry possible
0	0	0	0	0	OK
0	0	0	0	1	NG (Network trouble)
0	0	1	0	0	NG (Temporary failure)
0	0	1	1	1	NG (Timer expired)
0	1	0	0	0	NG (Protocol error)
0	1	0	1	1	NG(Others)
1	-	-	-	-	Class of retry impossible
1	0	0	0	0	NG (User not contracted)
1	0	0	1	1	NG (Authentication error)
1	0	1	0	0	NG (Service un-implemented)
1	0	1	1	1	NG (Others)
1	1	0	0	0	NG (Call state and message mismatch)
	Other				Reserved

Figure 7.7 Result of Location Registration

7.3.2.5 TDMA Slot Specification

This information element is used to request to switch the connection of the specified slot to another slot.

Octet	Bit							
	8	7	6	5	4	3	2	1
1	Type	TDMA Slot Specification			Slot Number			
	1	1	0	1				

Slot Number (Octet 1)

Bit		Bit		
8	7	6	5	
-	-	-	0/1	TDMA Slot 1 uncontrollable / controllable
-	-	0/1	-	TDMA Slot 2 uncontrollable / controllable
-	0/1	-	-	TDMA Slot 3 uncontrollable / controllable
0/1	-	-	-	TDMA Slot 4 uncontrollable / controllable

Figure 7.8 TDMA Slot Specification

7.3.3 Multiple Octet Information Element Identifier

Table 7.35 shows the multiple octet information element identifiers.

Table 7.35 Multiple Information Element Identifier List

Information name	Information identifier									
	Bit	8	7	6	5	4	3	2	1	
Area Information		0	0	0	0	0	0	0	1	
Authentication Information 1		0	0	0	0	0	0	1	0	
Authentication Information 2		0	0	0	0	0	0	1	1	
Cause		0	0	0	0	0	1	0	0	
CCH Superframe Configuration		0	0	0	0	0	1	0	1	
Communication Parameter		0	0	0	0	0	1	1	0	
Connection-ID		0	0	0	0	0	1	1	1	
CQI		0	0	0	0	1	0	0	0	
Disconnection Type		0	0	0	0	1	0	0	1	
Encryption Key Set		0	0	0	0	1	0	1	0	
Extension Function Number		0	0	0	0	1	0	1	1	
MS Performance		0	0	0	0	1	1	0	0	
MSID		0	0	0	0	1	1	0	1	
Protocol Version		0	0	0	0	1	1	1	0	
PRU Information		0	0	0	0	1	1	1	1	
QCS Information		0	0	0	1	0	0	0	0	
QoS		0	0	0	1	0	0	0	1	
QCS Status		0	0	0	1	0	0	1	0	
Scheduling Information		0	0	0	1	0	0	1	1	
Source BS-info		0	0	0	1	0	1	0	0	
Target BS-info		0	0	0	1	0	1	0	1	
MAP Origin		0	0	0	1	0	1	1	0	
Power Report		0	0	0	1	0	1	1	1	
Report Indication		0	0	0	1	1	0	0	0	
Encryption Key Information		0	0	0	1	1	0	0	1	
Reserved		0	0	Other						
Option		0	1							

7.3.3.1 Area Information

This information element is used so that MS can judge the communication area of BS.

Octet	Bit							
	8	7	6	5	4	3	2	1
1	Area information							
	0	0	0	0	0	0	0	1
2	Area Information Content Length							
3	Standby Zone Selection Level							
4	Standby Zone Hold Level							
5	Handover Process Level							
6	Handover Destination Zone Selection Level							
7	Target BS Search Level							
8	ANCH/CSCH Switching FER Threshold Value							
9	ANCH/CSCH Switching SINR Threshold Value							
10	Area Information Status Number				Reserved			

Standby Zone Selection Level (Octet 3)

It specifies the threshold value level (CCCH) at which MS selects BS.

Bit	8	7	6	5	4	3	2	1	
	0	1	1	1	0	0	1	0	80 dBuV
				:					:
	0	1	0	0	0	0	0	0	30 dBuV
				:					:
	0	0	1	0	1	1	0	0	10 dBuV

(Note) 1 dB unit

Standby Zone Holding Level (Octet 4)

Specifies the threshold value level (CCCH) at which MS again selects BS.

Bit	8	7	6	5	4	3	2	1	
	0	1	1	1	0	0	1	0	80 dBuV
				:					:
	0	1	0	0	0	0	0	0	30 dBuV

0 0 1 0 : 1 1 0 0 : 10 dBuV
 (Note) 1 dB unit

Handover Process Level (Octet 5)

It specifies the threshold value level (ANCH/CSCH) at which MS performs handover.

Bit
 8 7 6 5 4 3 2 1
 0 1 1 1 0 0 1 0 80 dBuV
 :
 0 1 0 0 0 0 0 0 30 dBuV
 :
 0 0 1 0 1 1 0 0 10 dBuV
 (Note) 1 dB unit

Handover Destination Zone selection Level (Octet 6)

It specifies the threshold value level (C CCH) at which MS selects handover destination BS.

Bit
 8 7 6 5 4 3 2 1
 0 1 1 1 0 0 1 0 80 dBuV
 :
 0 1 0 0 0 0 0 0 30 dBuV
 :
 0 0 1 0 1 1 0 0 10 dBuV
 (Note) 1 dB unit

Target BS Searching Level (Octet 7)

It specifies the threshold value level (ANCH/CSCH) at which MS searches handover destination BS.

Bit
 8 7 6 5 4 3 2 1
 0 1 1 1 0 0 1 0 80 dBuV
 :
 0 1 0 0 0 0 0 0 30 dBuV
 :
 0 0 1 0 1 1 0 0 10 dBuV
 (Note) 1 dB unit

ANCH/CSCH Switching FER Threshold Value (Octet 8)

It specifies the number of errors of the 240 slots. And FER threshold value (ANCH/CSCH) shows the number of errors at which the channel switching function of MS is activated.

Bit								
8	7	6	5	4	3	2	1	
0	0	0	0	0	0	0	0	Number of slot errors n = 0
0	0	0	0	0	0	0	1	Number of slot errors n = 1
			:					:
1	1	1	1	0	0	0	0	Number of slot errors n = 240
			Other					Reserved

ANCH/CSCH Switching SINR Threshold Value (Octet 9)

It specifies the SINR threshold value (ANCH/CSCH) at which MS performs channel switching because of reception quality degradation.

Bit								
8	7	6	5	4	3	2	1	
1	1	1	1	0	1	1	0	SINR = -10 dB
			:					:
1	1	1	1	1	1	1	1	SINR = -1 dB
0	0	0	0	0	0	0	0	SINR = 0 dB
0	0	0	0	0	0	0	1	SINR = 1 dB
0	0	1	0	1	0	0	0	SINR = 40 dB
			Other					Reserved

Area Information Status Number (Octet 10)

It shows the status number of area information reported by this information element.

Bit			
8	7	6	
0	0	0	No Area Information
0	0	1	Status number 1
	:	:	
1	1	1	Status number 7

Figure 7.9 Area Information

7.3.3.2 Authentication Information 1

This information element is used to transmit authentication data, etc.

Octet	Bit							
	8	7	6	5	4	3	2	1
1	Authentication Information 1							
	0	0	0	0	0	0	1	0
2	Authentication Information 1 Content Length							
3~	Authentication Data 1							

(Note) The content of authentication data is not specified here.

Figure 7.10 Authentication Information 1

Authentication Data 1 (Authentication Message Type) (Octet 3)

Bit		8	7	6	5	4	3	2	1	
		0	0	0	0	0	0	0	0	Reserved
		0	0	0	0	0	0	0	1	Authentication method Request
		0	0	0	0	0	0	1	0	Authentication method Response
		0	0	0	0	0	0	1	1	Authentication method Acknowledge
		0	0	0	0	0	1	0	0	Transparent control information
		0	0	0	0	0	1	0	1	Encryption Indication
		0	0	0	0	0	1	1	0	Encryption Request
		0	0	0	0	0	1	1	1	Re-Authentication Request
										Other Reserved

7.3.3.2.1 Authentication Data 1 (Authentication method Request)

Octet	Bit							
	8	7	6	5	4	3	2	1
3	Authentication Message Type (Authentication method Request)							
	0	0	0	0	0	0	0	1

7.3.3.2.2 Authentication Data 1 (Authentication method Acknowledge)

Octet	Bit							
	8	7	6	5	4	3	2	1
3	Authentication Message Type (Authentication method Acknowledge)							
	0	0	0	0	0	0	1	1
4	Authentication method							
5	Authentication method							

Authentication method(Octet 4)

Bit	8	7	6	5	4	3	2	1	
-	-	-	-	-	-	-	-	0/1	Authentication Method 1 absent/present
-	-	-	-	-	-	-	0/1	-	Authentication Method 2 absent/present
-	-	-	-	-	0/1	-	-	-	Authentication Method 3 absent/present
				⋮					
0/1	-	-	-	-	-	-	-	-	Authentication Method 8 absent/present

Authentication method(Octet 5)

Bit	8	7	6	5	4	3	2	1	
-	-	-	-	-	-	-	-	0/1	Authentication Method 9 absent/present
-	-	-	-	-	-	-	0/1	-	Authentication Method 10 absent/present
-	-	-	-	-	0/1	-	-	-	Authentication Method 11 absent/present
				⋮					
0/1	-	-	-	-	-	-	-	-	Authentication Method 16 absent/present

(Note) BS notifies MS of authentication method.

7.3.3.2.3 Authentication Data 1 (Transparent control information)

Octet	Bit							
	8	7	6	5	4	3	2	1
3	Authentication Message Type (Transparent control information)							
	0	0	0	0	0	1	0	0
4~	Authentication Information							

Authentication Information (Octet 4~)

Authentication Information is transmitted between MS and network transparently via BS.

7.3.3.2.4 Authentication Data 1 (Encryption Indication)

Octet	Bit							
	8	7	6	5	4	3	2	1
3	Authentication Message Type (Encryption Indication)							
	0	0	0	0	0	1	0	1
4	Encryption Method							
5	Encryption Method							
6~21	Random Number							

Encryption Method (Octet 4)

Bit		8	7	6	5	4	3	2	1	
0/1	-	-	-	-	-	-	-	-	-	Encryption Method 1 absent/present
-	0/1	-	-	-	-	-	-	-	-	Encryption Method 2 absent/present
-	-	0/1	-	-	-	-	-	-	-	Encryption Method 3 absent/present
			:							
-	-	-	-	-	-	-	-	0/1	-	Encryption Method 8 absent/present

Encryption Method (Octet 5)

Bit		8	7	6	5	4	3	2	1	
0/1	-	-	-	-	-	-	-	-	-	Encryption Method 9 absent/present
-	0/1	-	-	-	-	-	-	-	-	Encryption Method 10 absent/present
-	-	0/1	-	-	-	-	-	-	-	Encryption Method 11 absent/present
			:							
-	-	-	-	-	-	-	-	0/1	-	Encryption Method 16 absent/present

Random Number (Octet 6~21)

Challenge value for challenge and response authentication check. This is a random value.

7.3.3.3 Authentication Information 2

This information element is used to transmit authentication data etc.

Octet	Bit							
	8	7	6	5	4	3	2	1
1	Authentication Information 2							
	0	0	0	0	0	0	1	1
2	Authentication Information 2 Content Length							
3~	Authentication Data 2							

(Note) The content of authentication data is not specified here.

Figure 7.11 Authentication Information 2

Authentication Data 2 (Authentication Message Type) (Octet 3)

Bit	8	7	6	5	4	3	2	1	
	0	0	0	0	0	0	0	0	Reserved
	0	0	0	0	0	0	0	1	Authentication method Request
	0	0	0	0	0	0	1	0	Authentication method Response
	0	0	0	0	0	0	1	1	Authentication method Acknowledge
	0	0	0	0	0	1	0	0	Transparent control information
	0	0	0	0	0	1	0	1	Encryption Indication
	0	0	0	0	0	1	1	0	Encryption Request
	0	0	0	0	0	1	1	1	Re-Authentication Request
	Other				Reserved				

7.3.3.3.1 Authentication Data 2 (Authentication method Response)

Octet	Bit							
	8	7	6	5	4	3	2	1
3	Authentication Message Type (Authentication method Response)							
	0	0	0	0	0	0	1	0
4	Authentication method							
5	Authentication method							

Authentication method(Octet 4)

Bit	8	7	6	5	4	3	2	1	
-	-	-	-	-	-	-	-	0/1	Authentication Method 1 absent/present
-	-	-	-	-	-	-	0/1	-	Authentication Method 2 absent/present
-	-	-	-	-	-	0/1	-	-	Authentication Method 3 absent/present
					⋮				
0/1	-	-	-	-	-	-	-	-	Authentication Method 8 absent/present

Authentication method(Octet 5)

Bit	8	7	6	5	4	3	2	1	
-	-	-	-	-	-	-	-	0/1	Authentication Method 9 absent/present
-	-	-	-	-	-	-	0/1	-	Authentication Method 10 absent/present
-	-	-	-	-	-	0/1	-	-	Authentication Method 11 absent/present
					⋮				
0/1	-	-	-	-	-	-	-	-	Authentication Method 16 absent/present

7.3.3.3.2 Authentication Data 2 (Transparent control information)

Octet	Bit	8	7	6	5	4	3	2	1
3	Authentication Message Type (Transparent control information)								
	0	0	0	0	0	1	0	0	
4~	Authentication Information								

Authentication Information (Octet 4~)

Authentication Information is transmitted between MS and network transparently via BS.

7.3.3.3.3 Authentication Data 2 (Re-Authentication Request)

Octet	Bit	8	7	6	5	4	3	2	1
3	Authentication Message Type (Re-Authentication Request)								
	0	0	0	0	0	1	1	1	

7.3.3.3.4 Authentication Data 2 (Encryption Request)

Octet	Bit							
	8	7	6	5	4	3	2	1
3	Authentication Message Type (Encryption Request)							
	0	0	0	0	0	1	1	0
4	Encryption Method							
5	Encryption Method							
6~21	Response Value							

Encryption Method (Octet 4)

Bit		8	7	6	5	4	3	2	1	
0/1	-	-	-	-	-	-	-	-	-	Encryption Method 1 absent/present
-	0/1	-	-	-	-	-	-	-	-	Encryption Method 2 absent/present
-	-	0/1	-	-	-	-	-	-	-	Encryption Method 3 absent/present
-	-	-	:	-	-	-	-	-	-	Encryption Method 4 absent/present
-	-	-	-	-	-	-	-	0/1	-	Encryption Method 8 absent/present

Encryption Method (Octet 5)

Bit		8	7	6	5	4	3	2	1	
0/1	-	-	-	-	-	-	-	-	-	Encryption Method 9 absent/present
-	0/1	-	-	-	-	-	-	-	-	Encryption Method 10 absent/present
-	-	0/1	-	-	-	-	-	-	-	Encryption Method 11 absent/present
-	-	-	:	-	-	-	-	-	-	Encryption Method 12 absent/present
-	-	-	-	-	-	-	-	0/1	-	Encryption Method 16 absent/present

Response Value (Octet 6~21)

Response value for challenge and response check.

7.3.3.4 Cause

The information element is used to describe the reason and location of message generation.

Octet	Bit							
	8	7	6	5	4	3	2	1
1	Cause							
	0	0	0	0	0	1	0	0
2	Cause Content Length							
3	Coding Standard		Location				Reserved	
4	Cause Value							Re-served

Coding Standard (Octet 3)

Bit		
8	7	
0	0	sPHS
Other	Reserved	

Location (Octet 3)

Bit				
6	5	4	3	
0	0	0	0	MS
0	0	0	1	BS
0	0	1	0	Network
0	0	1	1	Other
Other		Reserved		

Cause Value (Octet 4)

Bit								
8	7	6	5	4	3	2		
0	0	0	-	-	-	-	Normal class	
			0	0	0	0	Normal disconnect	
							Response to QCS status enquiry request	
			1	1	1	1	Others	
0	1	0	-	-	-	-	Resource busy class	
			0	0	0	1	No vacant PRU (include no slot available)	
			0	0	1	0	No available PRU	
			0	0	1	1	No route to specified transit network	
			0	1	0	0	No connection-ID	
			0	1	0	1	No QCS information	
			0	1	1	0	Equipment abnormal	
			1	1	1	1	Others	
0	1	1	-	-	-	-	Resource down class	
			0	0	0	1	Temporary failure	
			0	0	1	0	Network out of order	
			1	1	1	1	Others	
1	0	0	-	-	-	-	Service not available class	

	0	0	0	1	Requested function not responding	
	1	1	1	1	Service or option not implemented, unspecified (include no channel adding function at BS side)	
1	0	1	-	-	-	Invalid message (e.g.: Parameter out of range) class
	0	0	0	1	Assigned PRU non corresponding	
	0	0	1	0	No channel adding function	
1	1	0	-	-	-	Procedure error class
	0	0	0	1	Message abnormal	
	0	0	1	0	Information element abnormal	
	0	0	1	1	Sequence abnormal	
	0	1	0	0	Timer expiration	
	1	1	1	1	Other procedure error class	
Other					Reserved	

Figure 7.12 Cause

7.3.3.5 CCH Superframe Configuration

This information element is used to notify superframe configuration of CCH.

Octet	Bit							
	8	7	6	5	4	3	2	1
1	CCH Superframe Configuration							
	0	0	0	0	0	1	0	1
2	CCH Superframe Configuration Content Length							
3	Reserved		LCCH Interval Value n					
4	Paging Grouping Factor n_{GROUP}				Paging Area Number Length n_p			
5	Reserved		Number of Same Paging Groups n_{SG}			Battery Saving Cycle Maximum Value n_{BS}		
6	Control Carrier Structure		PCH Number n_{PCH}			Frame Basic Unit Length n_{SUB}		
7	Reserved							
8	Re-served	Broadcasting Status Indication			Global Definition Information Pattern			
9	Protocol Version							
10	Reserved			BSID Area Bit Length n_{BL}				
11	Reserved							
12	Reserved							
13	Reserved							

LCCH Interval Value n (Octet 3)

It shows the DL LCCH slot intermittent cycle.

Bit	6	5	4	3	2	1	
0	0	0	0	0	0	0	Reserved
0	0	0	0	0	0	1	n = 1
0	0	0	0	0	1	0	n = 2
0	0	0	0	0	1	1	n = 3
			:				:
0	1	0	1	0	0		n = 20
			:				:
1	1	1	1	1	1	1	n = 63

Paging Grouping Factor n_{GROUP} (Octet 4)

It shows the value of PCH information corresponding to the number of group divisions.

Bit	8	7	6	5	
0	0	0	0	0	LCCH superframe is not constructed (option)
0	0	0	0	1	$n_{GROUP} = 1$
0	0	0	1	1	$n_{GROUP} = 2$
		:			:
1	1	1	1	1	$n_{GROUP} = 15$

(Note) If LCCH is multiplexed, the values of n_{PCH} and n_{GROUP} will be set so that the paging group number does not exceed 127.

Paging Area Number Length n_p (Octet 4)

It shows the bit length of the paging area number included in BSID.

Bit	4	3	2	1	
0	0	0	0	0	Reserved
0	0	0	0	1	$n_p = 4$
0	0	0	1	0	$n_p = 6$
0	0	0	1	1	$n_p = 8$
0	1	0	0	0	$n_p = 10$
0	1	0	0	1	$n_p = 12$
0	1	0	1	0	$n_p = 13$
0	1	0	1	1	$n_p = 14$
1	0	0	0	0	$n_p = 15$
1	0	0	0	1	$n_p = 16$
1	0	0	1	0	$n_p = 17$
1	0	0	1	1	$n_p = 18$
1	1	0	0	0	$n_p = 19$
1	1	0	0	1	$n_p = 20$

Bit	4	3	2	1	
	1	1	1	0	$n_p = 21$
	1	1	1	1	$n_p = 22$

(Note 2) n_p must be the same even in a different paging area if handover between paging areas is executed.

Number of Same Paging Groups n_{SG} (Octet 5)

It shows the number of PCH slots belonging to the same paging group in the LCCH superframe.

Bit	6	5	4	
	0	0	0	LCCH superframe is not constructed (option)
	0	0	1	$n_{SG} = 1$
		:		:
	1	1	1	$n_{SG} = 7$

Battery Saving Cycle Maximum Value n_{BS} (octet 5)

It shows the times that BS continuously sends the same paging signal to the paging group.

Bit	3	2	1	
	0	0	0	LCCH superframe is not constructed (option)
	0	0	1	$n_{BS} = 1$
		:		:
	1	1	1	$n_{BS} = 7$

Control Carrier Structure (Octet 6)

It shows the presence or absence of a mutual relationship between paging group and number of LCCHs used by the relevant BS.

Bit	8	7	
	0	0	Shows that only 1 LCCH is used.
	0	1	Shows that 2 LCCHs are used, and each individual LCCH is independent.
	1	0	Shows that 2 LCCHs are used, and PCH paging groups are mutually related.
	1	1	Reserved

PCH Number n_{PCH} (Octet 6)

It shows the number of PCHs in the frame basic unit.

Bit	6	5	4	
	0	0	0	No PCH (optional)
	0	0	1	1 PCH slots in frame basic unit ($n_{PCH} = 1$)
		:		:
	1	1	1	7 PCH slots in frame basic unit ($n_{PCH} = 7$)

(Note 3) If LCCH is multiplexed, the values of n_{PCH} and n_{GROUP} will be set so that the paging group number does not exceed 127.

Frame Basic Unit Length n_{SUB} (Octet 6)

It shows the length of the LCCH superframe structural element (frame basic unit).

Bit	3	2	1	
	0	0	0	(Optional)
	0	0	1	$n_{SUB} = 1$
		:		:
	1	1	1	$n_{SUB} = 7$

Broadcasting Status Indication (Octet 8)

It shows the presence or absence of information broadcasting messages other than “radio channel information broadcasting” message sent on the relevant LCCH.

Bit	6	5	4	
	-	-	1/0	“System information broadcasting” message present / absent
	-	1/0	-	“Optional information broadcasting” message present / absent
	1/0	-	-	Reserved

Global Definition Information Pattern (Octet 8)

It shows the relevant pattern number of the present “radio channel information broadcasting” message. When “radio channel information broadcasting” message changes, the new global definition information pattern is set.

Bit	4	3	2	1	
	0	0	0	0	Global definition information pattern (0)
	0	0	0	0	Global definition information pattern (1)
	0	0	1	0	Global definition information pattern (2)
		:			:
	1	1	1	0	Global definition information pattern (7)
	Other				Reserved

Protocol Version (Octet 9)

It shows protocol version supported by BS.

Bit	8	7	6	5	4	3	2	1
	0	0	0	0	0	0	0	1/0

Version 1 present / absent
Reserved

BSID Area Bit Length n_{BL} (Octet 10)

It shows the BSID area bit length included in the BS information.

Bit	5	4	3	2	1	
	0	0	0	0	0	$n_{BL} = 15$
	0	0	0	0	1	$n_{BL} = 16$
	0	0	0	1	0	$n_{BL} = 17$
			:			:
	1	1	0	0	1	$n_{BL} = 40$

Other

Reserved

Figure 7.13 CCH Superframe Configuration

7.3.3.6 Communication Parameter

This information element is used to notify MCS, map timing etc.

Octet	Bit							
	8	7	6	5	4	3	2	1
1	Communication parameter							
	0	0	0	0	0	1	1	0
2	Communication parameter Content Length							
3	OFDM MCS for UL / SC MCS for UL							
4	OFDM MCS for UL / SC MCS for UL							
5	OFDM MCS for DL							
6	OFDM MCS for DL							
7	Map Timing	MAP Origin					Reserved	
8	EXCH Timing			Window Size			Com- bine	Re- served
9	Retransmission Times(Note)			Full Sub-carrier Mode	Error Correct Encoding			Re- served
10	HARQ Method			MIMO				
11	Reserved							

(Note) MS notifies BS the maximum value that can correspond by MS performance. BS decides the retransmission time, and indicates it by communication parameter.

OFDM MCS for UL (Octet 3)

Bit	8	7	6	5	4	3	2	1	Modulation class [Puncturing rate, Efficiency]
0/1	-	-	-	-	-	-	-	-	BPSK [1 , 0.5] absent/present
-	0/1	-	-	-	-	-	-	-	BPSK [3/4 , 0.67] absent/present
-	-	0/1	-	-	-	-	-	-	QPSK [1 , 1] absent/present
-	-	-	0/1	-	-	-	-	-	QPSK [4/6 , 1.5] absent/present
-	-	-	-	0/1	-	-	-	-	Reserved
-	-	-	-	-	0/1	-	-	-	16QAM [1 , 2] absent/present
-	-	-	-	-	-	0/1	-	-	16QAM [4/6 , 3] absent/present
-	-	-	-	-	-	-	0/1	-	64QAM [3/4 , 4] absent/present

OFDM MCS for UL (Octet 4)

Bit	8	7	6	5	4	3	2	1	
0/1	-	-	-	-	-	-	-	-	64QAM [6/10 , 5] absent/present
-	0/1	-	-	-	-	-	-	-	256QAM [4/6 , 6] absent/present
		0/1	-	-	-	-	-	-	256QAM [8/14 , 7] absent/present
			Other	-	-	-	-	-	Reserved

SC MCS for UL (Octet 3)

Bit	8	7	6	5	4	3	2	1	Modulation class [Puncturing rate, Efficiency]
0/1	-	-	-	-	-	-	-	-	$\pi/2$ - BPSK [1 , 0.5] absent/present
-	0/1	-	-	-	-	-	-	-	$\pi/2$ - BPSK [3/4 , 0.67] absent/present
-	-	0/1	-	-	-	-	-	-	$\pi/4$ - QPSK [1 , 1] absent/present
-	-	-	0/1	-	-	-	-	-	$\pi/4$ - QPSK [4/6 , 1.5] absent/present
-	-	-	-	0/1	-	-	-	-	8PSK [3/4 , 2] absent/present
-	-	-	-	-	0/1	-	-	-	16QAM [1 , 2] absent/present
-	-	-	-	-	-	0/1	-	-	16QAM [4/6 , 3] absent/present
-	-	-	-	-	-	-	0/1	-	64QAM [3/4 , 4] absent/present

SC MCS for UL (Octet 4)

Bit	8	7	6	5	4	3	2	1	
0/1	-	-	-	-	-	-	-	-	64QAM [6/10 , 5] absent/present
-	0/1	-	-	-	-	-	-	-	256QAM [4/6 , 6] absent/present
-	-	0/1	-	-	-	-	-	-	256QAM [8/14 , 7] absent/present
			Other	-	-	-	-	-	Reserved

OFDM MCS for DL (Octet 5)

Bit	8	7	6	5	4	3	2	1	Modulation class [Puncturing rate, Efficiency]
0/1	-	-	-	-	-	-	-	-	BPSK [1 , 0.5] absent/present
-	0/1	-	-	-	-	-	-	-	BPSK [3/4 , 0.67] absent/present
-	-	0/1	-	-	-	-	-	-	QPSK [1 , 1] absent/present
-	-	-	0/1	-	-	-	-	-	QPSK [4/6 , 1.5] absent/present
-	-	-	-	0/1	-	-	-	-	Reserved
-	-	-	-	-	0/1	-	-	-	16QAM [1 , 2] absent/present
-	-	-	-	-	-	0/1	-	-	16QAM [4/6 , 3] absent/present
-	-	-	-	-	-	-	0/1	-	64QAM [3/4 , 4] absent/present

OFDM MCS for DL (Octet 6)

Bit	8	7	6	5	4	3	2	1	
0/1	-	-	-	-	-	-	-	-	64QAM [6/10 , 5] absent/present

-	0/1	-	-	-	-	-	256QAM [4/6 , 6] absent/present
							256QAM [8/14 , 7] absent/present
						Other	Reserved

Map Timing (Octet 7)

Bit	
8	
0	Timing 1
1	Timing 2

Map Origin (Octet 7)

Bit					
7	6	5	4	3	
0	0	0	0	0	SCH 1
0	0	0	0	1	SCH 2
0	0	0	1	0	SCH 3
		:		:	
1	0	0	1	1	SCH 20
		Other			Reserved

EXCH Timing (Octet 8)

Bit			
8	7	6	
0	0	0	Level 0
0	0	1	Level 1
0	1	0	Level 2
0	1	1	Level 3
1	0	0	Level 4
	Other		Reserved

Window Size (Octet 8)

Bit			
5	4	3	
0	0	0	Reserved
0	0	1	Window size pattern 1
0	1	0	Window size pattern 2
	:	:	
1	1	1	Window size pattern 7

MAC Combine (Octet 8)

Bit	
2	
0	MAC Combine absent
1	MAC Combine present

Retransmission Times (Octet 9)

Bit			
8	7	6	
0	0	0	No Retransmission
0	0	1	Once
0	1	0	Twice
	:	:	
1	1	1	7 times

Full Subcarrier Mode (Octet 9)

Bit	
5	
0/1	Full Subcarrier Mode function absent / present

Error Correction Encoding (Octet 9)

Bit			
4	3	2	
0/1	-	-	Convolutional encoding (Mandatory) absent/present
-	0/1	-	Turbo coding (Optional) absent/present
-	-	0/1	Reserved

HARQ Method (Octet 10)

Bit			
8	7	6	
0/1	-	-	CC-HARQ absent/present
-	0/1	-	IR-HARQ (Optional) absent/present
-	-	0/1	Reserved

MIMO (Octet 10)

Bit					
5	4	3	2	1	
0	-	-	-	-	MIMO method 1
	0/1	-	-	-	2 by 2 MIMO (Reserved) absent / present
	-	0/1	-	-	3 by 3 MIMO (Reserved) absent / present
	-	-	0/1	-	4 by 4 MIMO (Reserved) absent / present
	-	-	-	0/1	Reserved
1	-	-	-	-	MIMO method 2
	0/1	-	-	-	2 by 2 MIMO (Reserved) absent / present
	-	0/1	-	-	3 by 3 MIMO (Reserved) absent / present
	-	-	0/1	-	4 by 4 MIMO (Reserved) absent / present
	-	-	-	0/1	Reserved

Figure 7.14 Communication Parameter

7.3.3.7 Connection-ID

This information element is used to notify connection-ID.

Octet	Bit							
	8	7	6	5	4	3	2	1
1	Connection-ID							
	0	0	0	0	0	1	1	1
2	Connection-ID Content Length							
3	Connection-ID				Reserved			

Connection-ID (Octet 3)

Bit				
8	7	6	5	
0	0	0	0	Connection-ID 1
0	0	0	1	Connection-ID 2
0	0	1	0	Connection-ID 3
:				:
1	1	1	1	Connection-ID 16

Figure 7.15 Connection-ID

7.3.3.8 CQI

This information element is used to notify the CQI to BS that is measured by MS.

Octet	Bit							
	8	7	6	5	4	3	2	1
1	CQI							
	0	0	0	0	1	0	0	0
2	CQI Content Length							
3	RMAP (MSB)							
:	:							
11	RMAP (LSB)							
12	MAP Origin				Reserved			

RMAP is the number based on MAP origin. MS notifies the status of PRU as CQI, as requested by BS. CQI information is composed of RMAP. RMAP notifies the status of PRU.

RMAP (Octet 3)

Bit	8	7	6	5	4	3	2	1	
0/1	-	-	-	-	-	-	-	-	Accept/Refuse PRU 1
-	0/1	-	-	-	-	-	-	-	Accept/Refuse PRU 2
-	-	0/1	-	-	-	-	-	-	Accept/Refuse PRU 3
-	-	-	0/1	-	-	-	-	-	Accept/Refuse PRU 4
-	-	-	-	0/1	-	-	-	-	Accept/Refuse PRU 5
-	-	-	-	-	0/1	-	-	-	Accept/Refuse PRU 6
-	-	-	-	-	-	0/1	-	-	Accept/Refuse PRU 7
-	-	-	-	-	-	-	0/1	-	Accept/Refuse PRU 8

RMAP (Octet 4)

Bit	8	7	6	5	4	3	2	1	
0/1	-	-	-	-	-	-	-	-	Accept/Refuse PRU 9
-	0/1	-	-	-	-	-	-	-	Accept/Refuse PRU 10
-	-	0/1	-	-	-	-	-	-	Accept/Refuse PRU 11
				:					:

RMAP (Octet 11)

Bit	8	7	6	5	4	3	2	1	
0/1	-	-	-	-	-	-	-	-	Accept/Refuse PRU 65
-	0/1	-	-	-	-	-	-	-	Accept/Refuse PRU 66
-	-	0/1	-	-	-	-	-	-	Accept/Refuse PRU 67
-	-	-	0/1	-	-	-	-	-	Accept/Refuse PRU 68
-	-	-	-	0/1	-	-	-	-	Accept/Refuse PRU 69
-	-	-	-	-	0/1	-	-	-	Accept/Refuse PRU 70
-	-	-	-	-	-	0/1	-	-	Accept/Refuse PRU 71
-	-	-	-	-	-	-	0/1	-	Accept/Refuse PRU 72

Map Origin (Octet 12)

Bit	8	7	6	5	4	
0	0	0	0	0	0	SCH 1
0	0	0	0	0	1	SCH 2
0	0	0	1	0	0	SCH 3
			:			:
1	0	0	1	1		SCH 20
		Other				Reserved

Figure 7.16 CQI

7.3.3.9 Disconnection Type

This information element is used to notify disconnected connection-ID, etc.

Octet	Bit							
	8	7	6	5	4	3	2	1
1	Disconnection type							
	0	0	0	0	1	0	0	1
2	Disconnection Type Content Length							
3~*	Con- tinua- tion	Connection-ID				Disconnection Type	Re- served	

Continuation (Octet 3)

Bit

8

0 Last octet

1 Continuation (Note)

(Note) When continuation is set to 1, other connection-ID and disconnection type is followed to the next octet.

Connection-ID (Octet 3)

Bit

7

6

5

4

0 0 0 0 Connection-ID 1

0 0 0 1 Connection-ID 2

0 0 1 0 Connection-ID 3

:

:

1 1 1 1 Connection-ID 16

Disconnection Type (Octet 3)

Bit

3

2

0 0 Release connection and transit to sleep state

0 1 Release connection and transit to idle state

Others Reserved

Figure 7.17 Disconnection Type

7.3.3.10 Encryption Key Set

This information element is used to report the key for performing encryption.

Octet	Bit							
	8	7	6	5	4	3	2	1
1	Encryption key set							
	0	0	0	0	1	0	1	0
2	Encryption Key Set Content Length							
3~*	Encryption Key							

Figure 7.18 Encryption Key Set

7.3.3.11 Extension Function Number

This information element is used to notify global definition information pattern and area information number.

Octet	Bit							
	8	7	6	5	4	3	2	1
1	Extension Function Number							
	0	0	0	0	1	0	1	1
2	Extension Function Number Content Length							
3	Global Definition Information Pattern				Area Information Status Number			Re-served

Global Definition Information Pattern (Octet 3)

Bit		Description
8	7 6 5	
0	0 0 0	Global definition information pattern 0
0	0 0 1	Global definition information pattern 1
	:	:
1	1 1 0	Global definition information pattern 7
	Other	Reserved

Area Information Status Number (Octet 3)

Bit		Description
4	3 2	
0	0 0	No area information
0	0 1	Area information status number 1

1 : 1 :
 1 1 1 Area information status number 7

Figure 7.19 Extension Function Number

7.3.3.12 MS Performance

This information element is used to notify MCS, EXCH timing, etc.

Octet	Bit							
	8	7	6	5	4	3	2	1
1	MS Performance							
	0	0	0	0	1	1	0	0
2	MS Performance Content Length							
3	OFDM MCS for UL / SC MCS for UL							
4	OFDM MCS for UL / SC MCS for UL							
5	OFDM MCS for DL							
6	OFDM MCS for DL							
7	EXCH Timing				Self-owned Bandwidth			
8	Synthesizer		Error Correct Encoding			RF Number		Full Sub-carrier Mode
9	HARQ Method				MIMO			
10	Window Size				Retransmission Times (Note)		Com-bine	Re-served
11	Reserved							

(Note) MS notifies BS the maximum value that can correspond by MS performance. BS decides the retransmission time, and indicates it by communication parameter.

OFDM MCS for UL (Octet 3)

Bit								Modulation class [Puncturing rate, Efficiency]
8	7	6	5	4	3	2	1	
0/1	-	-	-	-	-	-	-	BPSK [1 , 0.5] absent/present
-	0/1	-	-	-	-	-	-	BPSK [3/4 , 0.67] absent/present
-	-	0/1	-	-	-	-	-	QPSK [1 , 1] absent/present
-	-	-	0/1	-	-	-	-	QPSK [4/6 , 1.5] absent/present
-	-	-	-	0/1	-	-	-	16QAM [1 , 2] absent/present
-	-	-	-	-	0/1	-	-	16QAM [4/6 , 3] absent/present
-	-	-	-	-	-	0/1	-	64QAM [3/4 , 4] absent/present
-	-	-	-	-	-	-	0/1	64QAM [6/10 , 5] absent/present

OFDM MCS for UL (Octet 4)

Bit								Modulation class [Puncturing rate, Efficiency]	
8	7	6	5	4	3	2	1		
0/1	-	-	-	-	-	-	-	256QAM [4/6 , 6] absent/present	
-	0/1	-	-	-	-	-	-	256QAM [8/14 , 7] absent/present	
-	-	-	Other				-	-	Reserved

SC MCS for UL (Octet 3)

Bit								Modulation class [Puncturing rate, Efficiency]
8	7	6	5	4	3	2	1	
0/1	-	-	-	-	-	-	-	$\pi/2$ BPSK [1 , 0.5] absent/present
-	0/1	-	-	-	-	-	-	$\pi/2$ BPSK [3/4 , 0.67] absent/present
-	-	0/1	-	-	-	-	-	$\pi/4$ QPSK [1 , 1] absent/present
-	-	-	0/1	-	-	-	-	$\pi/4$ QPSK [4/6 , 1.5] absent/present
-	-	-	-	0/1	-	-	-	8PSK [3/4 , 2] absent/present
-	-	-	-	-	0/1	-	-	16QAM [1 , 2] absent/present
-	-	-	-	-	-	0/1	-	16QAM [4/6 , 3] absent/present
-	-	-	-	-	-	-	0/1	64QAM [3/4 , 4] absent/present

SC MCS for UL (Octet 4)

Bit								Modulation class [Puncturing rate, Efficiency]	
8	7	6	5	4	3	2	1		
0/1	-	-	-	-	-	-	-	64QAM [6/10 , 5] absent/present	
-	0/1	-	-	-	-	-	-	256QAM [4/6 , 6] absent/present	
-	-	0/1	-	-	-	-	-	256QAM [8/14 , 7] absent/present	
-	-	-	Other				-	-	Reserved

OFDM MCS for DL (Octet 5)

Bit								Modulation class [Puncturing rate, Efficiency]
8	7	6	5	4	3	2	1	
0/1	-	-	-	-	-	-	-	BPSK [1 , 0.5] absent/present
-	0/1	-	-	-	-	-	-	BPSK [3/4 , 0.67] absent/present
-	-	0/1	-	-	-	-	-	QPSK [1 , 1] absent/present
-	-	-	0/1	-	-	-	-	QPSK [4/6 , 1.5] absent/present

-	-	-	-	0/1	-	-	-	16QAM [1 , 2] absent/present
-	-	-	-	-	0/1	-	-	16QAM [4/6 , 3] absent/present
-	-	-	-	-	-	0/1	-	64QAM [3/4 , 4] absent/present
-	-	-	-	-	-	-	0/1	64QAM [6/10 , 5] absent/present

OFDM MCS for DL (Octet 6)

Bit							
8	7	6	5	4	3	2	1
0/1	-	-	-	-	-	-	-
-	0/1	-	-	-	-	-	-
			Other				Reserved
							256QAM [4/6 , 6] absent/present
							256QAM [8/14 , 7] absent/present

EXCH Timing (Octet 7)

Bit		
8	7	6
0	0	0
0	0	1
0	1	0
0	1	1
1	0	0
	Other	Reserved

Self-owned Bandwidth (Octet 7)

Bit				
5	4	3	2	1
0	0	0	0	0
0	0	0	0	1
0	0	0	1	0
		:		:
1	1	1	1	1

1 SCH
2 SCHs
3 SCHs
32 SCHs

Synthesizer (Octet 8)

Bit	
8	7
0	0
0	1
1	0
1	1

No center frequency switching capability (Note 1)
Center frequency switching time class 1 (Note 2)
Center frequency switching time class 2 (Note 3)
Center frequency switching time class 3

(Note 1) BS shall always assign same band to the MS.

(Note 2) When adjacent slots are used within/beyond a frame, BS shall assign same band to the MS.

(Note 3) When adjacent slots next to each other across the TX/RX or RX/TX switching timing are used, BS shall assign same band to the MS.

Error Correction Encoding (Octet 8)

Bit			
6	5	4	
0/1	-	-	Convolutional encoding (Mandatory) absent/present
-	0/1	-	Turbo coding (Optional) absent/present
-	-	0/1	Reserved

RF Number (Octet 8)

Bit		
3	2	
0	0	RF number 1
0	1	RF number 2
1	0	RF number 3
1	1	RF number 4

Full Subcarrier Mode (Octet 8)

Bit	
1	
0/1	Full Subcarrier Mode function absent / present

HARQ Method (Octet 9)

Bit			
8	7	6	
0/1	-	-	CC-HARQ absent/present
-	0/1	-	IR-HARQ (Optional) absent/present
-	-	0/1	Reserved

MIMO (Octet 9)

Bit					
5	4	3	2	1	
0	-	-	-	-	MIMO method 1
	0/1	-	-	-	2 by 2 MIMO (Reserved) absent / present
	-	0/1	-	-	3 by 3 MIMO (Reserved) absent / present
	-	-	0/1	-	4 by 4 MIMO (Reserved) absent / present
	-	-	-	0/1	Reserved
1	-	-	-	-	MIMO method 2
	0/1	-	-	-	2 by 2 MIMO (Reserved) absent / present
	-	0/1	-	-	3 by 3 MIMO (Reserved) absent / present
	-	-	0/1	-	4 by 4 MIMO (Reserved) absent / present
	-	-	-	0/1	Reserved

Window Size (Octet 10)

Bit			
8	7	6	
0	0	0	Reserved
0	0	1	Window size pattern 1

0	1	0	Window size pattern 2
	:	:	
1	1	1	Window size pattern 7

Retransmission Times (Octet 10)

Bit			
5	4	3	
0	0	0	No Retransmission
0	0	1	Once
0	1	0	Twice
	:	:	
1	1	1	7 times

MAC Combine (Octet 10)

Bit	
2	
0	MAC Combine absent
1	MAC Combine present

Figure 7.20 MS Performance

7.3.3.13 MSID

This information element is used to notify MSID.

Octet	Bit	8	7	6	5	4	3	2	1
1	MSID								
	0	0	0	0	0	1	1	0	1
2	MSID Content Length								
3	MSID Indicator			(MSB)		MSID			
	0	0	0						
4	MSID								
5	MSID								
6	MSID								
7	MSID				(LSB)		Reserved		

Octet	Bit	8	7	6	5	4	3	2	1
1	MSID								
	0	0	0	0	1	1	0	1	
2	MSID Content Length								
3	MSID Indicator			(MSB)		MSID			
	0	0	1						
4	MSID								
5	MSID								
6	MSID (LSB)			Reserved					

Octet	Bit	8	7	6	5	4	3	2	1
1	MSID								
	0	0	0	0	1	1	0	1	
2	MSID Content Length								
3	MSID Indicator			(MSB)		MSID			
	0	1	0						
4	MSID								
5	MSID								
6	MSID								
7	MSID								
8	MSID								
9	MSID (LSB)			Reserved					

MSID Indicator (Octet 3)

Bit	8	7	6	
	0	0	0	34 bits MSID
	0	0	1	24 bits MSID
	0	1	0	50 bits MSID
Other				Reserved

Figure 7.21 MSID

7.3.3.14 Protocol Version

This information element is used to notify protocol version.

Octet	Bit							
	8	7	6	5	4	3	2	1
1	Protocol Version							
	0	0	0	0	1	1	1	0
2	Protocol Version Content Length							
3	Protocol Version Number							

Protocol Version Number (Octet 3)

Bit							
8	7	6	5	4	3	2	1
-	-	-	-	-	-	-	0/1
Other						Reserved	

Figure 7.22 Protocol Version

7.3.3.15 PRU Information

This information element is used to specify additional PRU.

Octet	Bit							
	8	7	6	5	4	3	2	1
1	PRU Information							
	0	0	0	0	1	1	1	1
2	PRU Information Content Length							
3	Map Timing (Note)	Map Origin (Note)					Reserved	
4	PRU Number							Re- served

(Note) Map timing and map origin are considered to be undefined, when assign channel type in “link setup request” message or “extension function response” message is CSCH.

Map Timing (Octet 3)

Bit	
8	
0	Timing 1
1	Timing 2

Map Origin (Octet 3)

Bit	7	6	5	4	3	
0	0	0	0	0	0	SCH 1
0	0	0	0	0	1	SCH 2
0	0	0	1	0	0	SCH 3
			:			:
1	0	0	1	1	1	SCH 20
		Other				Reserved

PRU Number (Octet 4)

					Bit		
8	7	6	5	4	3	2	
0	0	0	0	0	0	0	PRU 1
0	0	0	0	0	0	1-	PRU 2
0	0	0	0	0	1	0-	PRU 3
			:			:	
1	0	0	1	1	1	1-	PRU 80
		Other					Reserved

Figure 7.23 PRU Information

7.3.3.16 QCS Information

This information element is used to notify QCS-ID.

	Bit	8	7	6	5	4	3	2	1
Octet									
1		QCS Information							
		0	0	0	1	0	0	0	0
2		QCS Information Content Length							
3		Connection Status							
4		Connection Status							

Connection Status (Octet 3)

Bit	8	7	6	5	4	3	2	1	
0/1	-	-	-	-	-	-	-	-	QCS-ID 1 connection absent/present
-	0/1	-	-	-	-	-	-	-	QCS-ID 2 connection absent/present
-	-	0/1	-	-	-	-	-	-	QCS-ID 3 connection absent/present
			:					:	
-	-	-	-	-	-	-	-	0/1	QCS-ID 8 connection absent/present

(Note) Octet 3, Bit 8 (QCS-ID=1(for control)) is always set to 1 on sender. (Don't care for receiver)

Connection Status (Octet 4)

Bit	8	7	6	5	4	3	2	1	
0/1	-	-	-	-	-	-	-	-	QCS-ID 9 connection absent/present
-	0/1	-	-	-	-	-	-	-	QCS-ID 10 connection absent/present
-	-	0/1	-	-	-	-	-	-	QCS-ID 11 connection absent/present
			:					:	
-	-	-	-	-	-	-	-	0/1	QCS-ID 16 connection absent/present

Figure 7.24 QCS Information

7.3.3.17 QoS

This information element is used to notify QoS.

Octet	8	7	6	5	4	3	2	1
1	QoS							
	0	0	0	1	0	0	0	1
2	QoS Content Length							
3	Reserved				QoS Number			

QoS Number (Octet 3)

Bit	4	3	2	1	
0	0	0	0	0	LAC
0	0	0	0	1	PLC
0	0	1	0		nl-VRC
0	0	1	1		al-VRC

0	1	0	0	Ld-BE
0	1	1	0	Voice
				Other Reserved

Figure 7.25 QoS

7.3.3.18 QCS Status

This information element is used to notify QCS Status.

Octet	Bit							
	8	7	6	5	4	3	2	1
1	QCS Status							
	0	0	0	1	0	0	1	0
2	QCS Status Content Length							
3	QCS-ID				Connection-ID			
4	Reserved				QoS Number			
5	QCS-ID				Connection-ID			
6	Reserved				QoS Number			
:								
33	QCS-ID				Connection-ID			
34	Reserved				QoS Number			

(Note) Omit the setting of QCS-ID=1 on sender. And receiver ignores setting of QCS-ID=1.

(Note) Omit the setting of unused QCS(s).

QCS-ID (Octet 3~33)

Bit				
4	3	2	1	
0	0	0	0	QCS-ID 1
0	0	0	1	QCS-ID 2
0	0	1	0	QCS-ID 3
		:	:	
1	1	1	1	QCS-ID 16

(Note) Omit the setting of QCS-ID=1 on sender. And receiver ignores setting of QCS-ID=1.

Connection-ID (Octet 3~33)

Bit				
4	3	2	1	
0	0	0	0	Connection-ID 1
0	0	0	1	Connection-ID 2
0	0	1	0	Connection-ID 3
		:	:	
1	1	1	1	Connection-ID 16

QoS Number (Octet 4~34)

Bit				
8	7	6	5	
0	0	0	0	QoS Number 1
0	0	0	1	QoS Number 2
0	0	1	0	QoS Number 3
	:		:	
1	1	1	1	QoS Number 16

Figure 7.26 QCS Status

7.3.3.19 Scheduling Information

This information element is used to notify scheduling information.

Octet	Bit							
	8	7	6	5	4	3	2	1
1	Scheduling Information							
	0	0	0	1	0	0	1	1
2	Scheduling Information Content Length							
3	Scheduling Term				Reserved			
4	Active Frame							
5	Active Frame							

Scheduling Term (Octet 3)

Bit				
8	7	6	5	
0	0	0	0	1 TDMA frame
0	0	0	1	2 TDMA frames
0	0	1	0	3 TDMA frames
	:		:	
1	1	1	1	16 TDMA frames

Active Frame (Octet 4)

Bit								
8	7	6	5	4	3	2	1	
0/1	-	-	-	-	-	-	-	Frame 1 not active/active
-	0/1	-	-	-	-	-	-	Frame 2 not active/active

-	-	0/1	-	-	-	-	-	-	Frame 3 not active/active
-	-	-	0/1	-	-	-	-	-	Frame 4 not active/active
-	-	-	-	0/1	-	-	-	-	Frame 5 not active/active
-	-	-	-	-	0/1	-	-	-	Frame 6 not active/active
-	-	-	-	-	-	0/1	-	-	Frame 7 not active/active
-	-	-	-	-	-	-	0/1	-	Frame 8 not active/active

Active Frame (Octet 5)

Bit	8	7	6	5	4	3	2	1	
0/1	-	-	-	-	-	-	-	-	Frame 9 not active/active
-	0/1	-	-	-	-	-	-	-	Frame 10 not active/active
-	-	0/1	-	-	-	-	-	-	Frame 11 not active/active
-	-	-	0/1	-	-	-	-	-	Frame 12 not active/active
-	-	-	-	0/1	-	-	-	-	Frame 13 not active/active
-	-	-	-	-	0/1	-	-	-	Frame 14 not active/active
-	-	-	-	-	-	0/1	-	-	Frame 15 not active/active
-	-	-	-	-	-	-	0/1	-	Frame 16 not active/active

Figure 7.27 Scheduling Information

7.3.3.20 Source BS-info

This information element is used to notify source BS-info before performing handover.

Octet	8	7	6	5	4	3	2	1
1	Source BS-info							
	0	0	0	1	0	1	0	0
2	Source BS-info Content Length							
3	(MSB)			BS-info				
4	BS-info							
5	BS-info							
6	BS-info							
7	BS-info							(LSB)

Figure 7.28 Source BS-info

7.3.3.21 Target BS-info

This information element is used to notify BS-info of handover schedule.

Octet	Bit								
	8	7	6	5	4	3	2	1	
1	Target BS-info								
	0	0	0	1	0	1	0	1	
2	Target BS-info Content Length								
3	(MSB)				BS-info				
4					BS-info				
5					BS-info				
6					BS-info				
7					BS-info				(LSB)

(Note) This information element is used to notify BS-info before performing handover.

Figure 7.29 Target BS-info

7.3.3.22 MAP Origin

This information element is used to notify MAP origin.

Octet	Bit							
	8	7	6	5	4	3	2	1
1	MAP Origin							
	0	0	0	1	0	1	1	0
2	MAP Origin Content Length							
3	Map Timing		Map Origin				Reserved	

Map Timing (Octet 3)

Bit	
8	
0	Timing 1
1	Timing 2

Map Origin (Octet 3)

Bit	7	6	5	4	3	
	0	0	0	0	0	SCH 1
	0	0	0	0	1	SCH 2
	0	0	0	1	0	SCH 3
			⋮		⋮	
	1	0	0	1	1	SCH 20
			Other			Reserved

Figure 7.30 MAP Origin

7.3.3.23 MSID (SC)

This information element is used to notify MSID in Link Setup Request (SC) message. This information element has particular structure in order to reduce the message size.

Octet	Bit	8	7	6	5	4	3	2	1
1	Protocol version Number								
2	MSID Indicator			(MSB) MSID					
	0	0	0						
3	MSID								
4	MSID								
5	MSID								
6	MSID				(LSB)		Reserved		Start Indication

Octet	Bit	8	7	6	5	4	3	2	1
1	Protocol version Number								
2	MSID Indicator			(MSB)		MSID			
	0	0	1						
3	MSID								
4	MSID								
5	MSID (LSB)			Reserved				Start Indica- tion	

Octet	Bit	8	7	6	5	4	3	2	1
1	Protocol version Number								
2	MSID Indicator			(MSB)		MSID			
	0	1	0						
3	MSID								
4	MSID								
5	MSID								
6	MSID								
7	MSID								
8	MSID (LSB)			Reserved				Start Indica- tion	

Protocol Version Number (Octet 1)

Bit	8	7	6	5	4	3	2	1	
	-	-	-	-	-	-	-	0/1	Version 1 absent / present
	Other								Reserved

MSID Indicator (Octet 2)

Bit	8	7	6	
	0	0	0	34 bits MSID
	0	0	1	24 bits MSID
	0	1	0	50 bits MSID

Other Reserved

Start Indication (Octet 6/5/8)

Bit	
4	
0	Extension function sequence absent
1	Extension function sequence present

	Bit	8	7	6	5	4	3	2	1
Octet									
1	Protocol Version Number								
		0	0	0	1	0	1	1	0
2	MAP Origin Content Length								
3	Map Timing	Map Origin						Reserved	

7.3.3.24 Power Report

	Bit	8	7	6	5	4	3	2	1
Octet									
1	Power Report								
		0	0	0	1	0	1	1	1
2	Power Report Content Length								
3	Transmission Power Margin								

Transmission Power Margin (Octet 3)

Bit	8	7	6	5	4	3	2	1	
	0	0	0	0	0	0	0	0	0 dB
	0	0	0	0	0	0	0	1	1 dB
				:					:
	0	1	0	1	0	0	0	0	80 dB
				Other					Reserved

(Note) 1dB unit

7.3.3.25 Report Indication

Octet	Bit							
	8	7	6	5	4	3	2	1
1	Report Indication							
	0	0	0	1	1	0	0	0
2	Report Indication Content Length							
3	Report Indication Content		Reserved					

Report Indication Content (Octet 3)

Bit		
8	7	
0/1	-	CQI Request absent/present
-	0/1	Power Report Request absent/present

7.3.3.26 Encryption Key Information

This information element is used to notify encryption key information.

Octet	Bit							
	8	7	6	5	4	3	2	1
1	Encryption Key Information							
	0	0	0	1	1	0	0	1
2	Encryption Key Information Content Length							
6	Key Lifetime							

Key Lifetime (Octet 6)

Key Lifetime notifies MS of encryption key lifetime.

7.3.4 Information Element Rules

7.3.4.1 Error process

This section describes about error processing of messages and information elements in Access Establishment Phase Control.

7.3.4.1.1 Protocol Identifier

When the message which has not protocol identifier "Access Establishment Phase Control" is received, receiver shall ignore the message.

7.3.4.1.2 Incomplete message

When the message of which actual length is shorter than expected is received, receiver shall ignore the message.

7.3.4.1.3 Unexpected message type or message sequence error

When unexpected message is received, receiver shall ignore the message and no state transition occurs.

7.3.4.1.4 Mandatory information element error

7.3.4.1.4.1 Missing mandatory information element

When the message which does not include mandatory information element(s) is received, receiver shall ignore the message and no state transition occurs.

7.3.4.1.4.2 Invalid mandatory information element

When the message which includes invalid mandatory information element(s) is received, the message shall be ignored at reception side, and no state transition carried out.

When the message which has longer data length than expected one is received, reception side shall ignore extra content(s).

When the message which has shorter data length than expected one is received, the message is identified as a message which contains contents error.

7.3.4.1.4.3 Unexpected mandatory information element

When the message which has unexpected mandatory information element(s) is received, receiver shall ignore the unexpected information element(s).

Other information elements shall be adopted if they are expected ones.

7.3.4.1.4.4 Unrecognized mandatory information element

When the message which has unrecognized mandatory information element(s) is received, receiver shall ignore the unrecognized information element(s).

Other information elements shall be adopted if they are recognized one.

7.3.4.1.5 Optional information element error

When a message which contains one or more invalid optional information elements is received, receiver acts only for information elements which contains valid contents.

When a information element which has longer content length than expected one is received, the information element is valid until the content length which is expected.

When a information element which has shorter content length than expected one is received, the information is recognized as error information element.

7.3.4.2 Information elements order

This section describes about the order of each information element for message transmission and reception, as follows.

<In case of message transmission>

Information elements are set from smaller information element code. Single octet information element is judged by filling the lower four bits with zero.

< In case of message reception >

Receiver does not care information element order.

(Note) Even if reception information elements are not set from smaller information element code, receiver always recognize as correct information elements.

7.3.4.3 Duplicated information elements

This section describes about the operation when duplicated information elements are set in the message, as follows.

<In case of message reception>

Receiver shall process only acceptable duplicated information elements from the top, and ignore subsequent unacceptable duplicated information elements.

(Note) The number of duplication of information elements is only one in the current standard.

Chapter 8 Sequence

8.1 Overview

In this section, the standard control sequences between BS and MS are described. The names of messages transmitted and received between MS and BS are defined in Chapter 7.

8.2 Sequence

8.2.1 Outgoing Call

Figure 8.1 shows sequence of an outgoing call.
The control order is as follows:

[1] LCH Assignment Request and Response

MS requests LCH assignment by transmitting "LCH assignment request" message on TCCH to BS, and BS assigns a LCH by sending/transmitting "LCH assignment response" message on SCCH.

[2] Link Setup Request and Response

MS performs carrier sensing for the assigned LCH channel. MS notifies the start of communication by sending/transmitting "link setup request" message when it judges that the assigned channel is not interfered and available. MS also notifies BS the communication ability, MSID etc in this message. BS notifies MS the function to use in this communication by sending/transmitting "link setup response" message.

[3] Extension Function Request and Response

When the extra function of this LCH is necessary to be negotiated or changed, the content of the function change is notified by "extension function request and response" message.

This message can be omitted if it is not necessary. It is notified with "extension function request" message when this message is necessary.

[4] Connection Request

MS notifies the type of QoS connection to BS. The connection type in this case is outgoing call.

[5] Authentication

The authentication information is transmitted between BS and MS when it is necessary in this sequence. The authentication method is not specified in this document.

[6] Encryption Key Indication

BS transfers the encryption key to MS.

[7] Connection Response

BS notifies MS Connection-ID, QCS information, etc.

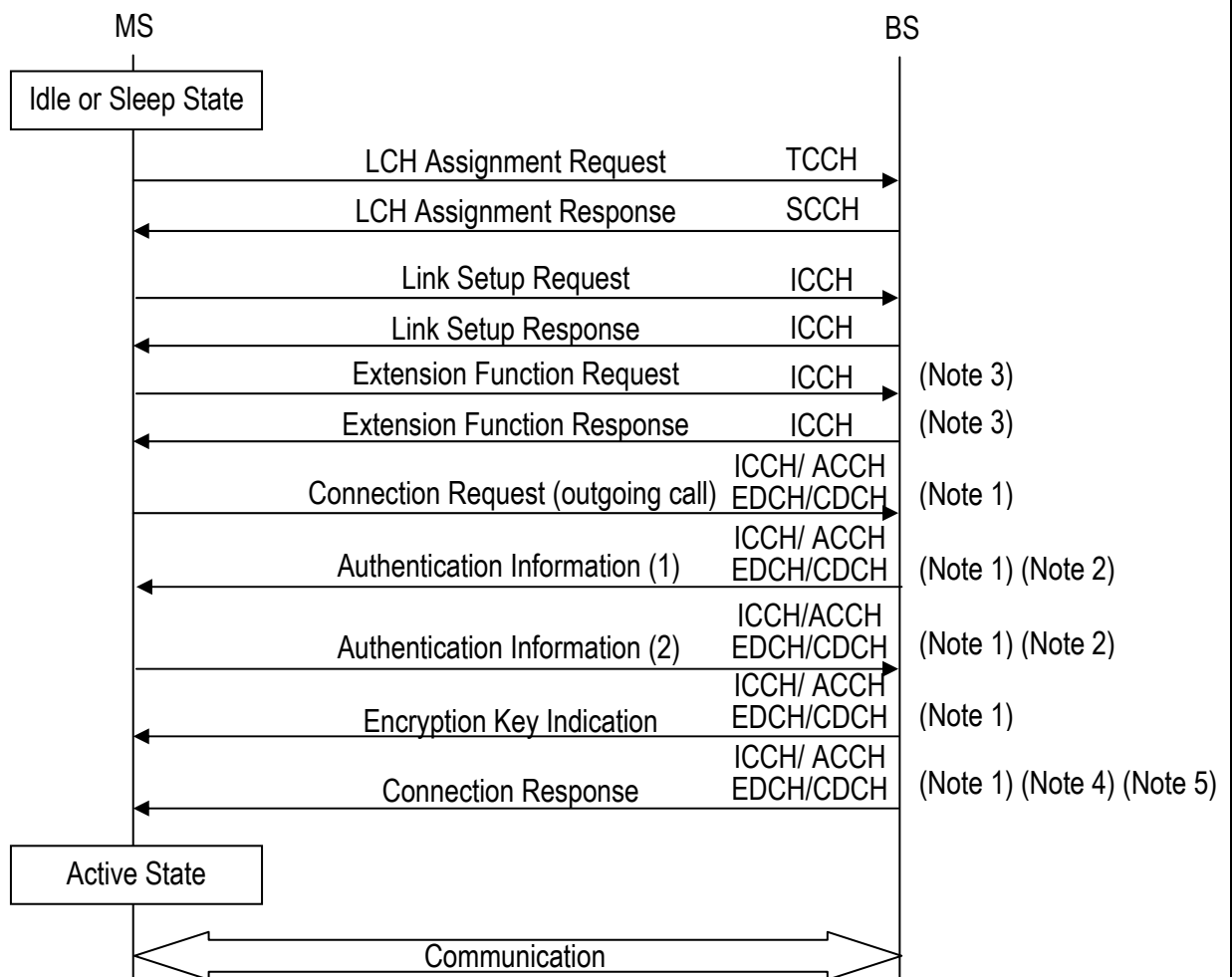

Figure 8.1 Outgoing Call Sequence

Note 1 When these control messages are transmitted with EDCH/CDCH/ICCH, the CD bit of the MAC header is set as 00 or 01.

Note 2 This is one example for the authentication sequence.

Note 3 This message is optional.

Note 4 When connection type is outgoing call with location registration, the sequence becomes a similar sequence with that of an outgoing call. At this time, the result of location registration is notified with “connection response” message.

Note 5 In case of having received Connection Response message including MSID information element, MS shall use temporary ID value which is set in MSID information element afterwards.

8.2.2 Incoming Call

Figure 8.2 shows incoming call sequence.
The control order is as follows:

[1] Paging and LCH Assignment Request and Response

Paging message is sent on PCH from BS. MS requests LCH assignment to BS by sending "LCH assignment request" message on TCCH, and BS assigns a LCH by sending "LCH assignment response" message on SCCH.

[2] Link Setup Request and Response

MS performs carrier sensing for the assigned LCH channel. MS notifies the start of communication by sending "Link Setup Request" message when it judges that this assigned channel is not interfered and available. In this message, MS also notifies BS of the communication ability, MSID etc. BS notifies MS the function to use in this communication by sending "link setup response" message.

[3] Extension Function Request and Response

When the extra function of this LCH is necessary to be negotiated or changed, the content of the function change is notified with "extension function request and response" message.

This message can be omitted if it is not necessary. It is notified with "extension function request" message when this message is necessary.

[4] Connection Request

MS notifies the type of QoS connection to BS. The connection type in this case is an incoming call.

[5] Authentication

The authentication information is transmitted between BS and MS when it is necessary in this sequence. The authentication method is not specified in this document.

[6] Encryption Key Indication

BS transfers the encryption key to MS.

[7] Connection Response

BS notifies MS Connection-ID, QCS information, etc.

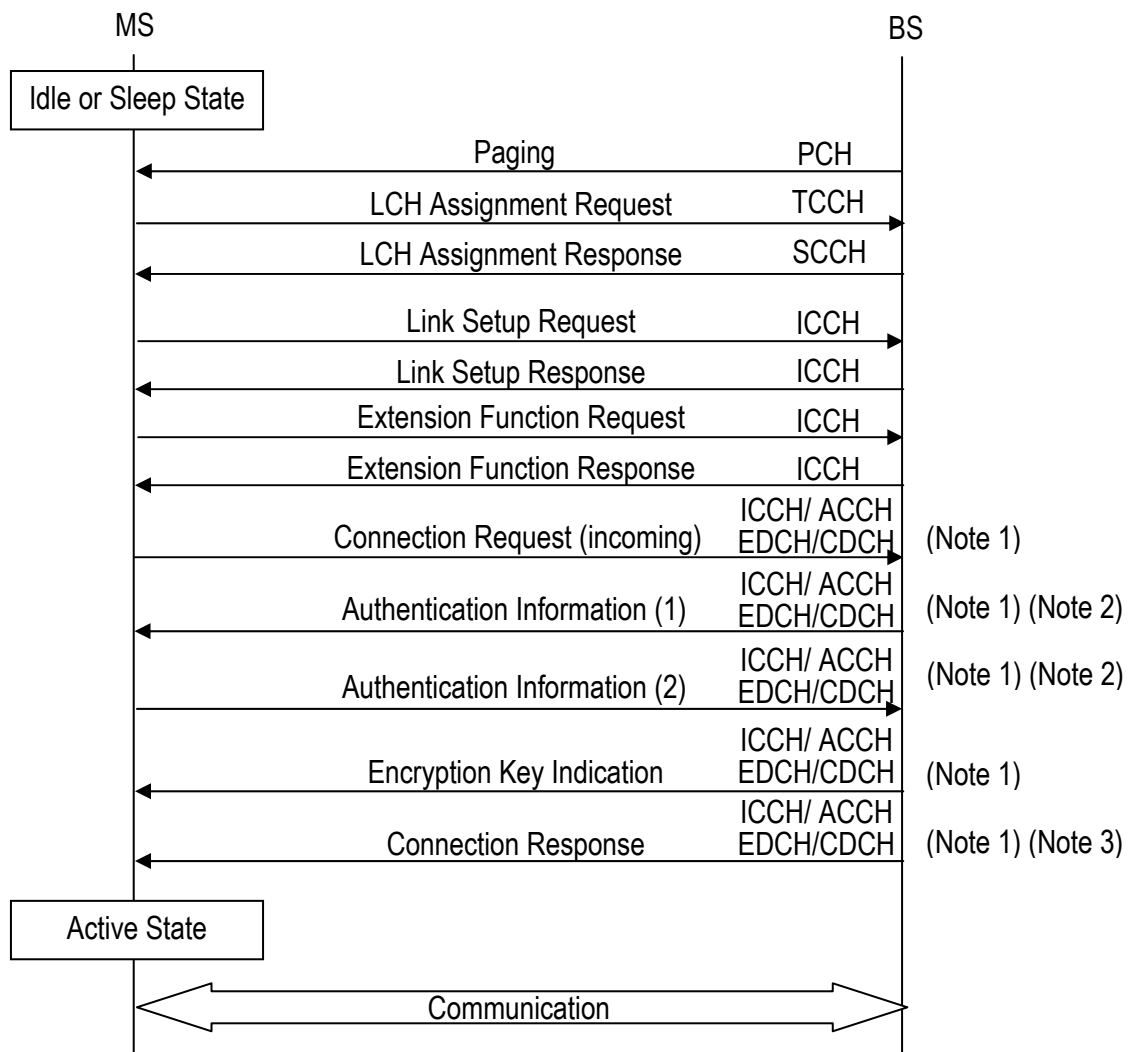

Figure 8.2 Incoming Call Sequence

Note 1 When control data is transmitted with EDCH/CDCH/ICCH, the CD bit of the MAC header is set as 00 or 01.

Note 2 This is one example for the authentication sequence.

Note 3 In case of having received Connection Response message including MSID information element, MS shall use temporary ID value which is set in MSID information element afterwards.

8.2.3 Release

8.2.3.1 Connection Release

8.2.3.1.1 Connection Release from MS

Figure 8.3 shows the sequence of connection release from MS. “connection release” message is used when connection-ID is released.

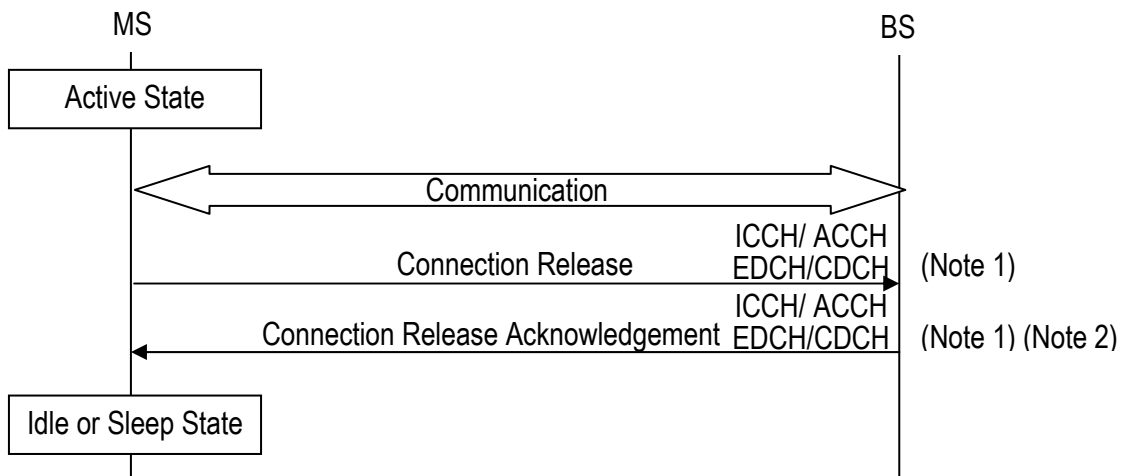

Figure 8.3 Connection Release from MS Sequence

Note 1 When control data is transmitted with EDCH/CDCH/ICCH, the CD bit of the MAC header is set as 00 or 01.

Note 2 In case of having received Connection Release Acknowledgement message including MSID information element, MS shall use temporary ID value which is set in MSID information element afterwards.

8.2.3.1.2 Connection Release from BS

Figure 8.4 shows the sequence of connection release from BS. “connection release” message is used when connection-ID is released.

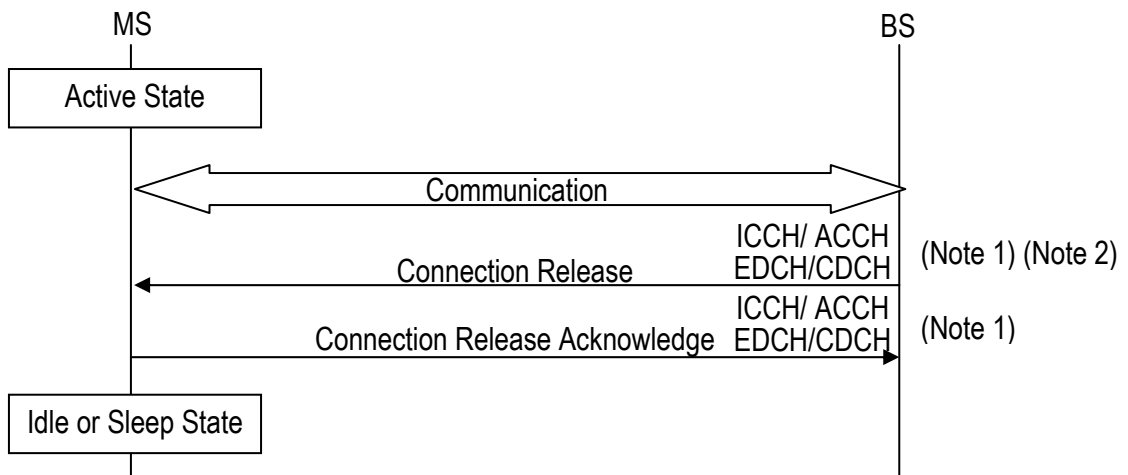

Figure 8.4 Connection release from BS Sequence

Note 1 When control data is transmitted with EDCH/CDCH/ICCH, the CD bit of the MAC header is set as 00 or 01.

Note 2 In case of having received Connection Release message including MSID information element, MS shall use temporary ID value which is set in MSID information element afterwards.

8.2.3.2 QCS Release

8.2.3.2.1 QCS Release Triggered by MS

Figure 8.5 shows the sequence of QCS release triggered by MS. "QCS release" message is used when QCS information is released.

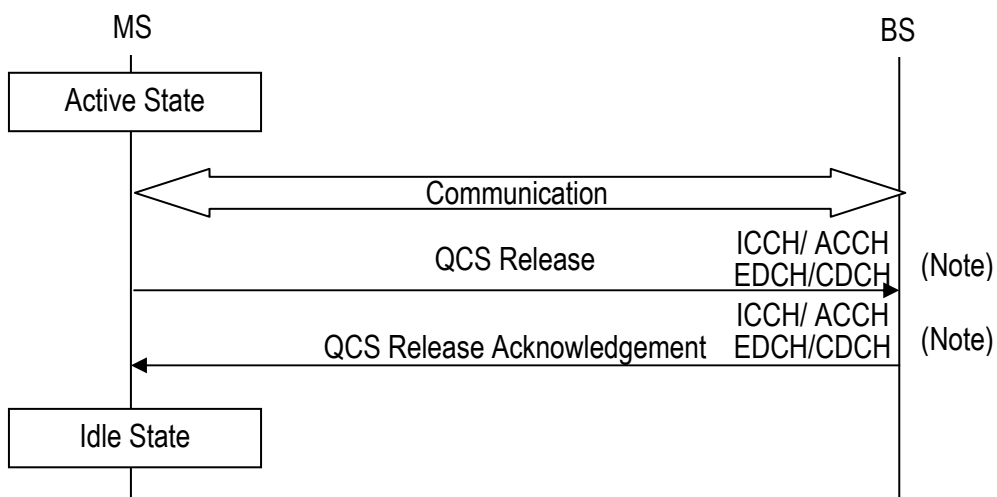

Figure 8.5 QCS Release Triggered by MS Sequence

Note When control data is transmitted with EDCH/CDCH/ICCH, the CD bit of the MAC header is set as 00 or 01.

8.2.3.2.2 QCS Release Triggered by BS

Figure 8.6 shows the sequence of QCS release triggered by BS. When QCS is released, "QCS release" message is used.

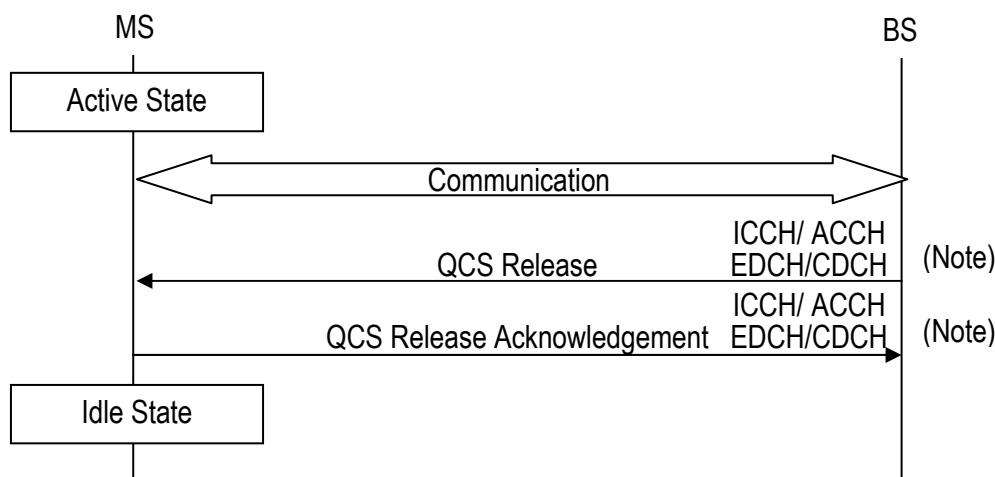

Figure 8.6 QCS Release Triggered by BS Sequence

Note When control data is transmitted with EDCH/CDCH/ICCH, the CD bit of the MAC header is set as 00 or 01.

8.2.4 Location Registration

Figure 8.7 shows the location registration sequence. Location registration is activated when MS moves to others paging area, or is powered at a different paging area. Home Location Register (HLR) control in network executes the location registration control. MS sends the location registration data on ICCH before the call connection. The control order is as follows:

[1] LCH Assignment Request and Response

MS requests LCH assignment to BS by sending "LCH assignment request" message on TCCH, and BS assigns a LCH by sending "LCH assignment response" message on SCCH.

[2] Link Setup Request and Response

MS performs carrier sensing for the assigned LCH channel. MS notifies the start of communication by sending "link setup request" message when it judges that this assigned channel is not interfered and available. In this message, MS also notifies BS of the communication ability, MSID etc. BS notifies MS the function to use in this communication by sending "link setup response" message.

[3] Extension Function Request and Response

When the extra function of this LCH is necessary to be negotiated or changed, the content of the function change is notified with "extension function request and response" message.

This message can be omitted if it is not necessary. It is notified with “extension function request” message when this message is necessary.

[4] Connection Request

MS notifies the kind of QoS connection to BS. The connection type in this case is “location registration”.

[5] Authentication

The authentication information is transmitted between BS and MS when it is necessary in this sequence. The authentication method is not specified in this document.

[6] Encryption Key Indication

BS transfers the encryption key to MS.

[7] Connection Response

Connection-ID is omitted and the result of location registration is notified in a “connection response” message. Moreover, cause value in cause information element is set to no connection-ID, and connection is disconnected.

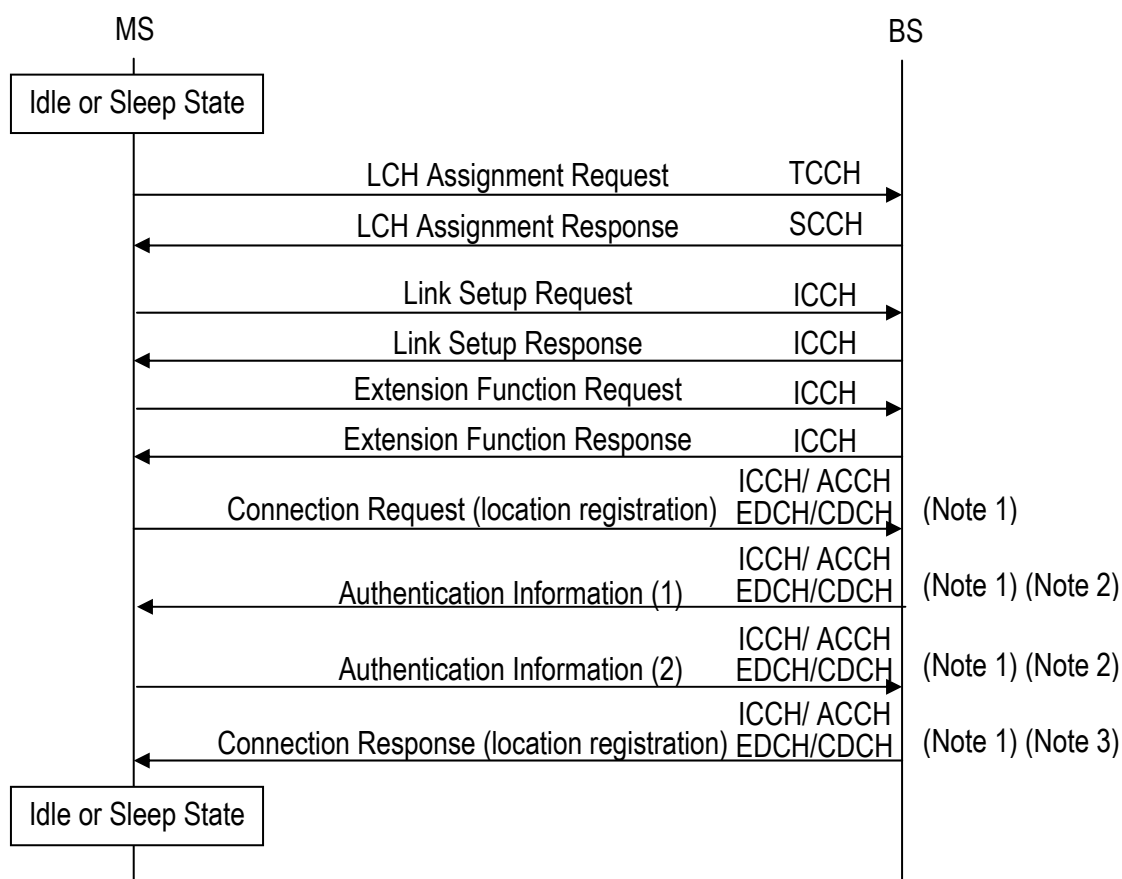

Figure 8.7 Location Registration Sequence

Note 1 When control data is transmitted with EDCH/CDCH/ICCH, the CD bit of the MAC header is set as 00 or 01.

Note 2 This is one example for the authentication sequence.

Note 3 Connection-ID is omitted when the result of location registration is notified. In addition, cause value in cause information element is set to no connection-ID and connection is

disconnected.

8.2.5 ANCH/CSCH Switching

8.2.5.1 ANCH/CSCH Switching Triggered by MS

Figure 8.8 shows the sequence of ANCH/CSCH switching sequence triggered by MS. When BS receives “ANCH/CSCH switching request” message, it transmits “ANCH/CSCH switching indication” message to MS and MS performs channel switching.

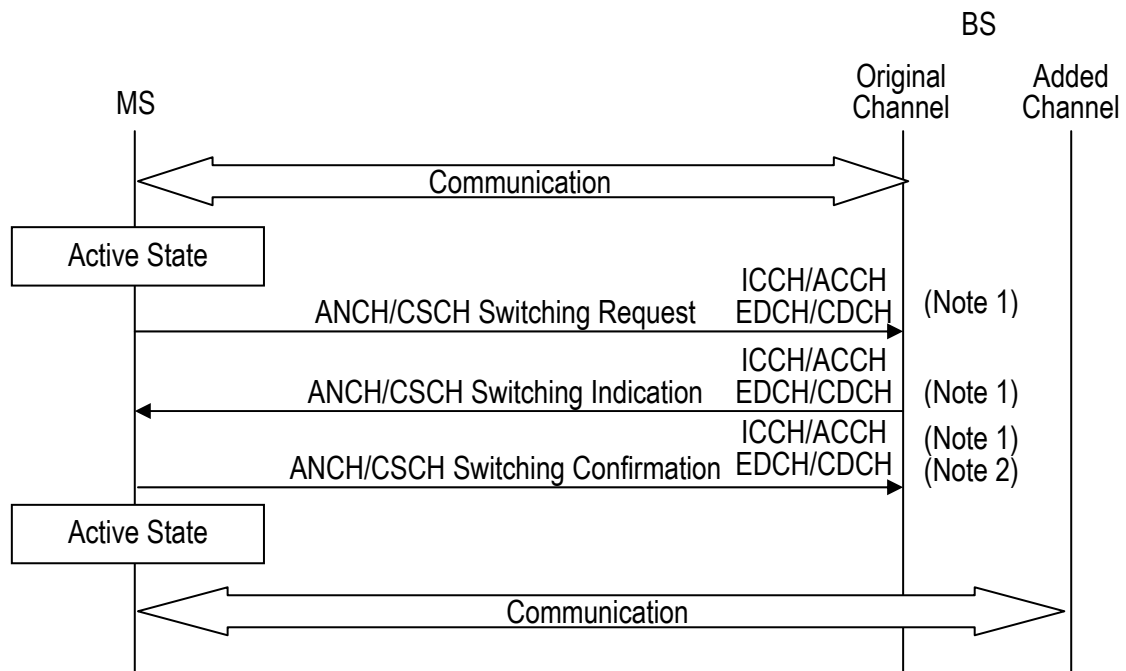

Figure 8.8 ANCH/CSCH Switching Triggered by MS Sequence

Note 1 This message is transmitted on by ICCH, while communicating in FM-Mode. This message is transmitted on ACCH or CDCH while communicating in QS-Mode.

Note 2 This message is mandatory when communicating in ANCH/CSCH scheduling mode (intermittent transmission).

8.2.5.2 ANCH/CSCH Switching Triggered by BS

Figure 8.9 shows the sequence of ANCH/CSCH switching sequence triggered by BS. BS transmits “ANCH/CSCH switching indication” message to MS When it detects the communication quality degradation and MS performs channel switching.

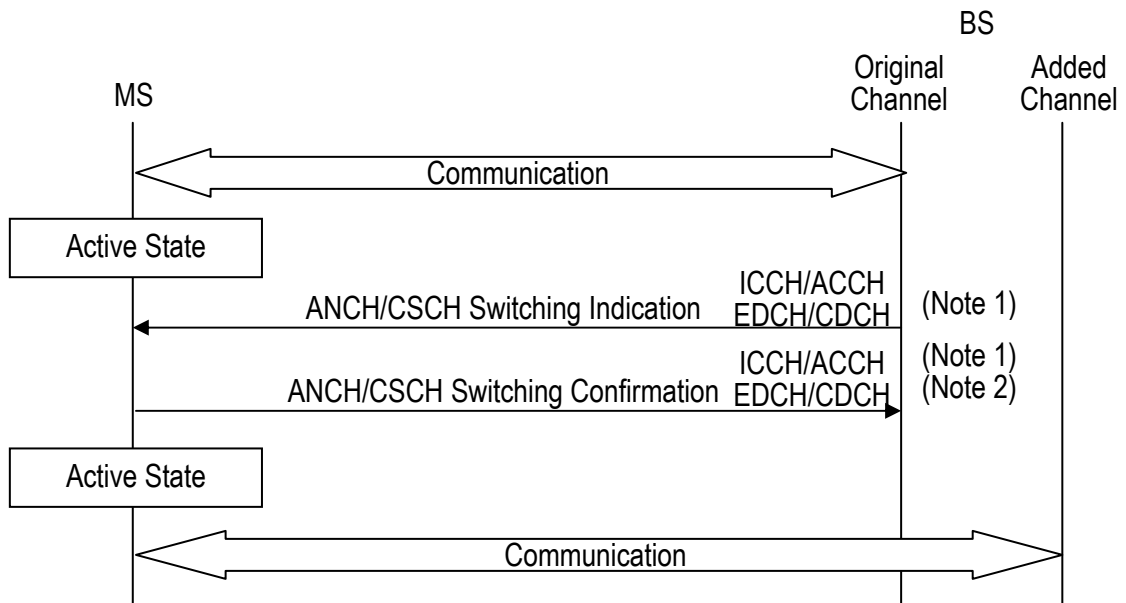

Figure 8.9 ANCH/CSCH Switching Triggered by BS Sequence

Note 1 This message is transmitted on ICCH while communicating in FM-Mode. This message is transmitted on ACCH or CDCH while communicating in QS-Mode.

Note 2 This message is mandatory when communicating in ANCH/CSCH scheduling mode (intermittent transmission).

8.2.5.3 ANCH/CSCH Switching Rejection

Figure 8.10 shows the sequence of ANCH/CSCH switching rejection sequence.

BS transmits "ANCH/CSCH switching rejection" message to MS when BS receive "ANCH/CSCH switching request" message from MS.

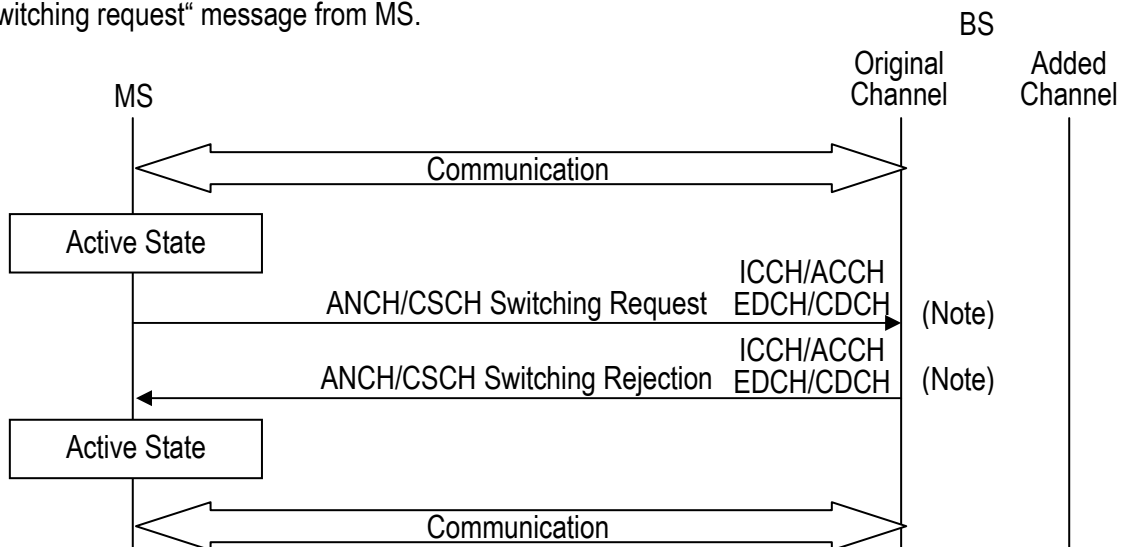

Figure 8.10 ANCH/CSCH Switching Rejection Sequence

Note This message is transmitted on ICCH while communicating in FM-Mode. This message is transmitted on with ACCH or CDCH while communicating in QS-Mode.

8.2.5.4 ANCH/CSCH Switching Re-request

Figure 8.11 shows the sequence of “ANCH/CSCH switching re-request” message triggered by BS.

BS sends “ANCH/CSCH switching indication” message to MS when it detects the communication quality degradation transmits. MS then transmits “ANCH/CSCH switching re-request” message instead of performing channel switching.

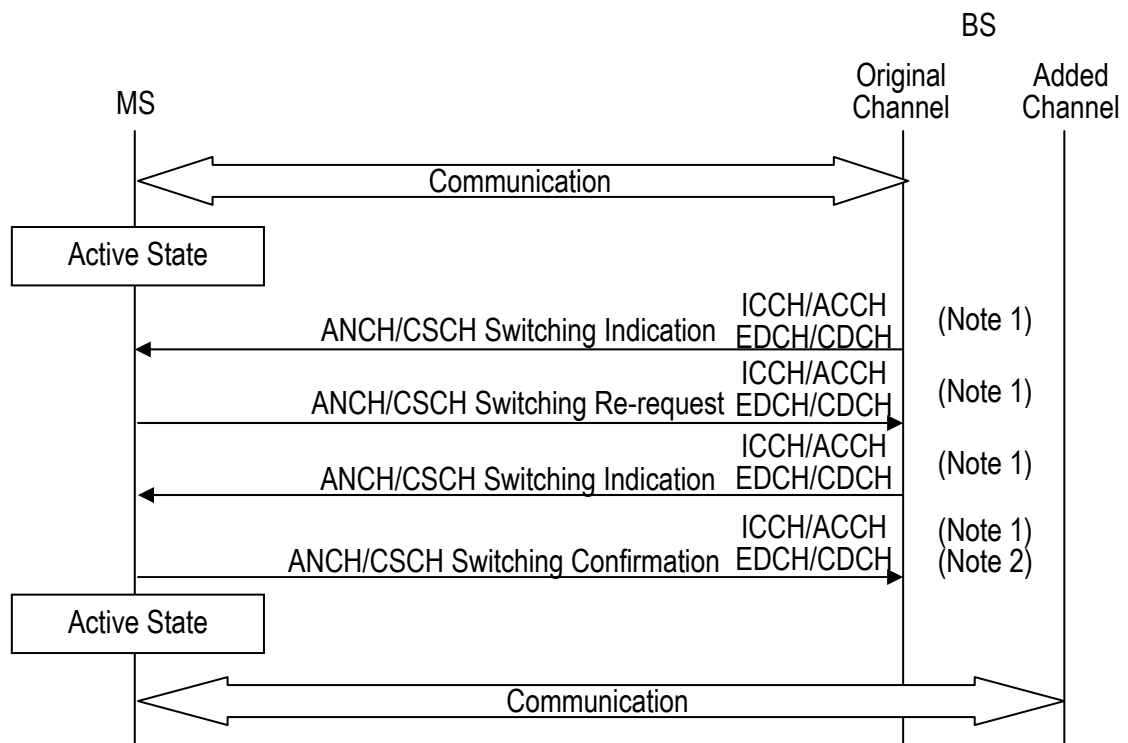

Figure 8.11 ANCH Switching Re-request Sequence

Note 1 This message is transmitted on ICCH while communicating in FM-Mode. This message is transmitted on ACCH or CDCH while communicating in QS-Mode.

Note 2 This message is mandatory when communicating in ANCH/CSCH scheduling mode (intermittent transmission).

8.2.6 Handover

8.2.6.1 Normal Handover Triggered by BS

Figure 8.12 shows the normal handover sequence triggered by BS.
The control order is as follows:

[1] ANCH/CSCH Switching Request and Response

BS sends “ANCH/CSCH switching indication” message and indicates handover on detecting the communication quality degradation. MS shuts down the power and conduct transmission on receiving “ANCH/CSCH switching indication” message.

[2] LCH Assignment Request and Response

MS requests LCH assignment to BS by sending “LCH assignment request” message on TCCH, and BS assigns a LCH by sending “LCH assignment response” message on SCCH.

[3] Link Setup Request and Response

MS performs carrier sensing for the assigned LCH channel. MS notifies start of the communication by sending “link setup request” message when it judges that this assigned channel is not interfered and available. In this message, MS also notifies BS of the communication ability, MSID etc. BS notifies MS of the function to use in this communication by sending “link setup response” message.

[4] Extension Function Request and Response

When the extra function of this LCH is necessary to be negotiated or changed, the content of the function change is notified with “extension function request and response” message. This message can be omitted if it is not necessary. It is notified with “extension function request” message when necessary.

[5] Connection Request

MS notifies the type of QoS connection to BS. The connection type in this case is handover.

[6] Authentication

The authentication information is transmitted between BS and MS when it is necessary in this sequence. The authentication method is not specified in this document.

[7] Encryption Key Indication

BS transfers the encryption key to MS.

[8] Connection Response

BS notifies MS of Connection-ID, QCS information, etc.

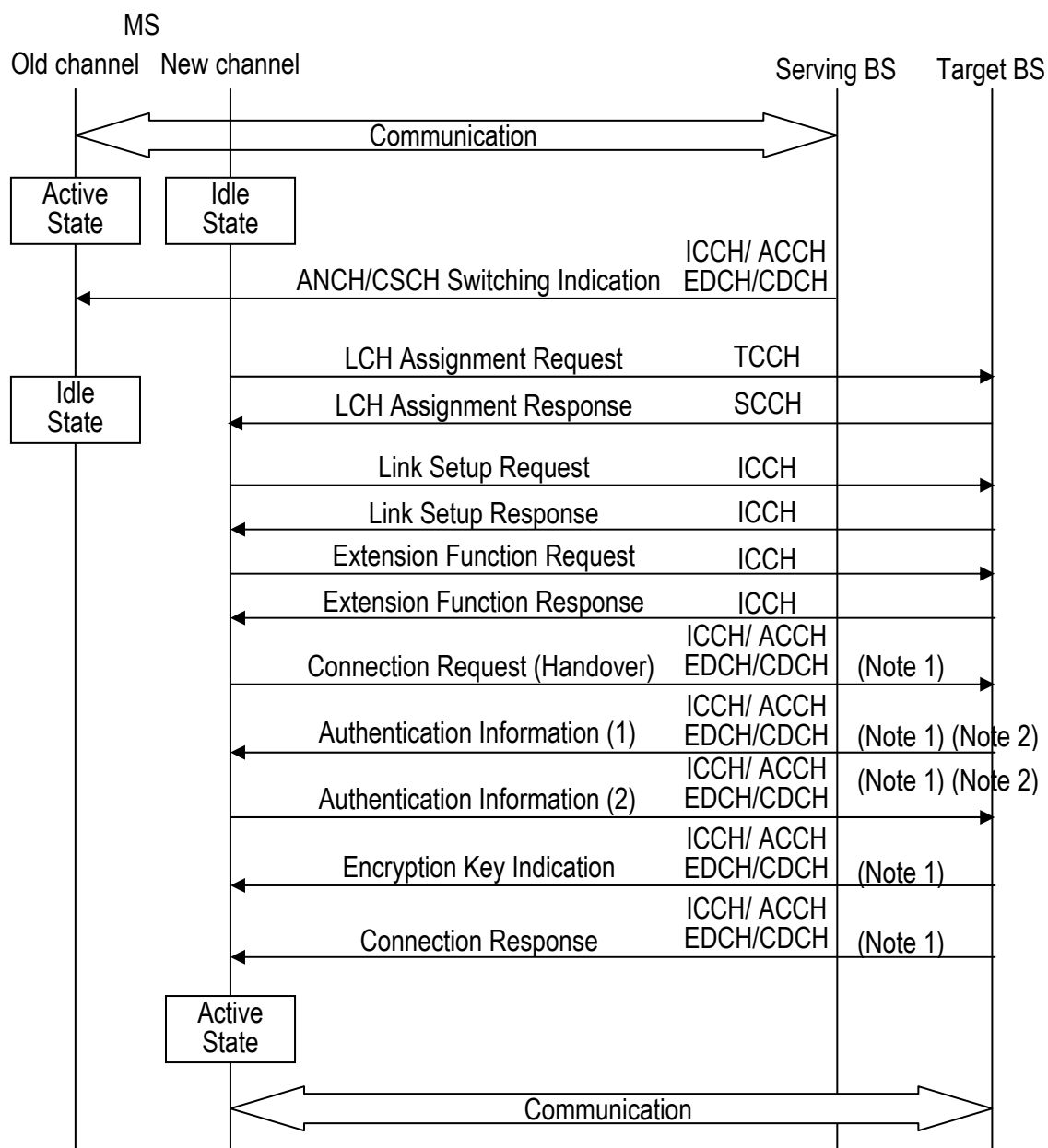

Figure 8.12 Normal Handover Triggered by BS Sequence

Note 1 When control data is transmitted with EDCH/CDCH/ICCH, the CD bit of the MAC header is set as 00 or 01.

Note 2 This is one example for the authentication sequence.

8.2.6.2 Normal Handover Triggered by MS

Figure 8.13 shows the normal handover sequence triggered by MS.
The control order is as follows:

[1] ANCH/CSCH Switching Request and Response

MS sends “ANCH/CSCH switching request” message when it detects the communication quality degradation, and BS indicates handover by sending “ANCH/CSCH switching indication” message. MS shuts down the power and conduct transmission on receiving “ANCH/CSCH switching indication” message.

[2] LCH Assignment Request and Response

MS requests LCH assignment to BS by sending “LCH assignment request” message on TCCH, and BS assigns a LCH by sending “LCH assignment response” message on SCCH.

[3] Link Setup Request and Response

MS performs carrier sensing for the assigned LCH channel. When MS notifies the start of communication by sending “link setup request” message when it judges that this assigned channel is not interfered and available. In this message, MS also notifies BS of the communication ability, MSID etc. BS notifies MS of the function to use in this communication by sending “link setup response” message.

[4] Extension Function Request and Response

When the extra function of this LCH is necessary to be negotiated or changed, the content of the function change is notified with “extension function request and response” message. This message can be omitted if it is not necessary. It is notified with “extension function request” message when necessary.

[5] Connection Request

MS notifies the type of QoS connection to BS. The connection type in this case is handover.

[6] Authentication

The authentication information is transmitted between BS and MS when it is necessary in this sequence. The authentication method is not specified in this document.

[7] Encryption Key Indication

BS transfers the encryption key to MS.

[8] Connection Response

BS notifies MS Connection-ID, QCS information, etc.

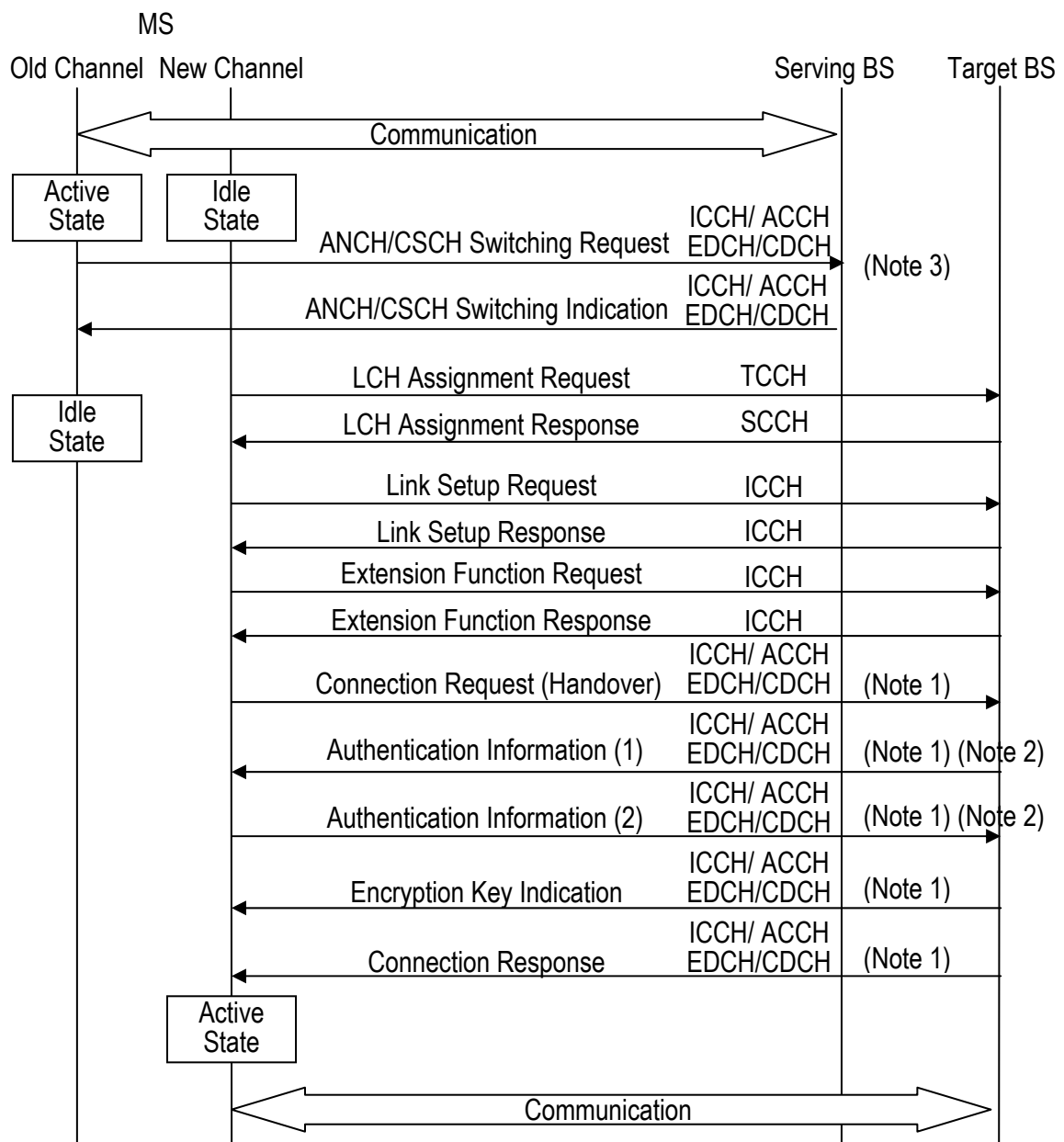

Figure 8.13 Normal Handover Triggered by MS Sequence

Note 1 When control data is transmitted with EDCH/CDCH/ICCH, the CD bit of the MAC header is set as 00 or 01.

Note 2 This is one example for the authentication sequence.

Note 3 Normal handover is performed when MS cannot find any target BS-info or communication quality degradation.

8.2.6.3 Seamless Handover

Figure 8.14 shows the seamless handover sequence.

The control order is as follows:

[1] TDMA Slot Limitation Request

To search BS in the surrounding, MS transmits "TDMA slot limitation request" message to BS and makes the slot vacant. Then MS searches for other BSs in the surrounding.

[2] ANCH/CSCH Switching Request and Response

MS sends "ANCH/CSCH switching request" message and indicates target BS to serving BS. Serving BS requests slot to target BS, and target BS responds slot to serving BS. Serving BS then sends "ANCH/CSCH switching indication" message to MS and indicates handover to target BS.

[3] LCH Assignment Request and Response

MS requests LCH assignment to BS by sending "LCH assignment request" message on TCCH, and BS assigns a LCH by sending "LCH assignment response" message on SCCH.

[4] Link Setup Request and Response

MS performs carrier sensing for the assigned LCH channel. MS notifies the start of communication by sending "link setup request" message when it judges that this assigned channel is not interfered and available. In this message, MS also notifies BS of the communication ability, MSID etc. BS notifies MS of the function to use in this communication by sending "link setup response" message.

[5] Extension Function Request and Response

When the extra function of this LCH is necessary to be negotiated or changed, the content of the function change is notified with "extension function request and response" message. This message can be omitted if it is not necessary. It is notified with "extension function request" message when necessary.

[6] Connection Request

MS notifies the type of QoS connection to BS. The connection type in this case is handover.

[7] Authentication

The authentication information is transmitted between BS and MS when it is necessary in this sequence. The authentication method is not specified in this document.

[8] Encryption Key Indication

BS transfers the encryption key to MS.

[9] Connection Response

BS notifies MS of Connection-ID, QCS information, etc.

[10] Connection Release

After MS performed handover and transited to the active state, MS or BS sends "connection release" message and radio connection is released.

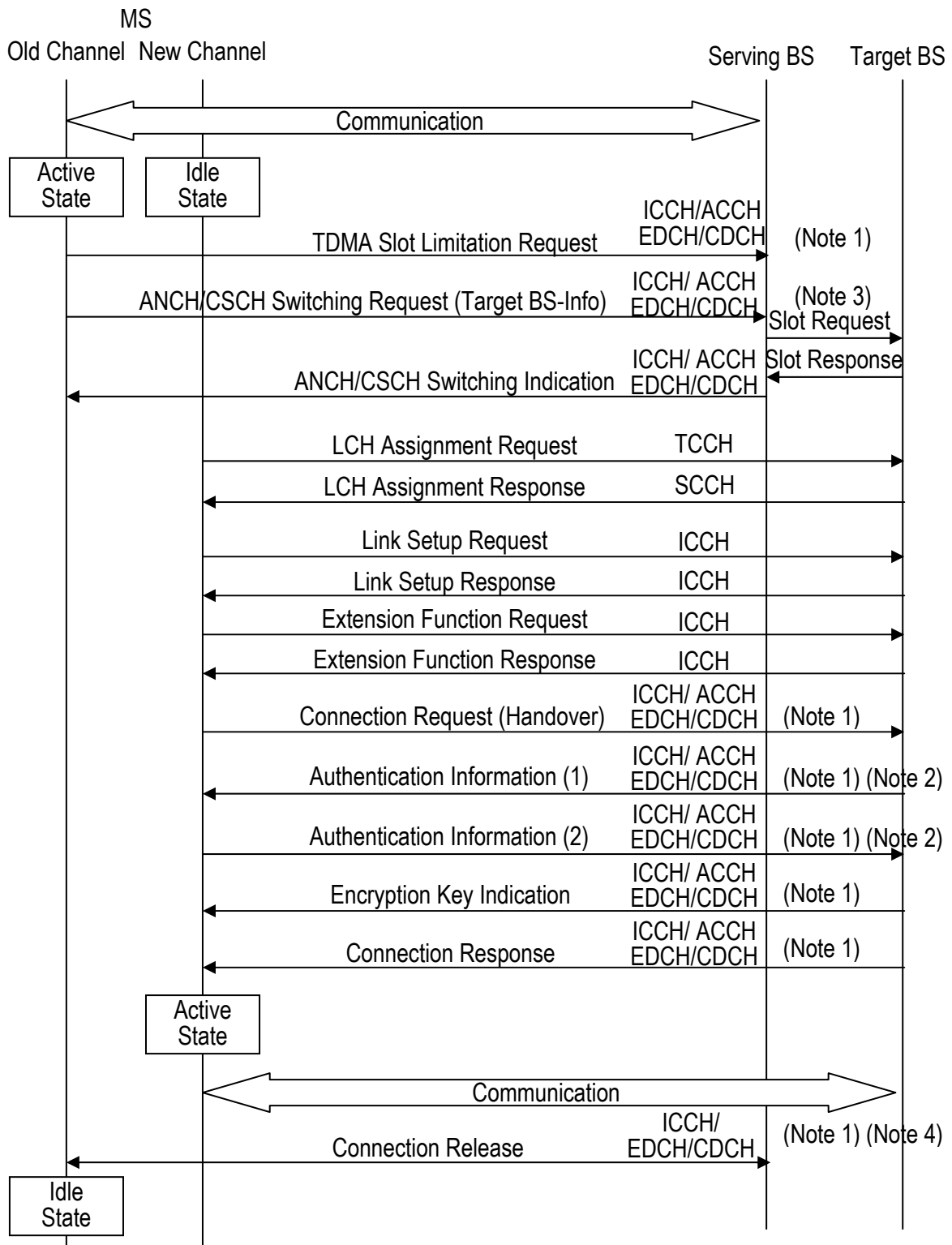

Figure 8.14 Seamless Handover Sequence

Note 1 When control data is transmitted with DCH, the CD bit of the MAC header is set as 00 or

01.

Note 2 This is one example for the authentication sequence.

Note 3 Seamless handover is done when there is target BS-info and the communication quality degrades.

Note 4 After MS performed handover and transit to active state, MS or BS sends "connection release" message and radio connection is released.

8.2.7 Link Channel Establishment

8.2.7.1 Link Channel Assignment

Figure 8.15 shows LCH assignment response sequence.

MS requests LCH assignment to BS by sending "LCH assignment request" message on TCCH. BS sends "LCH assignment response" message on SCCH when it cannot assign LCH.

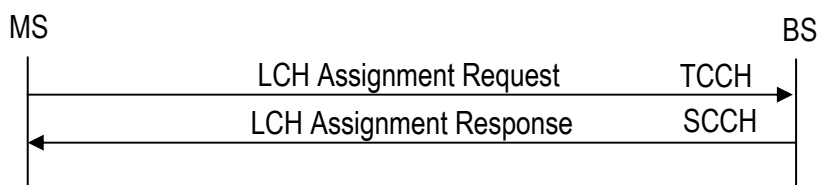

Figure 8.15 Link Channel Assignment Response Sequence

8.2.7.2 Link Channel Assignment Standby

Figure 8.16 shows LCH assignment request, standby and response sequence.

MS requests LCH assignment to BS by "LCH assignment request" message on TCCH, when BS cannot assign LCH temporarily, BS suspends assignment of LCH, and BS sends "LCH assignment standby" message on SCCH. When BS is ready to assign LCH, BS assigns LCH by "LCH assignment response" message on SCCH.

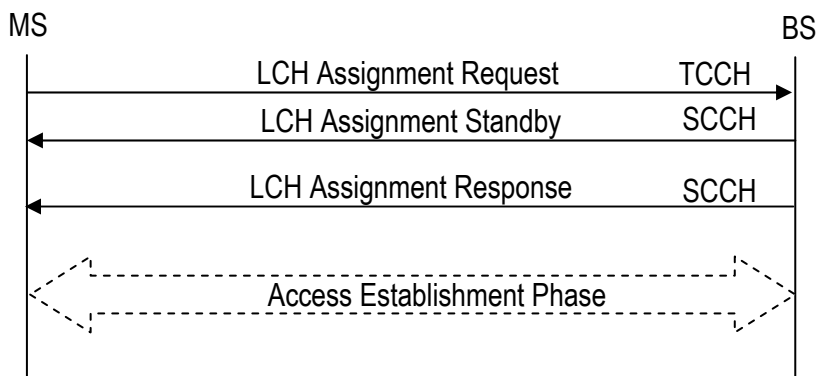

Figure 8.16 Link Channel Assignment Standby Sequence

8.2.7.3 Link Channel Re-request Sequence

Figure 8.17 shows LCH assignment re-request sequence.

MS requests LCH assignment to BS by sending "LCH assignment request" message on TCCH. After BS assigns LCH by sending "LCH assignment response" message, MS sends "LCH assignment re-request" message when it requests the assigned LCH to change to another LCH (e.g.: DL carrier sensing NG, etc). Then, BS assigns another LCH by sending "LCH assignment response" message.

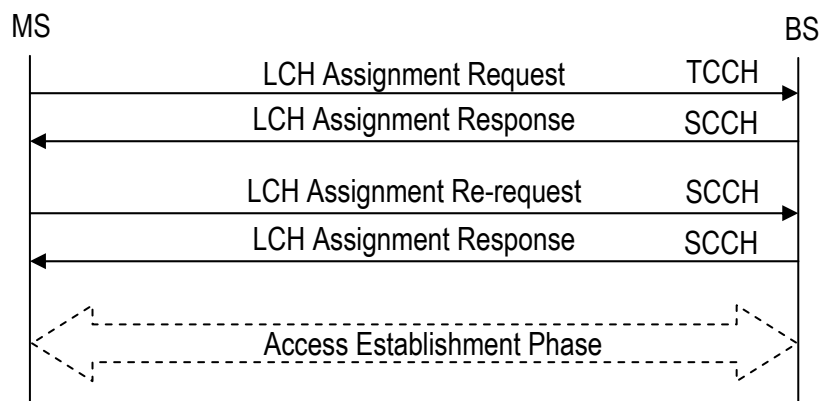

Figure 8.17 Link Channel Assignment Re-request Sequence

8.2.7.4 Link Channel Request Standby and Link Channel Assignment Re-request

Figure 8.18 shows LCH request standby and LCH assignment re-request sequence.

MS requests LCH assignment to BS by sending "LCH assignment request" message on TCCH. BS suspends assignment of LCH when it cannot assign LCH temporarily and sends "LCH assignment standby" message on SCCH. BS assigns LCH by "LCH assignment response" message on SCCH when it is ready to assign LCH. When MS requests assigned LCH to change to other LCH (e.g.: DL carrier sensing NG, etc), MS sends "LCH assignment re-request" message. BS will then assign another LCH by sending "LCH assignment response" message.

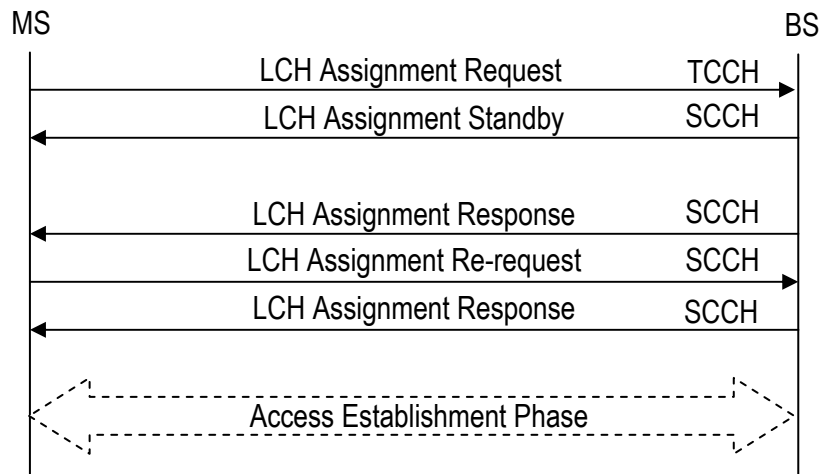

Figure 8.18 Link Channel Assignment Standby and Link Channel Assignment Re-request Sequence

8.2.7.5 Link Channel Assignment Rejection

Figure 8.19 shows LCH assignment rejection sequence.

MS requests LCH assignment to BS by sending “LCH assignment request” message on TCCH. BS sends “LCH assignment reject” message on SCCH when it cannot assign LCH.

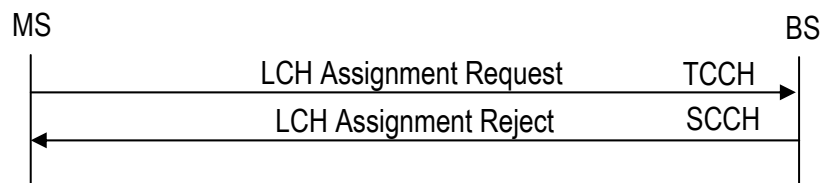

Figure 8.19 Link Channel Assignment Rejection Sequence

8.2.8 Additional QCS

8.2.8.1 Additional QCS

Figure 8.20 shows the additional QCS sequence.

MS sends “additional QCS request” message when it requests new QCS. BS assigns new QCS by sending “additional QCS response” message.

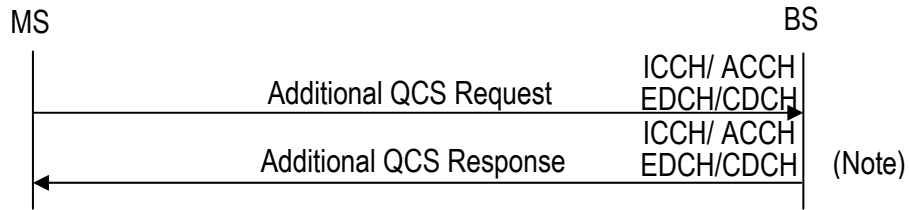

Figure 8.20 Additional QCS Sequence

Note BS sends “additional LCH indication” message or “additional QCS response” message when it received “additional QCS request” message from MS, according to the state of communication.

8.2.8.2 Additional QCS Request Indication

Figure 8.21 shows the additional QCS request indication sequence. BS indicate to transmit “additional QCS request” message to MS. MS sends “additional QCS request” message when it requests new QCS. BS assigns new QCS by sending “additional QCS response” message.

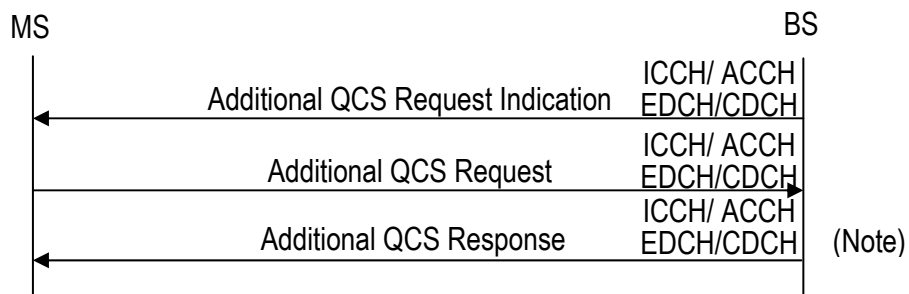

Figure 8.21 Additional QCS Request Indication Sequence

Note BS sends “additional LCH indication” message or “additional QCS response” message when it received “additional QCS request” message from MS, according to the state of communication.

8.2.8.3 Additional QCS Rejection

Figure 8.22 shows additional QCS rejection sequence. MS sends “additional QCS request” message when it requests new QCS. BS sends “additional QCS rejection” message as response when it cannot assign specified QCS.

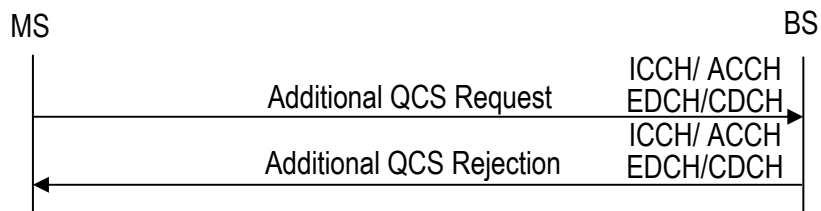

Figure 8.22 Additional QCS Sequence

8.2.8.4 Additional QCS with Extra LCH

Figure 8.23 the sequence to obtain the additional QCS with extra LCH.

MS sends “additional QCS request” message when it requests new QCS. BS sends “additional LCH indication” message when it needs LCH assignment in order to assign new QCS. MS sends “additional LCH confirmation” message to new added channel and establishes new LCH. BS then assigns new QCS on this LCH.

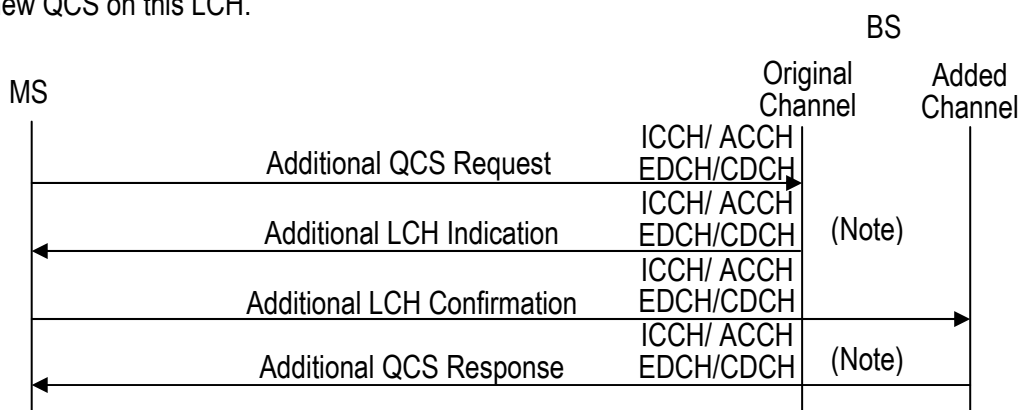

Figure 8.23 Additional QCS made through increasing LCH Sequence

Note BS sends “additional LCH indication” message or “additional QCS response” message on receiving “additional QCS request” message, according to the state of communication..

8.2.8.5 Additional QCS with Re-request of Extra LCH

Figure 8.24 shows the sequence to obtain the additional QCS with re-request of extra LCH.

MS sends “additional QCS request” message when it requests new QCS. BS sends “additional LCH indication” message when it needs LCH assignment in order to assign new QCS. MS sends “LCH assignment re-request” message when it requests assigned LCH to change to another LCH (e.g.: DL carrier sensing NG, etc). Then, BS assigns another LCH by sending “LCH assignment response” message. MS sends “additional LCH confirmation” message to new added channel and establishes new LCH. BS then assigns new QCS on this LCH.

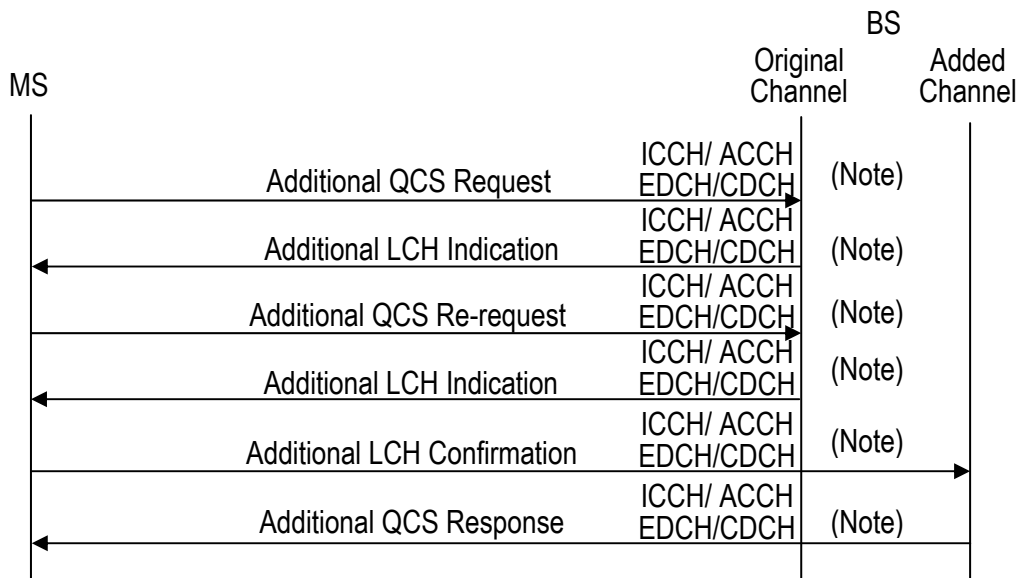

Figure 8.24 Additional QCS with Re-request of Extra LCH Sequence

Note BS sends “additional LCH indication” message or “additional QCS response” message, on receiving “additional QCS request” message, according to the state of communication.

8.2.9 Status Check

Status check is used to check Connection-ID and QCS-ID in BS and MS.

8.2.9.1 QCS Status Check Triggered by MS

Figure 8.25 shows status check triggered by MS sequence.

MS sends “QCS status enquiry request” message to BS to check the status, and BS answers the status by sending “QCS status enquiry response” message.

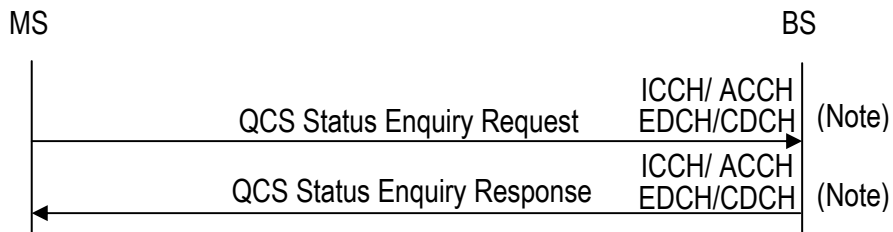

Figure 8.25 QCS Status Check Triggered by MS

Note When control data is transmitted with EDCH/CDCH/ICCH, the CD bit of the MAC header is set as 00 or 01.

8.2.9.2 QCS Status Check Triggered by BS

Figure 8.26 shows status check triggered by BS sequence. BS sends “QCS status enquiry request” message to MS to check the status, and MS answers the status by sending “QCS status enquiry response” message.

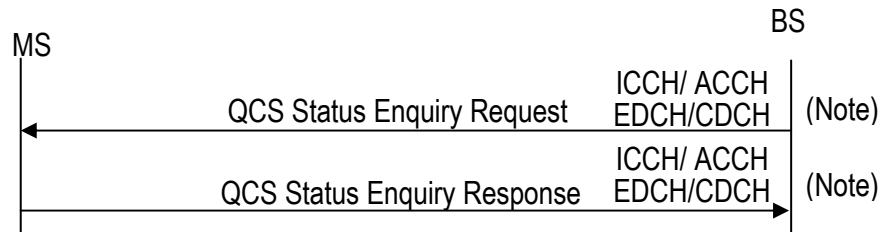

Figure 8.26 QCS Status Check Sequence Triggered by BS

Note When control data is transmitted with EDCH/CDCH/ICCH, the CD bit of the MAC header is set as 00 or 01.

8.2.10 CQI Transmission

8.2.10.1 CQI Report

Figure 8.27 shows CQI report from MS sequence. MS sends “CQI report” message to BS autonomously.

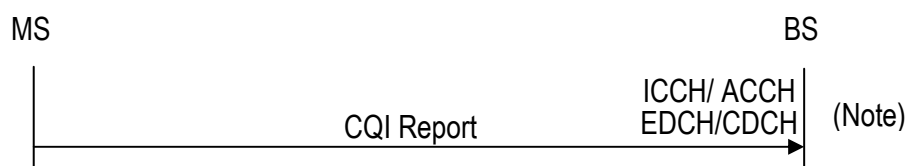

Figure 8.27 CQI Report Sequence

Note When control data is transmitted with EDCH/CDCH/ICCH, the CD bit of the MAC header is set as 00 or 01.

8.2.10.2 CQI Report Indication

Figure 8.28 shows “CQI request” message from BS sequence. BS sends “CQI report indication” message to MS, and MS answers the CQI by sending “CQI report” message.

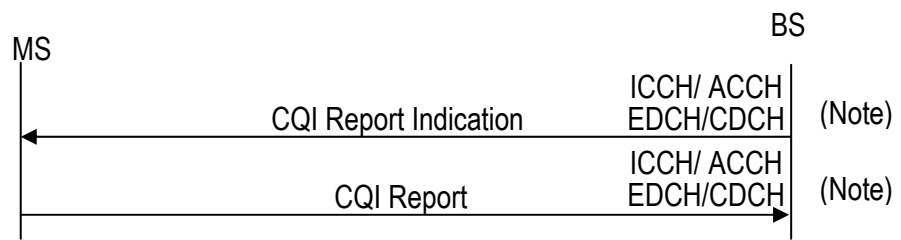

Figure 8.28 CQI Report Indication Sequence

Note When control data is transmitted with EDCH/CDCH/ICCH, the CD bit of the MAC header is set as 00 or 01.

Chapter 9 Access Phase

9.1 Overview

In this chapter, service channel specification in access phase is described. This is the phase after the establishment of access and the phase for several communication controls and the communication service. Voice and data communication is realized by the service channel on those established radio link channel. Section 9.4 - 9.6 are written for reference, and supplementary information.

9.2 Retransmission Control Method

9.2.1 ARQ

9.2.1.1 Procedure of ARQ

PHY layer recognizes the PHY data unit (CRC section) for every user based on the information on the PRU assigned by MAC layer. ARQ is performed by the PHY data unit. This section describes (selective repeat) SR type ARQ. In SR type ARQ, a resending control part resends the error data in the following procedure: The receiving side will transmit NACK if CRC error is detected after receiving data. The transmitting side recognizes the reason by which the error has occurred and resends the data.

9.2.1.2 Setting the Timing for Transmission of the ACK Field in CDCH

Figure 9.1 shows the send timing of ACK. The ACK field is set at 7.5 ms after CDCH received data.

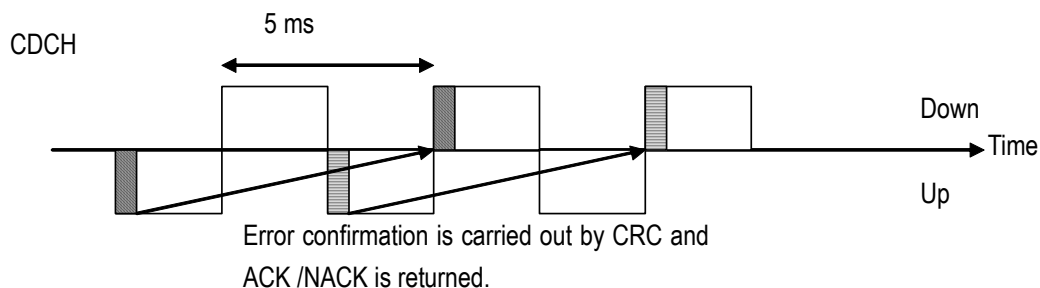

Figure 9.1 ACK Sending Timing

9.2.1.3 Timing of Retransmission

Figure 9.2 shows ARQ re-sending timing when the right of communication is continuously granted to MS. MS will transmit NACK of CDCH after 7.5 ms, if the data error of 2 is detected. BS recognizes an error on receiving NACK and, re-sends 2' to MS on DL CDCH after 7.5 ms.

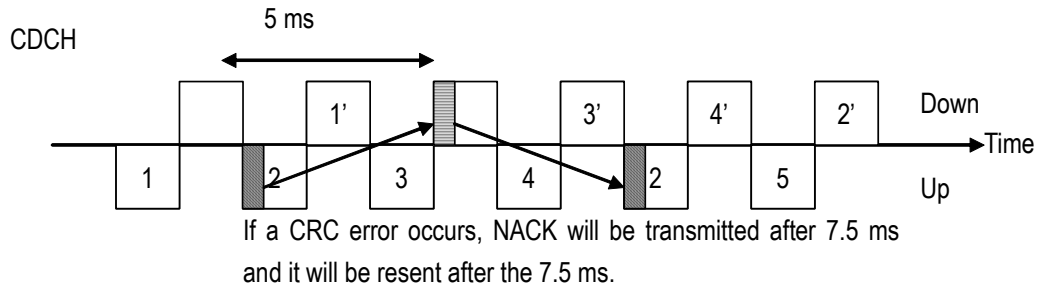

Figure 9.2 ARQ Retransmission Timing

9.2.1.4 Example of ARQ Retransmission

The example of resending an ARQ is introduced in this section.

Figure 9.3 shows the example of resending in case that the same data serve as an error continuously. Data are re-sent to the specified retry count. Moreover, continuous data are transmitted except for resending.

Figure 9.4 shows the example of resending in case that continuous different data serve as an error. Since resending control is carried out by the same time relation, even if data 2 and 3 are continuous data, they are resent independently.

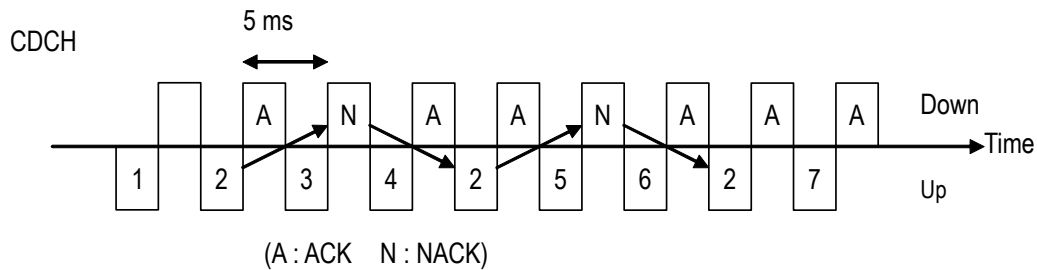

Figure 9.3 Example of ARQ Retransmission 1

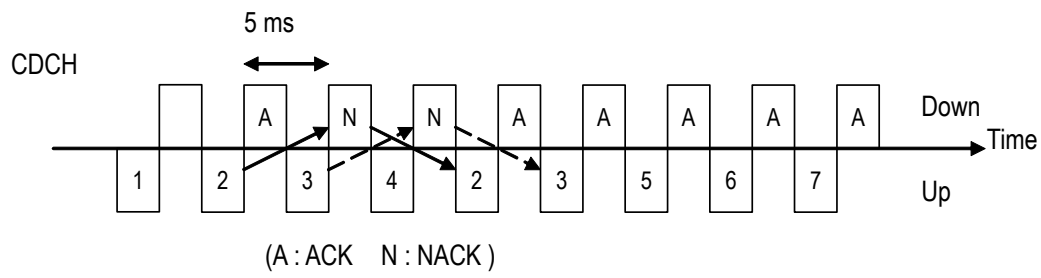

Figure 9.4 Example of ARQ Retransmission 2

9.2.1.5 Example of Sequence

Figure 9.5 shows the example of UL ARQ sequence.

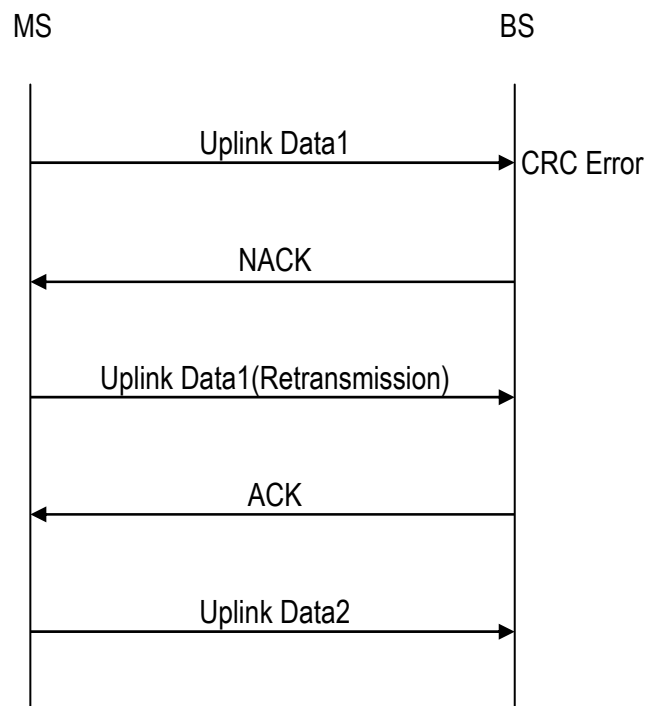

Figure 9.5 Example of UL

9.2.1.6 About the Switch of ARQ and the Adaptive Modulation

This section describes the way to switch ARQ and adaptive modulation. Transmission side changes modulation class when the CRC error exceeds the defined limit of X times. Upper layer decides the limit of X according to QoS etc.

9.2.2 HARQ

9.2.2.1 Procedure of HARQ

PHY Layer receives a set of PHY header and a set of PHY payload units on a TDMA frame, identifies the users for these data units according to the MAP information provided by the MAC and performs HARQ on the received PHY data units. Chase combining is described as follows as one method of HARQ. Figure 9.6 shows the block diagram of the HARQ receiver. HARQ procedure is described as follows:

1. FFT operation is performed on the received base band signal The user signal is detected by FFT operation.
2. De-interleaving operation is performed and buffered on the detected user signal. No maximum ratio combining is done for the first time. De-interleaving operation is only applied after retransmitted data for NACKs is received.
3. The buffer is released if no error is detected. The ACK field is set accordingly on the ANCH channel's PHY Header. The transmission timing of this ANCH is explained in the next chapter.
4. The reception buffer will not be released if an error is detected. The buffered data will be kept in the buffer until the reception of the retransmitted data. [Retransmission timing of the retransmitted data will be explained later.]. The NACK is set for the erroneous data in the ACK field of the PHY header and transmitted on the ANCH channel. The timing of the ANCH channel transmission is the second TDMA frame after the current frame.
5. NACK will be transmitted to the transmitting side if an error is detected. When the retransmitted data is received, the FFT operation is performed on the received signal and then de-Interleaving operation is conducted to the detected user signal. The de-Interleaved data is combined with the buffered data. The Error correction is performed on the combined data and then error detection will be performed. The process from FFT operation to error detection will be done when HARQ condition is satisfied. The condition is described in Section 9.2.2.3.

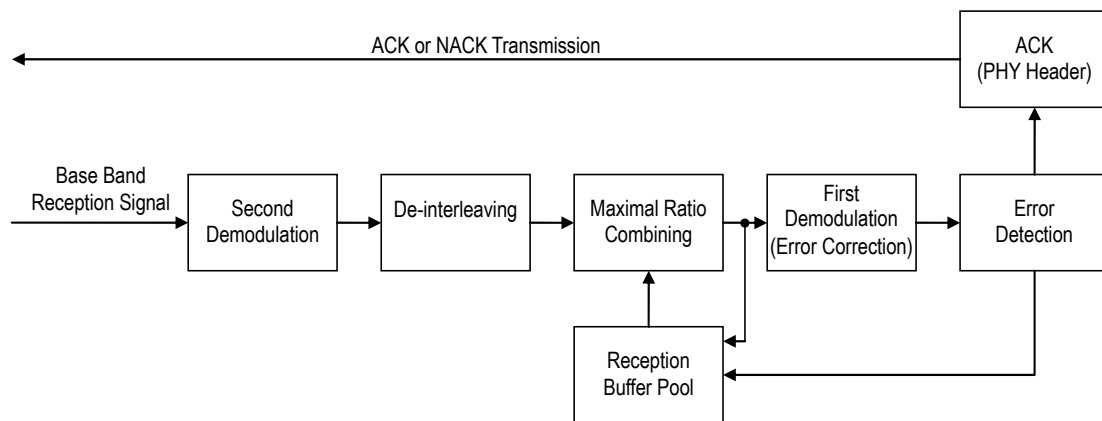

Figure 9.6 Reception of Block Diagram of HARQ

9.2.2.2 Retransmission Rule in FM-Mode

When EXCHs are retransmitted in FM-mode, the retransmission is done with the following rule.

- EXCHs in the same slot as the first transmission are used in HARQ retransmission.
- EXCHs with smaller logical PRU number are firstly used for HARQ retransmission and remaining EXCHs are used for new data transmission.
- The number of EXCH used for retransmission does not change in HARQ retransmission. When the original data size is one/two EXCHs, retransmission data size is also one/two EXCHs, respectively.

Figure 9.7 shows an example of retransmission control. PHY data unit size does not change and the data is transmitted first in a slot in HARQ retransmission. It also shows the relationship between logical PRU assignment and symbol mapping method.

In the first transmission, Data 1 is transmitted by EDCH 1 which combined EXCH 1 and EXCH 2. Data 2 is transmitted by EDCH 2 which combined EXCH 3 and EXCH 4. Data 3 is transmitted by EDCH 3 which combined EXCH 5 and EXCH 6. And Data 4 is transmitted by EDCH 4 which consists of only EXCH 7. Data 2 and Data 4 are retransmitted when an error occurs in communication of EDCH 2 and EDCH 4. By the first and the second rule, Data 2 is retransmitted by EDCH 1 which combined EXCH 1 and EXCH 2. According to the first, the second and the third rule, Data 4 is retransmitted by EDCH 3 which consists of EXCH 5. EXCH 3, EXCH 4, EXCH 6, and EXCH 7 which are not used by retransmission will then combine each other to form EDCH 2 and EDCH 4. Data 5 and Data 6 which are ready for transmission for the first time, will be sent by EDCH 2 and EDCH 4.

Logical PRU assignment

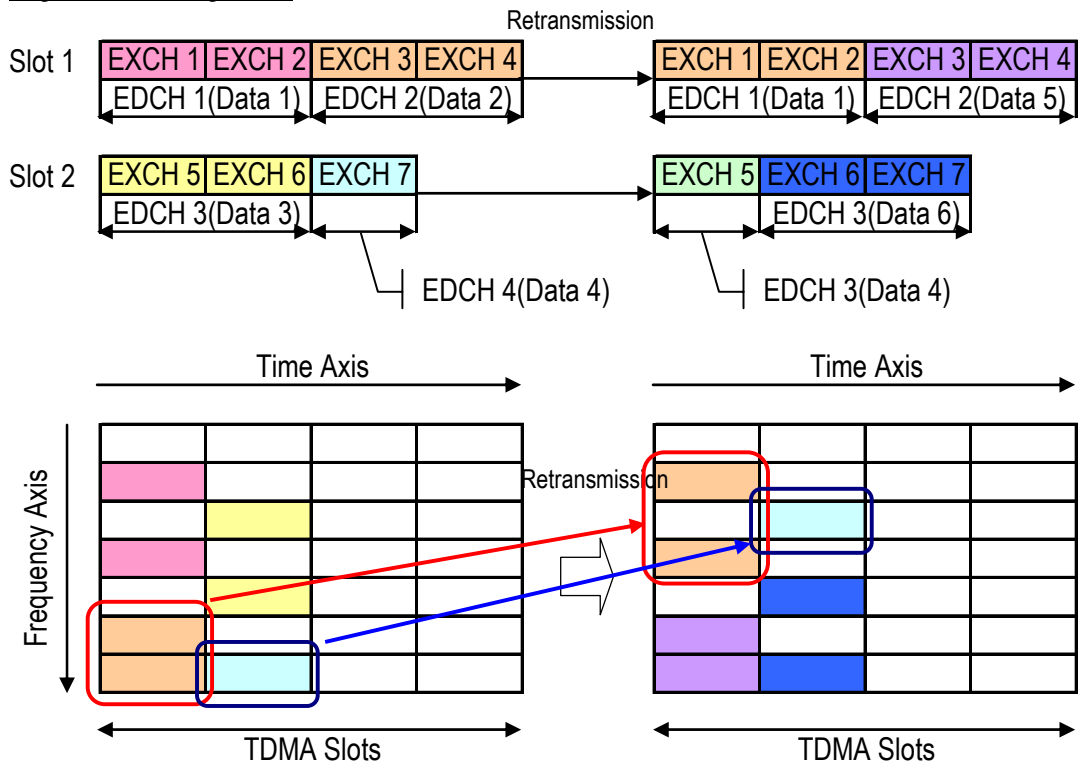

Symbol Mapping Method

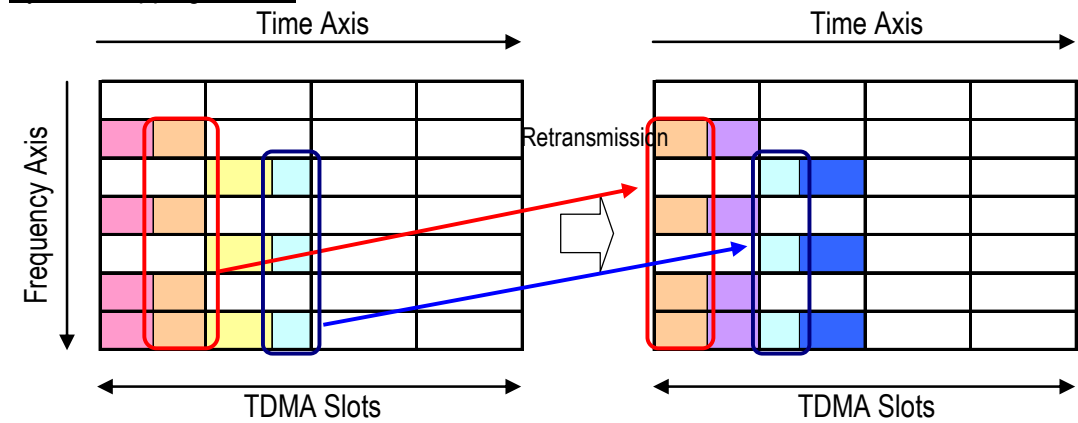

Figure 9.7 Example of Retransmission Control

9.2.2.3 HARQ Approval Condition

It is necessary to assign enough number of PRU to retransmit PHY data unit. The same MCS and slot shall be used for the retransmission of the PHY data unit. If these conditions are not satisfied, HARQ information will be released.

As an example, assume that ANCH, EXCH1, EXCH2, EXCH3 and EXCH4 are allocated for a user. When NACK is received for a particular MAC frame, and two EXCHs are required for retransmission, MAC will then request PHY layer to use the first two EXCHs given by the MAP field for the retransmission.

When the NACK is received for multiple MAC frames simultaneously, the first MAC frame will be allocated to the first few available EXCHs which are indicated by MAP field.

When the NACK is received for multiple MAC frames simultaneously, MAC will then try to allocate EXCHs for the transmission of all the MAC frames. MAC will allocate as many EXCHs as possible for frame transmission in case that sufficient EXCHs are not available.

Remaining MAC frames will be retransmitted by MAC-ARQ in the future.

9.2.2.4 HARQ Cancel Condition

HARQ cancel condition and the process are shown in [Table 9.1](#). These conditions have a priority numbered from 1 to 5. If some conditions occurred at the same time, higher priority condition should be taken into use.

Table 9.1 Summary of HARQ Cancel Condition

No.	Condition	Outline of Process
1	Received ANCH is CRC error or ICCH format.	The HARQ retransmission data in the frame should be cleared, and notify the other side that ANCH is CRC error by HC=1.
2	Received ANCH is set HC=1.	The HARQ retransmission data in the frame should be cleared
3	There is no PRU in the slot which has the HARQ retransmission data.	The HARQ retransmission data in the slot should be cleared.
4	There is the difference of MI between before and after retransmission.	The HARQ retransmission data in the MI applicable to slot should be cleared.
5	There are not enough number of PRU for HARQ retransmission data unit.	The PHY data unit which can not be retransmitted should be cleared.

9.2.2.5 Setting the Timing for the Transmission of the ACK Field in the ANCH

This section will describe the timing setting for the transmission of the ACK field on the ANCH. EXCHs are receiving data during the DL part of the current TDMA frame. After that, the received data will be forwarded to perform various operations like receiving block diagram in Figure 9.6. Therefore, it is impossible to send the ACK for the received data in the UL part of the next TDMA frame. The ACK or NACK for received data will be sent on the UL part of the TDMA frame after the next one.

The example when ANCH is at the first slot is shown in Figure 9.8 and the example when ANCH is at the 4th slot is shown in Figure 9.9.

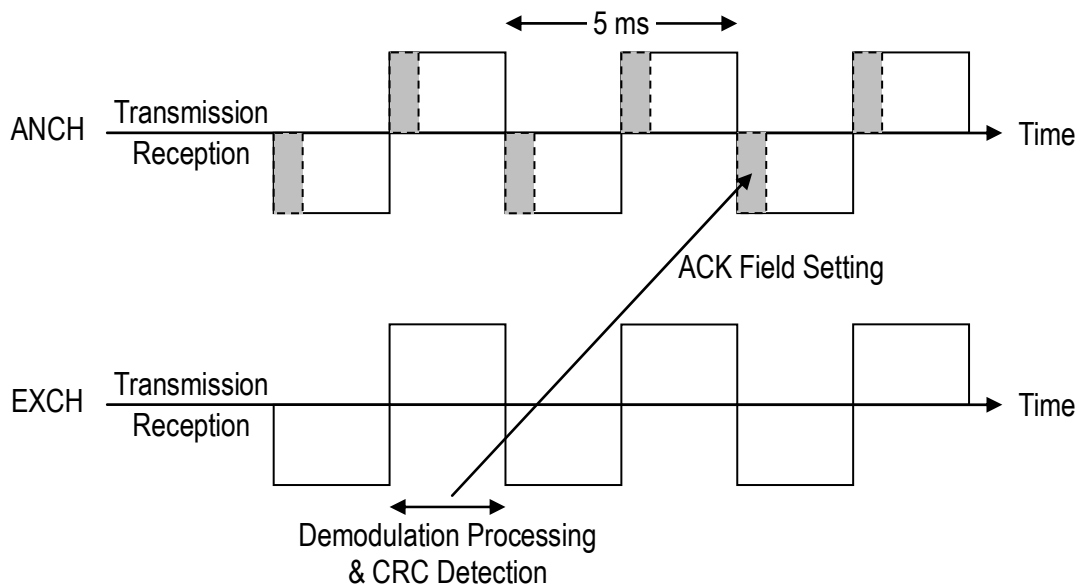

Figure 9.8 ACK Setting Timing When ANCH at the First Slot

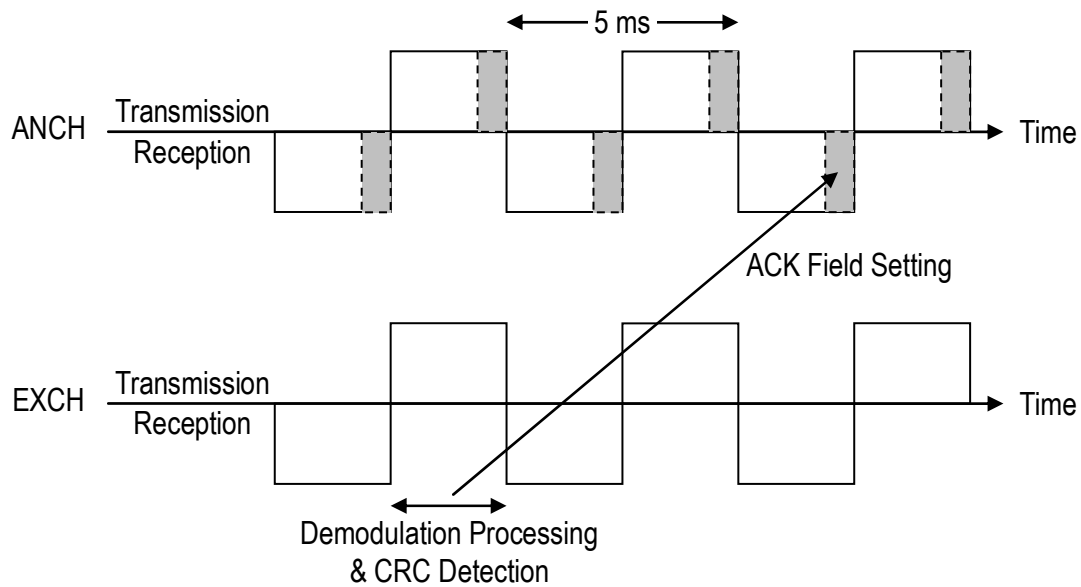

Figure 9.9 ACK Setting Timing When ANCH at the Last Slot

9.2.2.6 Timing of Retransmission

The timing of the retransmission of HARQ is different. It depends on the performance of MS. Therefore, negotiation has to happen between the MS and BS before the connection is established.

9.2.2.6.1 HARQ Retransmission Timing for High Performance MS

Figure 9.10 shows the HARQ timing for the high performance MS. This figure shows the allocation of EXCH on all the TDMA frames for the MS. In this case, the responses can be sent or received in the adjacent TDMA frames. Firstly, MS detect an error on DL Slot 1' (refer to the figure). Next, NACK is sent after 7.5 ms on the ANCH. Then, BS allocates the required EXCHs after receiving the NACK. The EXCHs will be intimated to MS through MAP of ANCH after 7.5 ms from the time of reception of the NACK. In the next TDMA frame, the BS will then retransmit the Data 1' to MS. MS will keep the HARQ information until it receives the MAP information in case that the BS cannot allocate the EXCHs for Data 1' temporarily. MS receives the Data 1' after 5 ms, that is, in the next TDMA frame after receiving the MAP from BS.

Here, HARQ information stands for the ACK/NACK discrimination at the data sending node and the I/Q pattern [Erroneous data set, which will be used at the time of chase combining, is stored in the buffer] when error happens. BS detected error for the UL Data 1 as shown in the diagram. NACK will be sent to MS after 12.5 ms. At the same time, BS will allocate the required EXCHs and informs it to MS through the MAP field of the ANCH in the same DL data TDMA frame. After 2.5 ms, the MS will retransmit the Data 1 according to the MAP field received from BS. In case when BS cannot allocate EXCHs for the MS for retransmission, it will keep HARQ information until the resources are available for allocation. MS will wait till it receives MAP from BS retransmit

the Data 1 immediately after 2.5 ms.

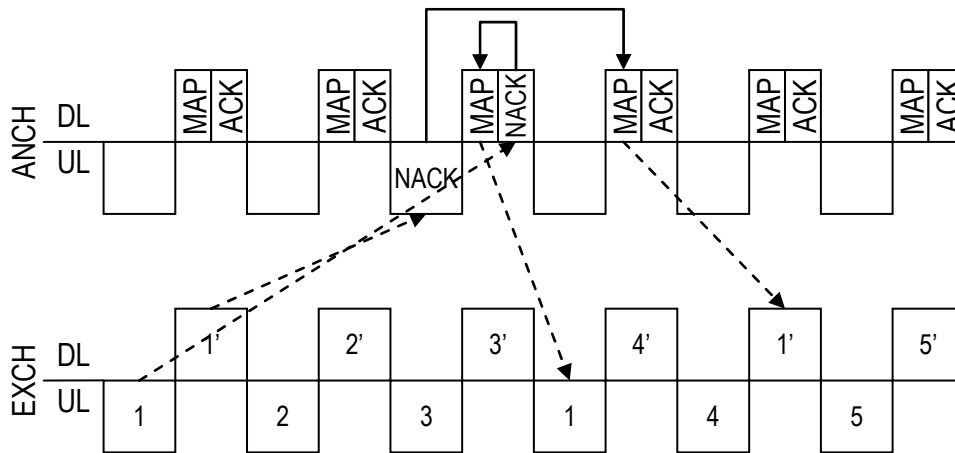

Figure 9.10 HARQ Retransmission Timing with Early Response

9.2.2.6.2 HARQ Retransmission Timing for Low Performance MS

Figure 9.11 shows the HARQ timing for the low performance MS. This figure shows the allocation of EXCH on all the TDMA frames for the MS.

Firstly, MS detected an error on DL Slot 1'. Next, NACK is sent after 7.5 ms on the ANCH. Then, BS allocates the required EXCHs on receiving the NACK. They will be intimated to MS through MAP of ANCH after 7.5 ms from the time of reception of the NACK. The BS will retransmit the Data 1' to MS after 10 ms. MS will keep the HARQ information until it receives the MAP information if the BS cannot allocate the EXCHs for Data 1' temporarily. MS receives the Data 1' after 10 ms that is, in the second TDMA frame, after receiving the MAP from the BS. BS detects error for the UL Data 1 as shown in the diagram. NACK will be sent to MS after 12.5 ms. Meanwhile, BS will allocate the required EXCHs and inform it to MS through the MAP field of the ANCH in the same DL data TDMA frame. After 7.5 ms, the MS will retransmit the Data 1 according to the MAP field received from BS. In case when BS cannot allocate EXCHs for the MS for retransmission, it will keep HARQ information until the resources are available for allocation. MS will wait till it receives MAP from BS to retransmit the Data 1 immediately after 7.5 ms.

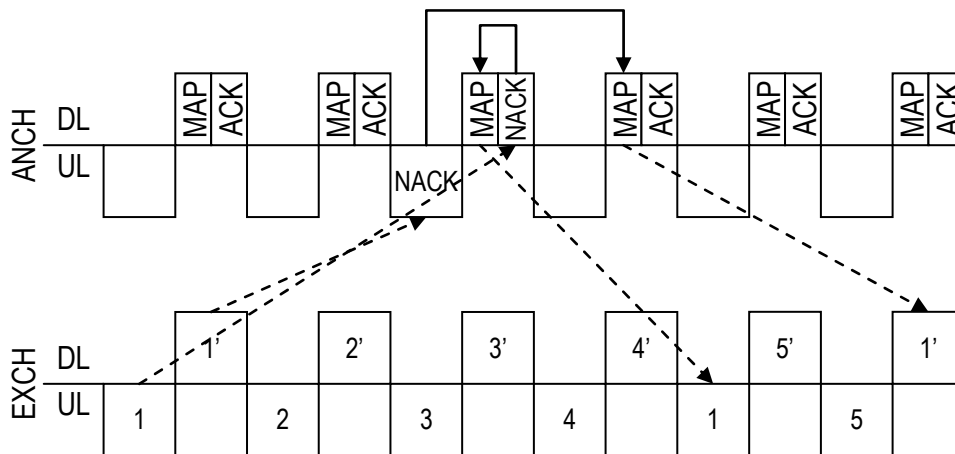

Figure 9.11 HARQ Retransmission Timing with Slow Response

9.2.2.7 Example of HARQ Retransmission

Example of HARQ retransmission is as shown in the below.

In Figure 9.12, the example of retransmitting the Data 1 repeatedly when the error happens continuously is shown. In the Figure 9.12, the upper part shows the detail of ANCH and the lower part shows the detail of EXCH. The retransmission of the Data 1 will be repeated until the retransmission counter [As specified] becomes 0. In between two retransmission periods of Data 1, the EXCHs can be used to transmit other data if the BS allocates EXCHs through the MAP.

In Figure 9.13, the example of retransmitting the Data 1 and Data 2 when error happens to both data is shown. Both Data 1 and Data 2 are subject to the same rule for retransmission. That is, Data 1 is retransmitted after 2.5 ms from the time of receiving the NACK. On the other hand, Data 2 is retransmitted in a similar way but independently.

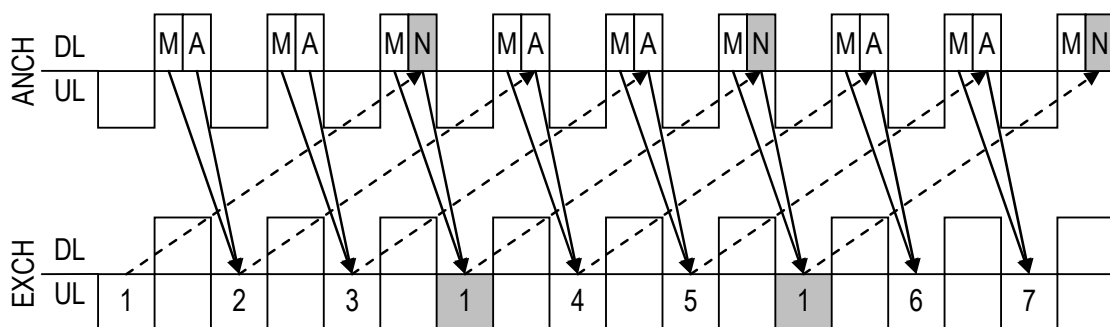

Figure 9.12 Example of HARQ Retransmission 1

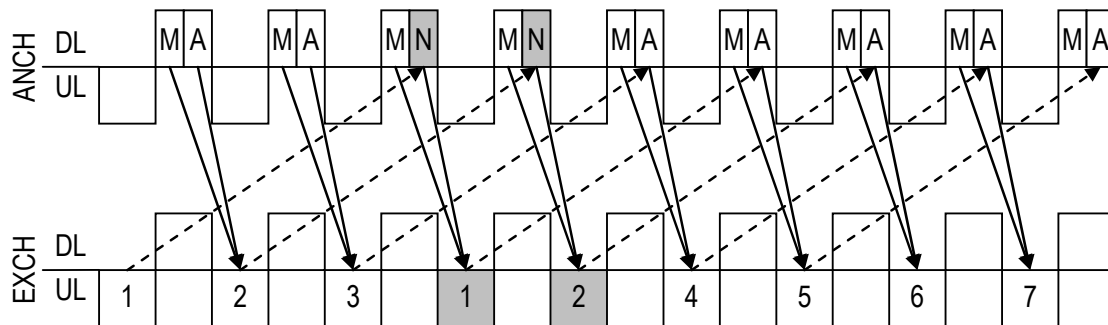

Figure 9.13 Example of HARQ Retransmission 2

9.2.2.8 Example of Sequence

Figure 9.14 and Figure 9.15 show the example of the sequence of UL HARQ.

UL example 1 is an example of normal HARQ sequence when the error occurs.

UL example 2 is a sequence example when the error occurs after MCS is changed at the next transmission timing. In this case, the data 1 is usually demodulated because it does not meet the HARQ approval requirement, and the buffering data for HARQ should be cleared at that timing.

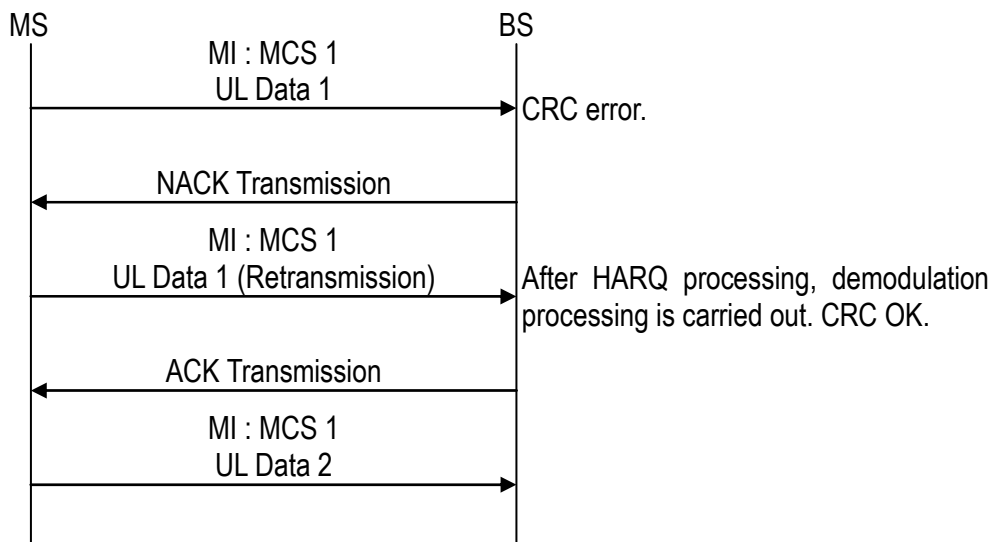

Figure 9.14 Example of UL 1

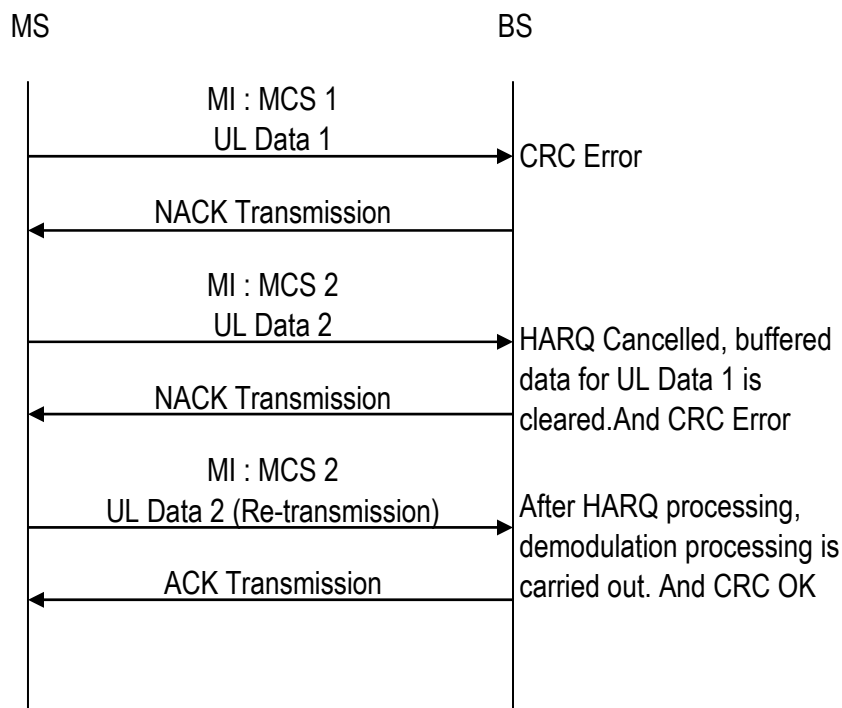

Figure 9.15 Example of UL 2

9.2.2.9 Switch of HARQ and the Adaptive Modulation

This section describes to the way to switch HARQ and adaptive modulation. When the CRC error occurs repeatedly, transmission side changes modulation class and retransmits data by MAC-ARQ.

9.2.2.10 Increment Redundancy (IR) Method

IR-HARQ is used as a HARQ method. Figure 9.16 shows the block diagram of the IR-HARQ receiver. IR-HARQ procedure is as follows:

1. FFT processes the baseband reception signal and the user signal is detected.
2. De-interleaving processes detected user signal and the result data is buffered. The process of maximum ratio combining is not performed for the first time. Depending on the buffer size and the base codeword length, maximum ratio combining is used only when the total received data exceeds IR length (M_R).
3. The buffer is released if no error is detected. The ACK field is set accordingly on the PHY.
4. The reception buffer is not released if an error is detected. The buffered data is kept in the buffer until the retransmitted data is received. [Retransmission timing of the retransmitted

data is described later.]. The NACK is set for the erroneous data in the ACK field of the PHY header and transmitted on the ANCH. The timing of the ANCH transmission is the second from the current TDMA frame.

5. The previous sequential signal is transmitted when the transmitter receives NACK. If total transmitted data exceeds M_R , the data transmitted previously is retransmitted.
6. When the retransmitted data is received, FFT processed the received signal and de-interleaving processes the detected user signal. The de-interleaved data is concatenated to the buffered data if total transmitted data is less than or equal to M_R . If total transmitted data exceeds M_R , the de-interleaved data is combined with the buffered data as CC. Figure 9.17 shows the example of IR-HARQ retransmission procedure. The error correction processes the combined data first and error detection is performed afterwards.

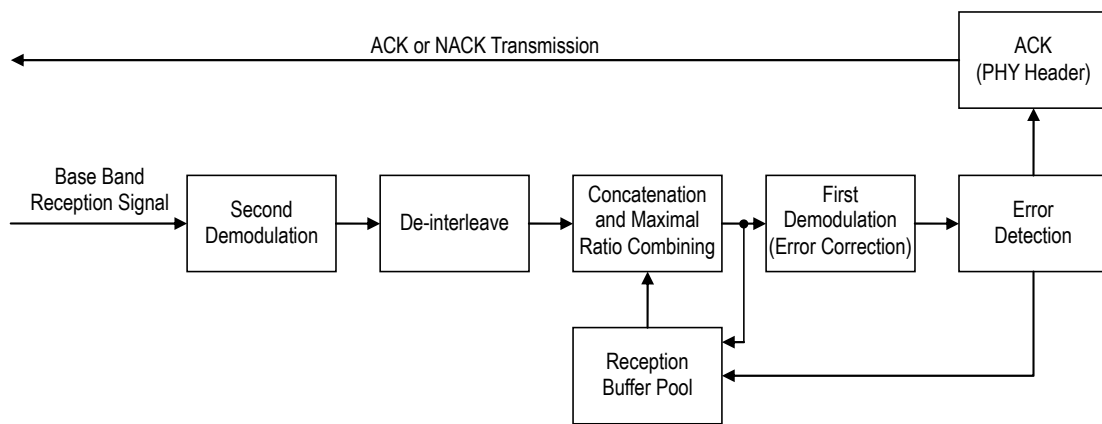

Figure 9.16 Reception Block Diagram of IR-HARQ

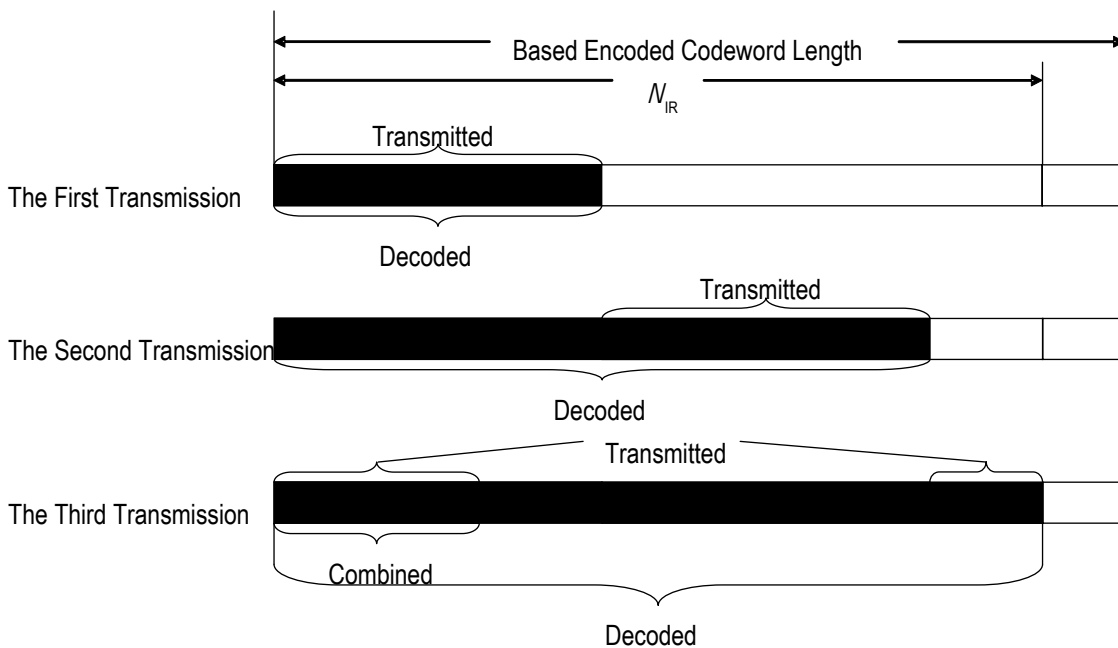

Figure 9.17 IR-HARQ Retransmission Procedure

9.2.2.11 Retransmission Count

HARQ retransmission time is separately specified. When the condition of HARQ retransmission is satisfied, the number of HARQ retransmission is counted.

9.3 QCS and Connection

Figure 9.18 shows the relation between connection and QCS. The connection is related to unit radio resource. The radio resource is composed of CSCH or the pair of ANCH and EXCH. One connection accommodates one or more QCS. QoS is controlled for each QCS. One MS can have two or more connections. Detail of QoS is described in the following section. The connection is identified by connection-ID. The QCS is identified by QCS-ID.

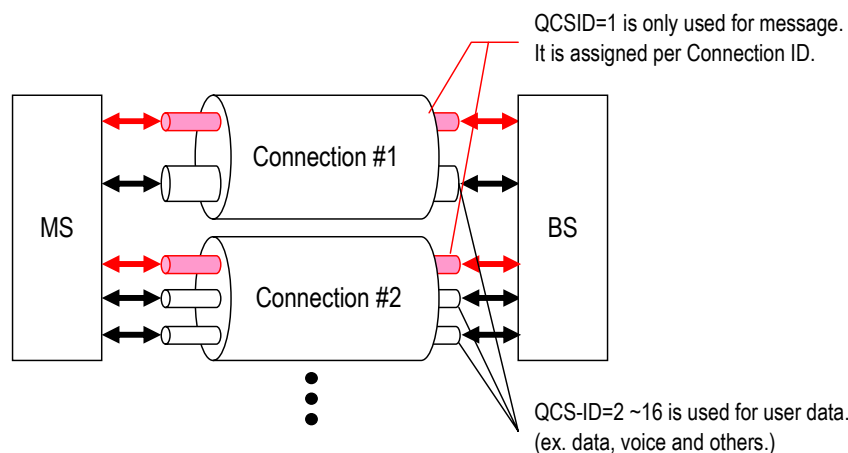

Figure 9.18 Connection and QCS

The relation between connection and QCS is shown in Figure 9.18

The value 1 of QCS-ID is used to transmit the connection and QCS control information. The value 2 to 16 of QCS-ID is used to transmit the upper layer data. The MAC control protocol is applied with all QCS-ID.

This QCS-ID assignment is applied per connection.

9.3.1 Service Class

sPHS system defines the service class as shown in Table 9.2. The service class is not defined in an individual packet but in the individual flow. The negotiation of the service class is performed according to the message when the connection is established.

These service class have a relation to QoS number. Refer to 7.3.3.17 for detail.

Table 9.2 Service Class

Service class name	Explanation
Private Line Class (PLC)	Dedicated line service is provided. A wireless bandwidth more than constancy is always secured to apply to the service with a random generation of the packet. It is guaranteed that the packet reaches the accepting station at the service rate within the decided time.
no Packet loss and Variable Rate Class (nl -VRC)	The situation in lack of the packet is not permitted and the prohibition is applied to real-time service. In order to correspond to the change in burst volume of information, it is possible to make wireless bandwidth change according to the data amount. This class guarantees the maximum delay value.
allowable Packet loss and Variable Rate Class (al-VRC)	The situation in lack of the packet is permitted, and the permission is applied to real-time service. It is possible to make wireless bandwidth change according to the data amount to correspond to the change in burst volume of information. This class guarantees the maximum delay value.
Low - Delay Best Effort Class (Ld-BE)	This class is applied to non-real-time service. It is possible to make wireless bandwidth change according to the data amount. Time delay is shorter than LAC, and the packet loss is not allowed.
Leave Alone Class (LAC)	It is applied to non-real-time service. Best effort service that does not guarantee wireless bandwidth and does not allow packet loss is supported. The maximum possible bandwidth is allocated.
Voice Class (Voice)	Dedicated line service is provided. A wireless bandwidth more than constancy is always secured to apply to the service with a random generation. The quality of bandwidth and delay time is guaranteed by TCH which is defined for voice only channel.

9.3.2 QoS Parameter

Table 9.3 shows the parameter guaranteed in each QoS service class.

Table 9.3 Service Class and Quality Parameter

	QoS parameter			Traffic parameter		
	Forwarding delay	Jitter	FER	Guarantee bandwidth	Average Bit Rate	Traffic Priority
PLC	Yes	-	Yes	Yes	Yes	Yes
nl-VRC, al-VRC	-	Yes	Yes	Yes	Yes	Yes
LD-BE	-	-	No	No	Yes	Yes
LAC	-	-	No	No	No	Yes
Voice	Yes	-	Yes	Yes	Yes	Yes

Yes : Possible to specify it.

No : Impossible to specify it.

- : Irrelevance

9.3.2.1 Forwarding Delay

The forwarding delay provided by this parameter is guaranteed in PLC of real-time service.

9.3.2.2 Jitter

It refers to difference between the maximum delay value and the minimum delay value, as well as the maximum jitter values.

9.3.2.3 Frame Error Rate (FER)

In real-time service, it provides the FER that service allows according to this parameter.

9.3.2.4 Guarantee Bandwidth

The system guarantees the bandwidth provided by this parameter.

It aims to transmit data without causing the delay when data transmission is needed by securing a necessary bandwidth without fail.

9.3.2.5 Average Bit Rate

It is a bit number of the data transmitted to a wireless section near the unit time. It provides for the

bit number of the data taken out of the made queue of each user (mean value). In Private Line Class, the average bit rate becomes the same as the guaranteed maximum bit rate because the data volume is constant.

A wireless bandwidth is prevented from being occupied when data is generated in the burst as service provide output bit rate with high priority.

9.3.2.6 Traffic Priority

This parameter is used when data in the same QoS class is given priority for process. For instance, when data requested for re-sending is made prior to usual data, the traffic priority is specified high.

9.4 Access Phase Control

9.4.1 Power Control

PC field of DL and UL PHY frame header is used for the power control. MS is able to control the UL transmission power according to the PC field data from BS (Refer to Sections 4.3.6.3 and 4.3.6.4). This power control method is mandatory, because it must be implemented for OFDMA.

BS is also able to control DL transmission power according to the PC field data from MS (Refer to Section 4.3.6.4). This power control method is optional as it is only used to decrease the interference between cells.

Figure 9.19 shows the power control diagram.

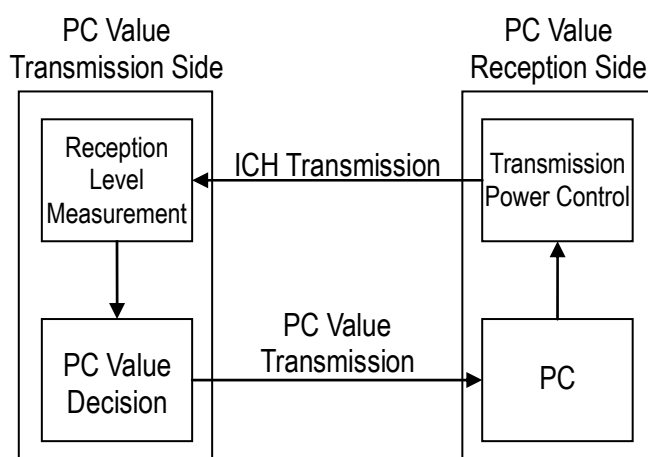

Figure 9.19 Power Control Block Diagram

The PC field transmission side sets the value to PC based on reception level of pilot symbol (Refer to Figure 9.20). This standard does not specify the timing relation between reception level and PC value.

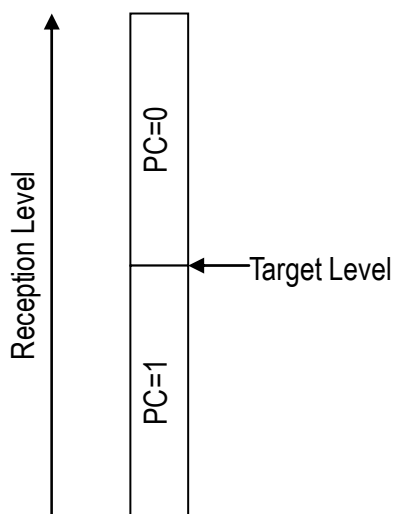

Figure 9.20 Reception Level and PC Value

The relation between the reception level and value of PC is shown below.

- Reception level > Target level
PC=0
- Reception level <= Target level
PC=1

9.4.2 Timing Control

SD field of DL PHY frame is used for the timing control. According to the SD field data from BS, MS is able to control the UL transmission timing (Refer to Section 4.3.6.2).

Figure 9.21 shows the timing control diagram. BS aligns symbol timing between MS and MS by using SD field. BS decides SD value based on reception symbol timing. MS changes transmission timing according to SD.

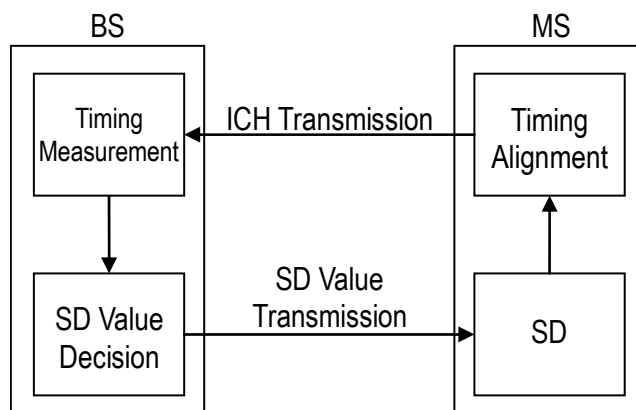

Figure 9.21 UL Timing Control Block Diagram

Figure 9.22 shows the time relationship of the reception burst and the target burst.

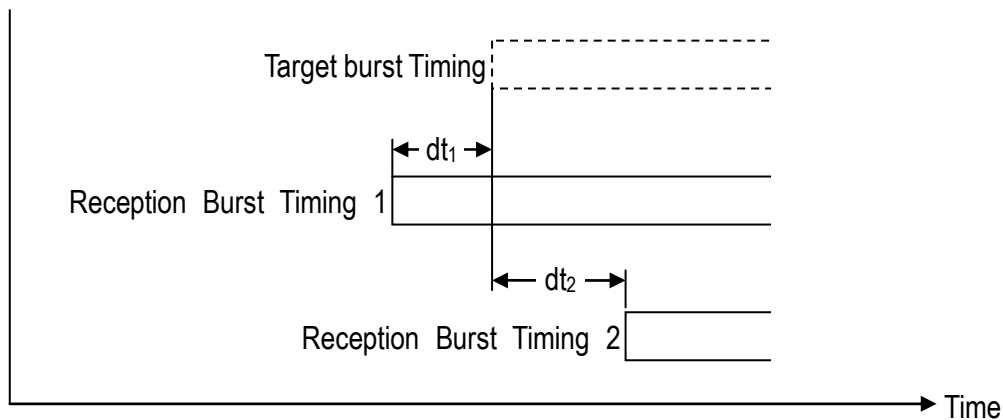

Figure 9.22 Time Difference Between Target Timing and Reception Timing

BS decides SD value as shown in Figure 9.23 when dt is defined as the difference between reception burst timing and target burst timing.

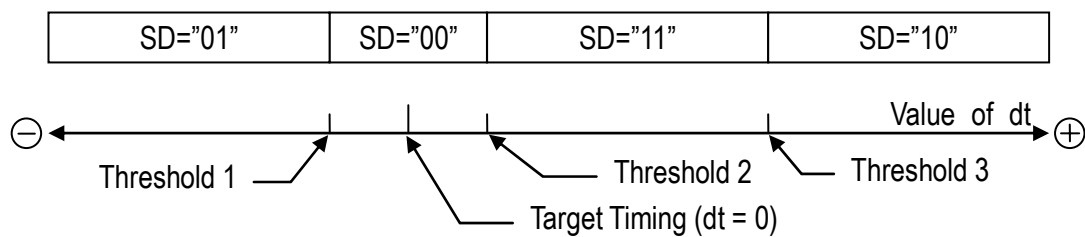

Figure 9.23 dt and SD Value

9.4.3 Link Adaptation Control

9.4.3.1 MCS Switching

9.4.3.1.1 Decision of Transmission MCS

The MCS for the data transmission in the later TDMA frame will be decided based on the MR in the received PHY header. When the MS requests one of the MCS values by using MR, the BS may use any of the MCS values that is available including those below the requested MCS value. Then the decided MCS for the DL data transmission in that TDMA frame will be set in MI field of the DL PHY header. Figure 9.24 shows the example of selecting MCS for transmission by using received MR on the PHY header.

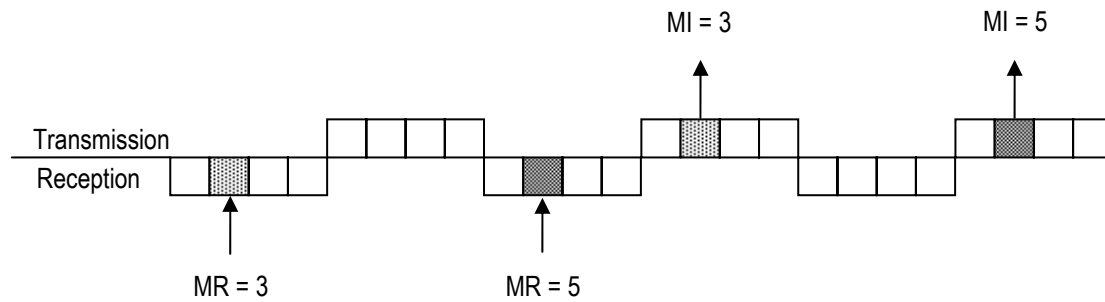

Figure 9.24 Example of MI Transmission When Switch Time Is 7.5 ms

9.4.3.1.2 Decision of The Reception of Demodulation MCS

According to the received MI, demodulation will be done in the received data of the adaptive modulation area.

9.4.3.1.3 Setup of Modulation Method in MR Field for Transmission

The average SINR for all the symbols received for the user is calculated during this process. The calculating of smoothing etc. might be applied to SINR. The modulation method to be set in the MR field will be decided from this SINR value for the time being. Figure 9.25 shows the way to set MR field based on the SINR value for the time being.

- a) When the SINR value for the time being is less than A1, BPSK (R=1/2, Efficiency=0.5) modulation method is selected for setting MR field.
- b) When the SINR value for the time being is between A1 to A2, QPSK (R=1/2, Efficiency=1) modulation method is selected for setting MR field.
- c) When the SINR value for the time being is between A2 to A3, QPSK (R=3/4, Efficiency=1.5) modulation method is selected for setting MR field.
- d) When the SINR value for the time being is between A3 to A4, 16QAM (R= 1/2, Efficiency=2) modulation method is selected for setting MR field.
- e) When the SINR value for the time being is between A4 to A5, 16QAM (R=3/4, Efficiency=3) modulation method is selected for setting MR field.
- f) When the SINR value for the time being is between A5 to A6, 64QAM (R=4/6, Efficiency=4) modulation method is selected for setting MR field.
- g) When the SINR value for the time being is between A6 to A7, 64QAM (R=5/6, Efficiency=5) modulation method is selected for setting MR field.
- h) When the SINR value for the time being is between A7 to A8, 256QAM (R=6/8, Efficiency=6) modulation method is selected for setting MR field.
- i) When the SINR value for the time being is above A8, 256QAM (R=7/8, Efficiency=7) modulation method is selected for setting MR field.

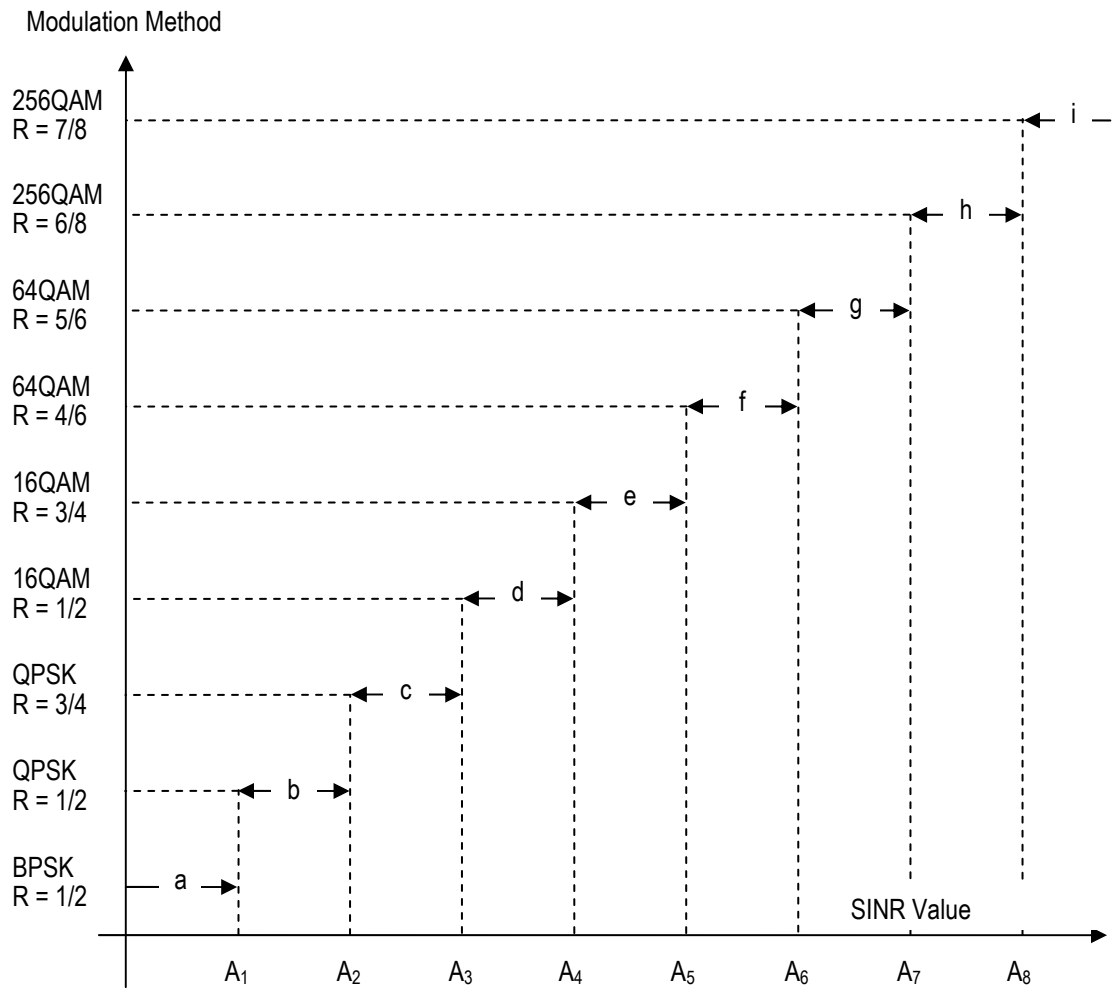

Figure 9.25 Method of Modulation Method Selection According to SINR Value

9.4.4 ANCH/CSCH Scheduling Control

Figure 9.26 shows numbering rule regarding ANCH/CSCH active frame. Both MS and BS use specified frames. It is called ANCH/CSCH active frame. Scheduling term is repeated during DL LCCH transmission period.

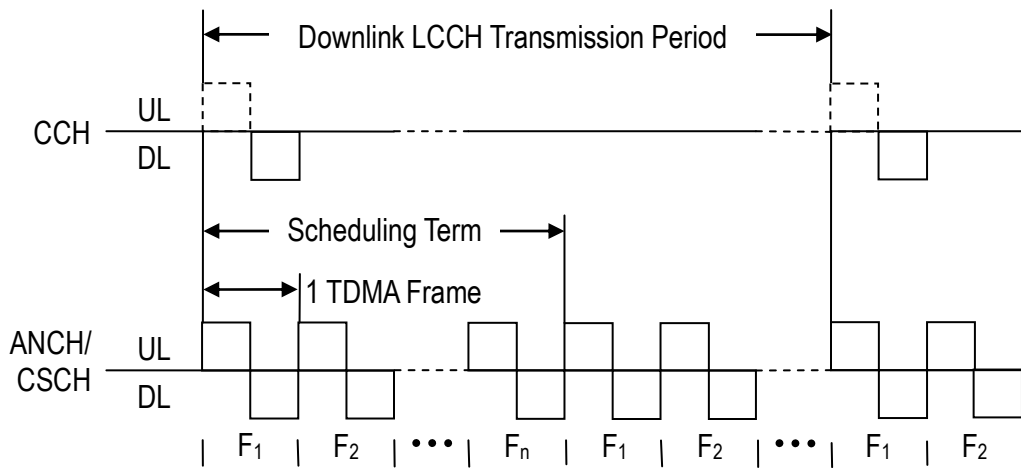

Figure 9.26 ANCH/CSCH Active Frame Number

ANCH/CSCH active frame is changed by “ANCH/CSCH switching indication” message from BS in active state. Figure 9.27 and Figure 9.28 shows the change sequence of ANCH/CSCH active frame.

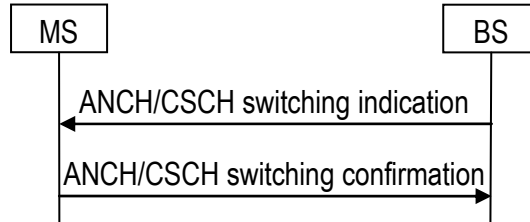

Figure 9.27 BS Origin ANCH/CSCH Scheduling Change

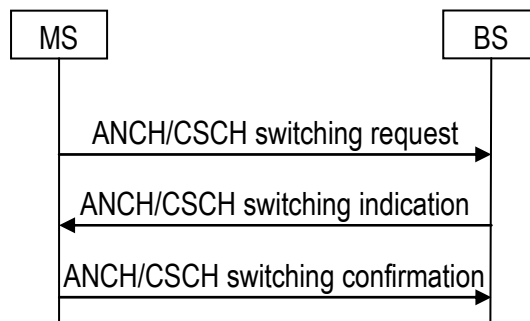

Figure 9.28 MS Origin ANCH/CSCH Scheduling Change

MS changes ANCH/CSCH active frame when MS receives ANCH/CSCH switching indication message. ANCH/CSCH switching indication message contains the following information.

- destination logical PRU number.
which is the same as the source PRU or is a different PRU
- ANCH/CSCH scheduling term
- ANCH/CSCH frame specification

MS sends ANCH/CSCH switching confirmation message after MS changes ANCH/CSCH active frame.

When MS receives indication message which has unsupported value of scheduling term, period and scheduling itself, MS can request another scheduling term, period or reject the scheduling. The rejection of scheduling can be used only when there is the necessity for the guaranteed bandwidth such as voice data.

9.4.5 Interference Avoidance Control

9.4.5.1 ANCH/CSCH Disconnect Detection

At the BS or MS, if the ANCH/CSCH reception is impossible for N successive times, the ANCH/CSCH will be released as the reception side regards the ANCH/CSCH to be disconnected. Figure 9.29 shows a sequence when ANCH/CSCH disconnection is detected at the BS side. If the N successive ANCH/CSCH disconnection does not happen, the BS will regard ANCH/CSCH to be connected. The ANCH will be released if the ANCH/CSCH is failed for the connection for N times continuously. It means transmission and reception on the ANCH/CSCH is ceased. Disconnection is detected in the same procedure at the MS. Both BS and MS regard it as an idle state after ANCH/CSCH is released.

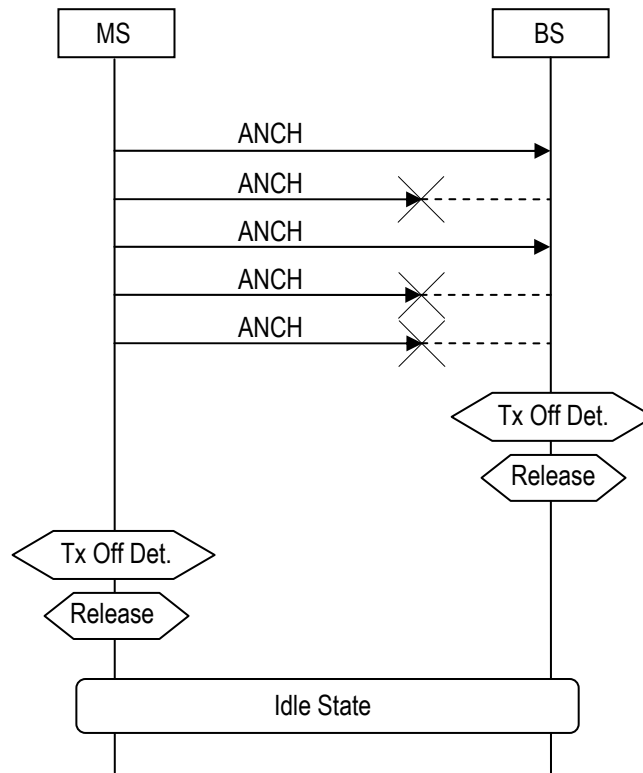

Figure 9.29 Detection of ANCH/CSCH Disconnection

9.4.5.2 ANCH/CSCH Switching

MS supervises the average SINR on the DL ANCH while BS supervises the average SINR on the UL ANCH. When the radio condition deteriorates, ANCH/CSCH will be changed to another PRU. Average SINR is calculated according to the average SINR calculation time for ANCH/CSCH. The measurement result older than the average SINR calculation time for the ANCH/CSCH is not included in the calculation average SINR.

9.4.5.2.1 MS Origin ANCH/CSCH Switching

When average SINR becomes lower than ANCH/CSCH switching DL SINR threshold, MS transmits ANCH/CSCH switching request message to BS. As soon as BS received the message, it selects the PRU from an unused PRU with CS concerned according to the channel selection algorithm. After the destination PRU was selected, BS notifies the destination PRU number by sending ANCH/CSCH switching indication message to MS. MS disconnects original PRU when it receives ANCH/CSCH switching indication message. Then DL carrier sensing for the PRU to be switched is carried out. The transmission and reception of ANCH/CSCH start if the carrier sensing result is less than DL RSSI threshold for ANCH selection (DL RSSI threshold for CSCH selection). BS judges the ANCH/CSCH switching to be success when it manages to receive UL ANCH/CSCH. BS then disconnects original ANCH/CSCH.

Figure 9.30 shows MS origin ANCH/CSCH switching sequence. The wide arrow shown in the

figure describes radio management message, and the small arrow shows radio transmission and reception.

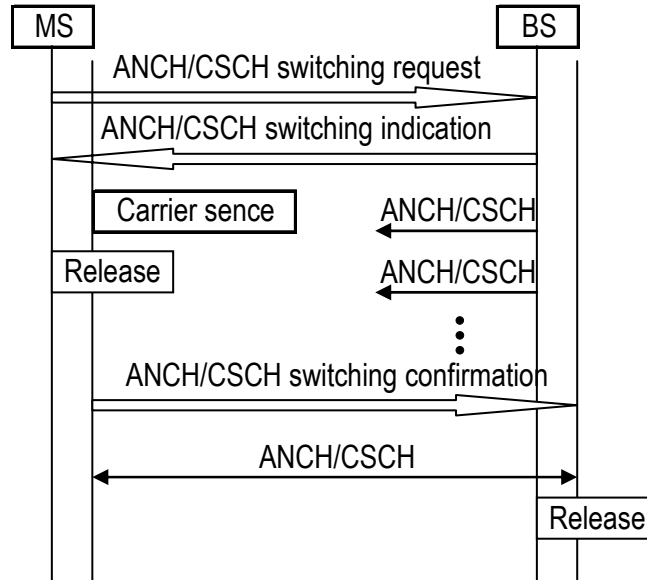

Figure 9.30 MS Origin ANCH/CSCH Switching

9.4.5.2.2 BS Origin ANCH/CSCH Switching

BS selects the destination PRU from an unused PRU with BS concerned according to the channel selection algorithm when average SINR is lower than ANCH/CSCH switching UL SINR threshold. BS then transmits radio management message "ANCH/CSCH switching indication" that contains the destination PRU number to MS. The same process will be carried out after that as MS triggered ANCH/CSCH switching.

Figure 9.31 shows BS originated ANCH/CSCH switching sequence. The wide arrow shown in the figure describes radio management message, and the small arrow shows radio transmission and reception.

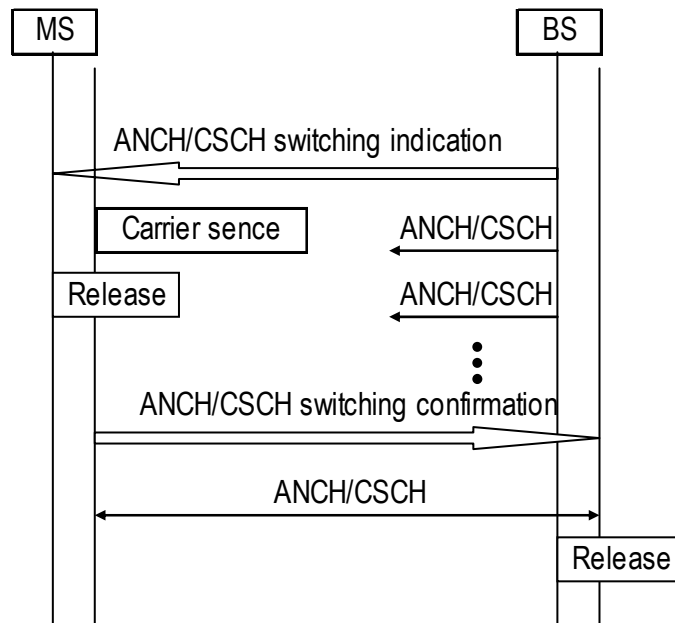

Figure 9.31 BS Origin ANCH/CSCH Switching

9.4.5.2.3 Retransmission of ANCH/CSCH Switching Indication

UL transmission for original ANCH/CSCH is only able to be detected until retransmission timer expiration when BS transmits ANCH/CSCH switching indication message, BS then judges that ANCH/CSCH switching indication message did not reach MS and it retransmits ANCH/CSCH switching indication message.

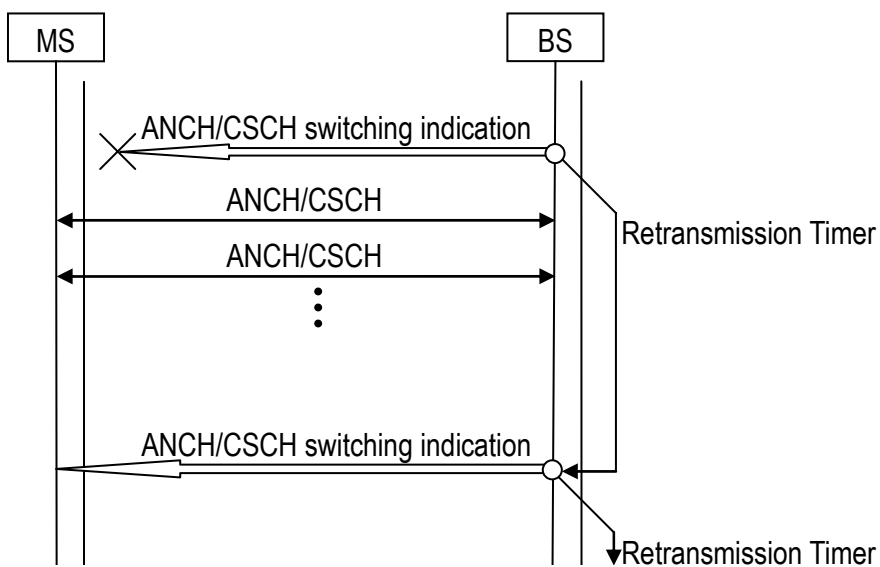

Figure 9.32 Retransmission of ANCH Switch Indication

When retrying count for ANCH/CSCH retransmission indication is over, ANCH/CSCH switching operation is finished and the original communication is continued.

9.4.5.2.4 Switchback Operation

BS continues original ANCH/CSCH transmission and reception after the transmission of ANCH/CSCH switching indication message transmission because MS carries out switch back processing in case ANCH/CSCH switching fails. When the following conditions are satisfied at MS side, the switchback operation is carried out.

- When the DL carrier sensing result at the destination PRU exceeds the DL RSSI threshold for ANCH selection (DL RSSI threshold for CSCH selection).
- When DL ANCH/CSCH is not detected at destination PRU.

Figure 9.33 shows the switch back operation. The figure describes a sequence when carrier sensing at MS side for a BS-informed PRU is OK BS tries to transmit ANCH/CSCH at destination PRU, but it cannot receive DL ANCH/CSCH, therefore switchback operation is started.

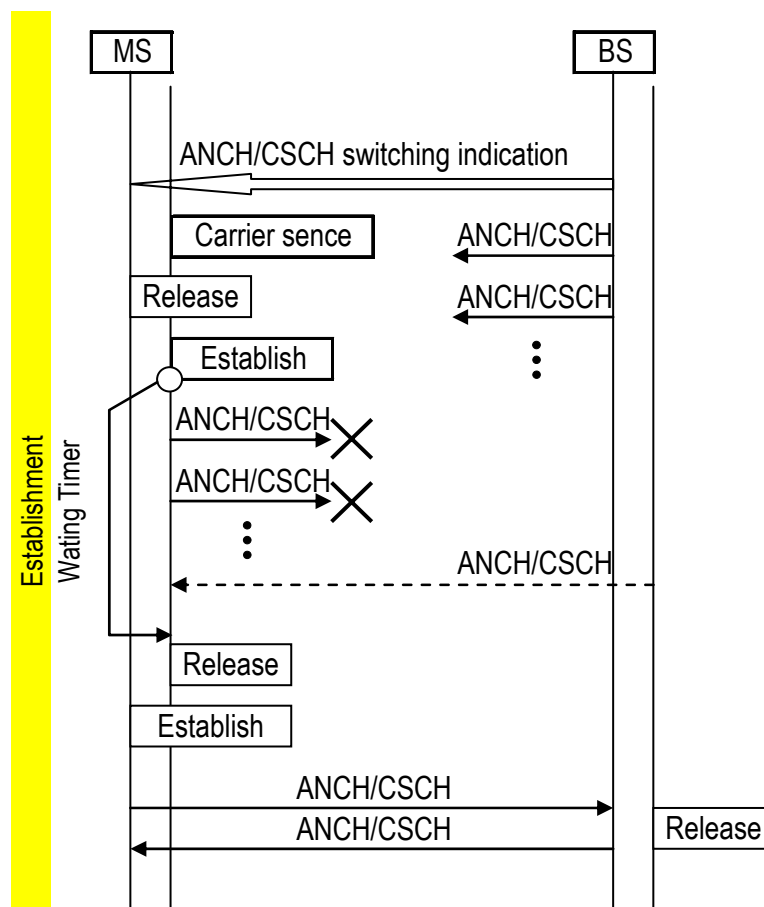

Figure 9.33 ANCH/CSCH Switchback

In the figure MS does carrier sensing at destination PRU and the result is OK. ANCH/CSCH is then established at destination PRU. Switchback operation will be started if DL ANCH/CSCH is not received at destination PRU. MS releases the destination PRU and establishes ANCH/CSCH at original PRU. BS will know that the switch of ANCH/CSCH fails if it receives UL ANCH/CSCH at original PRU. In this case, BS continues ANCH transmission and reception at original PRU.

9.4.6 Handover Control

There are two kinds of handover procedure definition for sPHS.

One is normal handover, of which the processing is started after all the radio connections with BS are disconnected.

The other is seamless handover, of which the processing is started with no need to disconnect the BS in connection. Seamless handover can be carried out with less overhead.

- When MS is handed over to BS, connection establishment procedure is conducted in the same way. MS transmits LCH assignment request message to BS-B which is selected by

MS according to each procedure. After MS receives LCH assignment message from BS-B, MS carries out transmission by changing radio state from idle to active and connecting ANCH/CSCH. After connection is established to BS-B, resource release operation is carried out from network side of BS-A.

BS-A : The BS from which the MS is handed over.

BS-B : The BS to which the MS is being handed over.

9.4.6.1 Normal Handover

MS starts connection establishment processing after stopping CCH capture and ICH transmission/reception. The conditions to start normal handover are describes as follows.

- When DL ANCH/CSCH disconnection is detected at less RSSI value for DL ANCH/CSCH than the threshold of handover processing level.
- When the RSSI value of UL ANCH/CSCH is less than threshold of handover processing level.
- When BS cannot assign PRU to be switched although ANCH/CSCH switching condition is satisfied.

“ANCH/CSCH switching indication” message is transmitted from BS to MS in case when BS starts normal handover. MS starts normal handover when it receives the message. Once of MS starts normal handover, it will not transmit any signal to BS to inform the start of handover processing.

MS starts the search for destination BS after transmission stops. The result of the search for destination BS is arranged in order of RSSI value from the highest one on. When the handover process starts, destination BS is chosen from the list which is created as a result of the search for destination BS. The BS which has indicated the highest RSSI value should be given the highest priority over all others for destination BS choice.

9.4.6.2 Seamless Handover

MS searches for destination BS while maintaining the connection to the original BS. Destination BS is chosen from information based on search result. The conditions to start seamless handover are as follows:

- when SINR of DL ANCH/CSCH becomes less than seamless handover SINR threshold.
- when SINR of UL ANCH/CSCH becomes less than seamless handover processing SINR.

When the condition to start MS originated seamless handover is satisfied, LCH assignment request message will be transmitted from the MS to destination BS if MS has available destination BS list.

If MS does not have available destination BS list, MS transmits ANCH/CSCH switching request [No destination BS list] message to the original BS to search for destination BS. When BS receives ANCH/CSCH switching request [No destination BS list], it allocates all EXCHs to the MS. If there is no EXCH allocation for the MS, the MS starts destination BS search processing at all

TDMA slots except for the TDMA slot which ANCH/CSCH is allocated. In this case, The BS searching process is carried out to all relative slots except for the TDMA slot to which ANCH/CSCH is allocated. After the searching process for destination BS is completed, LCH assignment request message is transmitted to the destination BS.

When MS receives LCH assignment reject message from destination BS, MS re-select destination BS from its own destination BS list, then seamless handover process is carried out again.

When MS receives LCH assignment message from destination BS, ANCH/CSCH transmission and reception starts at destination BS without disconnecting radio link. When radio resource allocation is received from destination BS through MAP in DL ANCH/CSCH, radio link between original BS is disconnected.

9.5 MAC Layer Control

9.5.1 Window Control

In sPHS, window control is carried out. Delivery confirmation is done by the RR message. Window position is updated according to the sequence number contained in the RR message. Data transmission stops when the transmission data reaches the window size. Figure 9.34 shows the example of the window size equal to 4. In the figure, the arrow stands for the available area to transmit the data. The number in the figure is the sequence number. The circle that is shown in the left side of the figure shows the case that a RR message is received when the sequence number N contained in the RR message is 2. In this case, the data in the window can be transmitted when N is a number between 2 and 5. The circle shown in the right side of the figure shows the case that a RR message is received with N as 4. In this case, the data in the window can be transmitted when N is a number between 4 and 7.

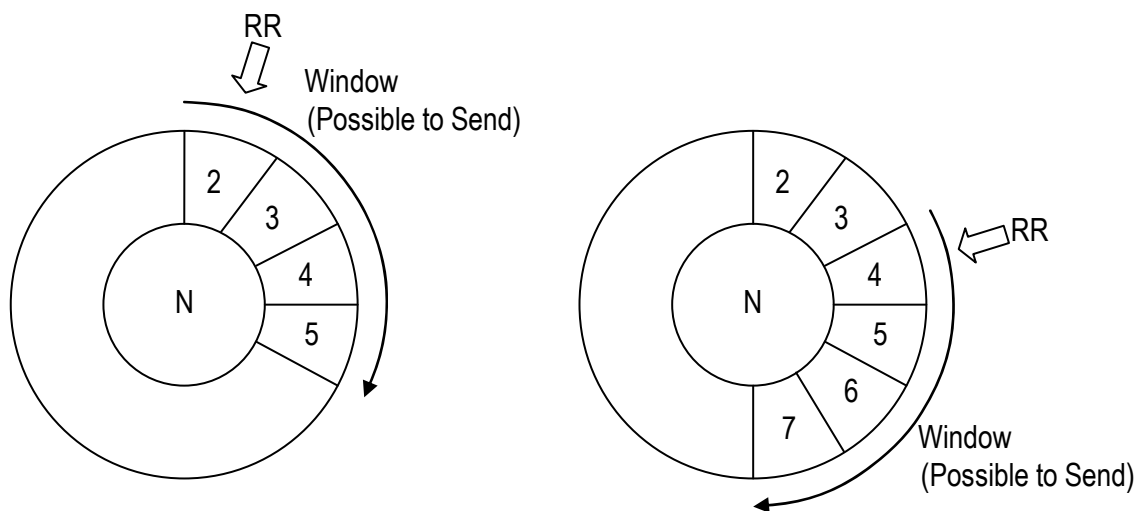

Figure 9.34 Window Control

Window size is defined by negotiation between MS and BS when the connection is established. Though the name of element for negotiation is window size, window size itself is a parameter and each window size parameter is related with the transmitting acknowledge timing and maximum receiving unit without receiving acknowledge.

Figure 9.35 shows the example of the window control sequence when the window size is 4. In the figure, MS transmits the data until the end of the window size when becomes 5 after MS receives RR with N as 2. Since the transmission data reaches the window size, data transmission is suspended until the delivery confirmation is received. When MS receives the RR with N as 4, the window position is updated. Then the data transmission is resumed.

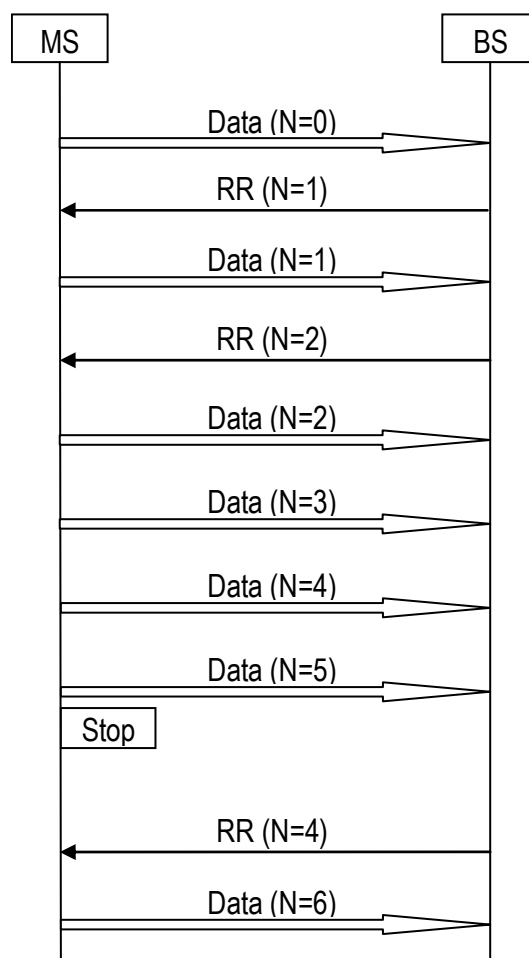

Figure 9.35 Window Control Sequence

9.5.2 Flow Control

Flow control in the radio section is carried out by the notification of busy status using RNR message of the MAC control protocol and window control which is described in Section 9.5.1. Figure 9.36 shows an example of flow control using the RNR message. In the figure, busy state occurs in MS when MS receives data with sequence number N as 1. MS then sends RNR message with N as 2 in order to suspend data transmission from BS. MS sends RR message with N as 2 afterwards to notify BS to resume data transmission when it recovers from the busy state. BS then resumes data transmission.

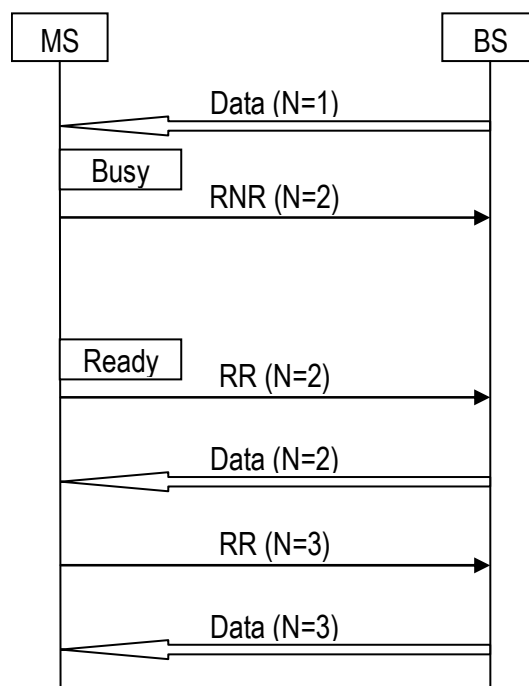

Figure 9.36 RNR Used in Flow Control

RNR message may not reach to the opposite side in case of bad radio condition. Figure 9.37 shows an example that MS has transmitted RNR to BS, while RNR fails to reach BS. The figure shows the case of window size as 4. BS continues to transmit DL data within its window size to MS. The sender BS suspends data transmission when the DL data transmission reached the window boundary. Even though the RNR does not reach BS, data transmission can be suspended as if busy state occurs on the reception side.

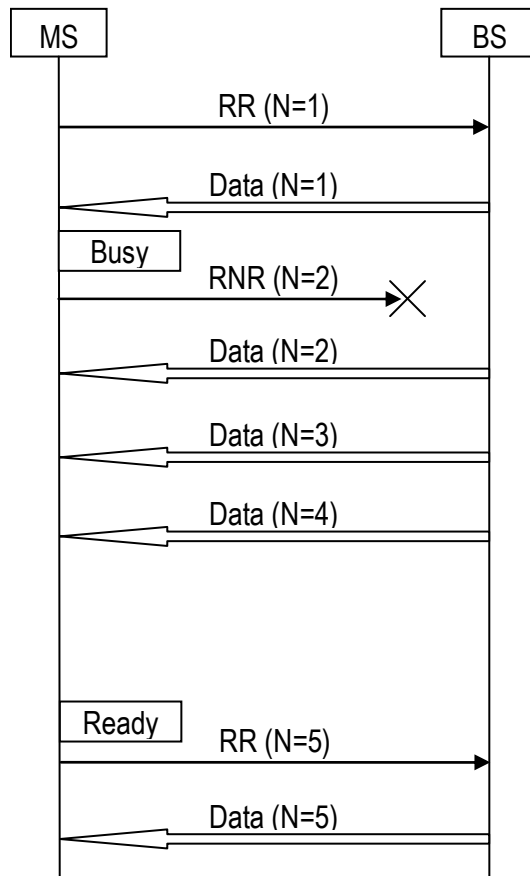

Figure 9.37 Failure of RNR reception

9.5.3 Retransmission Control by SR Method

Reception side sends SREJ message with designation sequence number when it requests retransmission of a certain data. Transmission side retransmits specified data on receiving this SREJ message.

The reception side may transmit REJ message instead of SREJ when there are many data to be retransmitted. Transmission side resumes transmission from the data specified by sequence number on receiving this REJ message.

The transmission side should hold the transmitted data until corresponding received confirmation message (RR/RNR) is received.

Figure 9.38 shows example of SREJ operation.

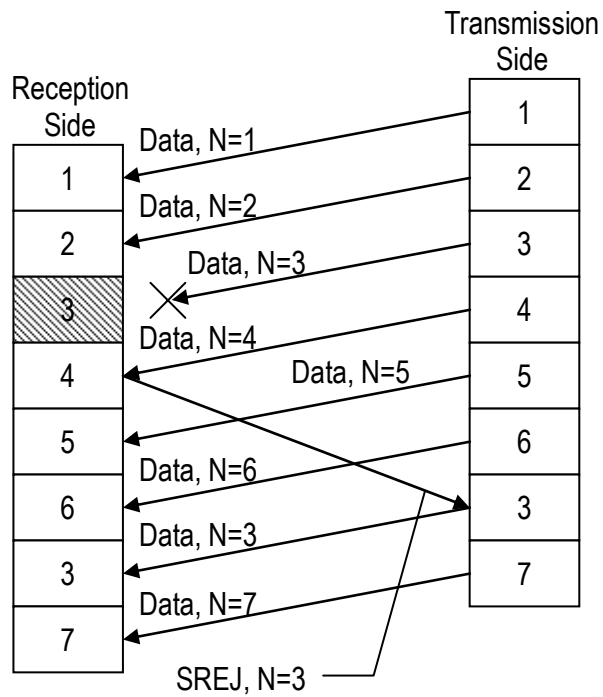

Figure 9.38 Sequence of SREJ

Reception side should start SREJ retransmission timer when MAC sends SREJ message. The timer should be stopped when the timer is expired. SREJ is transmitted again when the timer is expired. But, FRMR will be transmitted and the ARQ operation will be cancelled if the SREJ retransmission count exceeds the limitation.

Figure 9.39 shows an example of SREJ retry operation.

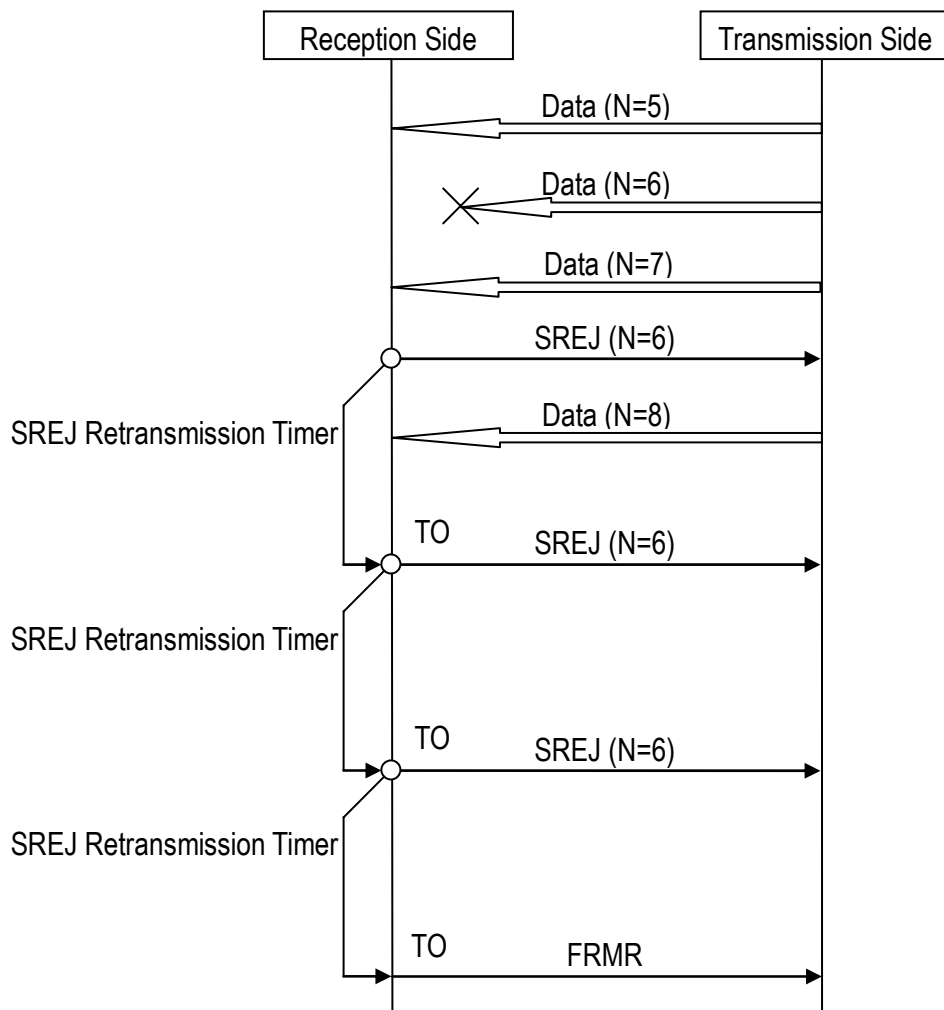

Figure 9.39 MAC-ARQ SREJ Retry Operation

RR should be sent if reception side receives retransmitted data.
 Figure 9.40 shows an example of MAC-ARQ operation.

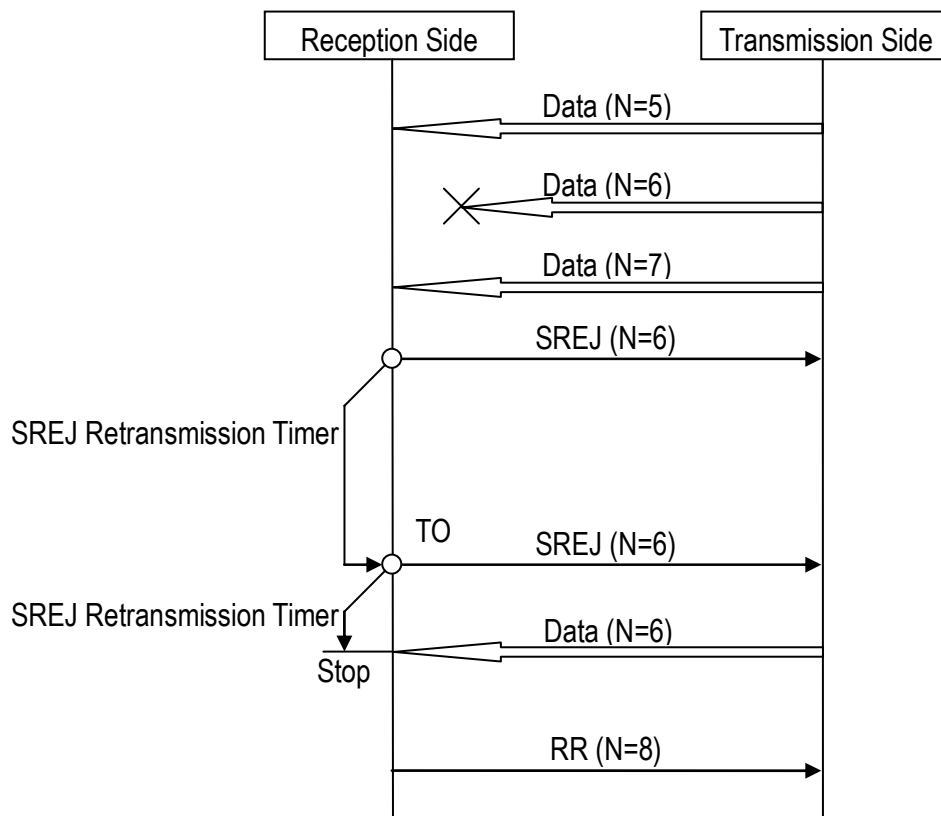

Figure 9.40 ARQ Succession

9.5.4 Notification and Recovery of Error Condition

When abnormal situation occurs, restoration process will be carried out by transmitting FRMR message.

FRMR message will be transmitted in following cases.

- Sequence Number Error
A frame which has unexpected sequence number is detected.
- Invalid Frame Reception
When the MAC frame length does not meet for the regulation specified.
- Abnormal Frame Reception
When MAC frame with header not specified in this specification is detected.
- Over the retransmission times
This error is detected when the number of retransmission times exceeds the limit or when the number of timer restart exceeds the limit.
- Other Error
This error is detected when undefined error occurred.

Transmission is re-started when new data come from upper layer.

9.6 Encryption Field

Encryption is applied only to MAC payload. Encryption management is done before the CRC addition.

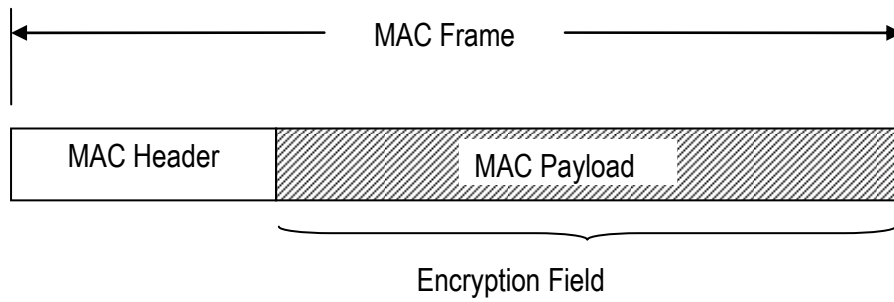

Figure 9.41 Encryption Field

Appendix A: Full Subcarrier Mode

A.1 Overview

Full subcarrier mode defines the way to allocate DC carrier and guard carrier for the purpose of improving data throughput. Note that full subcarrier mode is used only in DL.

A.2 Definition of Full Subcarrier Mode

Figure A.1 shows full subcarrier mode in several ECBWs as examples. As shown in the figure, all subcarriers in ECBW except central subcarrier shall be used as data subcarriers.

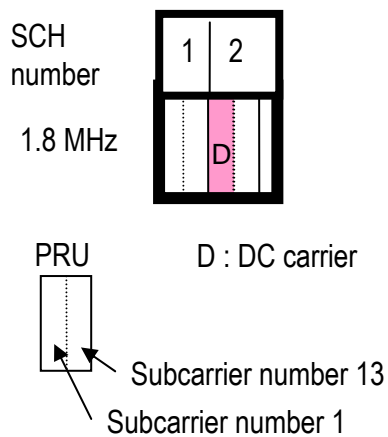
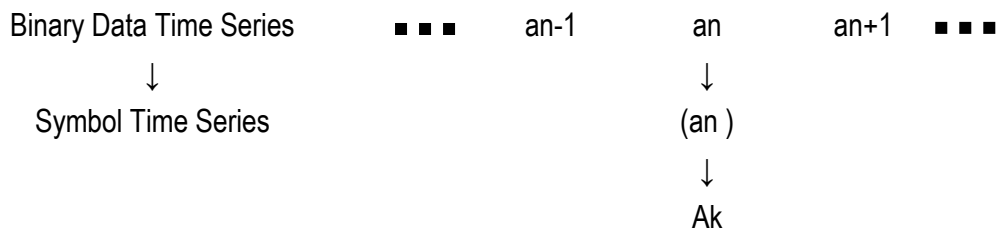

Figure A.1 Full Subcarrier Mode

Appendix B: Modulation

B.1 BPSK

(1) The serial signal input is converted to (A_k) symbols by the serial/parallel converter and then changed to corresponding signals (I_k, Q_k) by the encoder. Conversion from serial signal input to (A_k) (binary/binary conversion) is performed as noted below, and conversion from (A_k) to (I_k, Q_k) is performed according to the table below.



A_k	I_k	Q_k
1	1	0
0	-1	0

(2) The signal space diagram is shown in figure below.

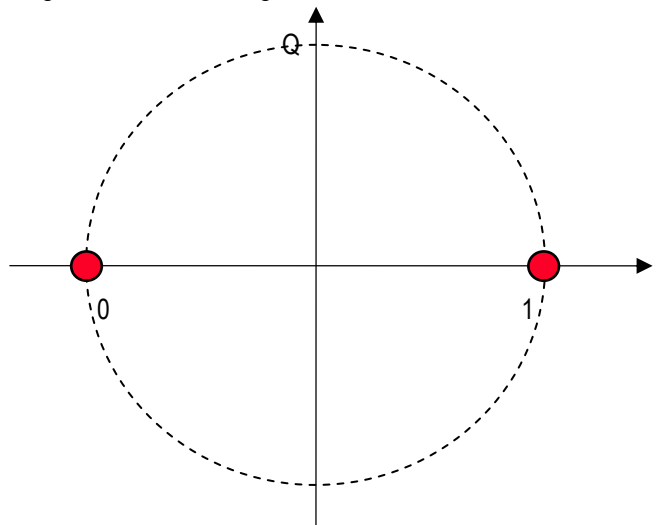
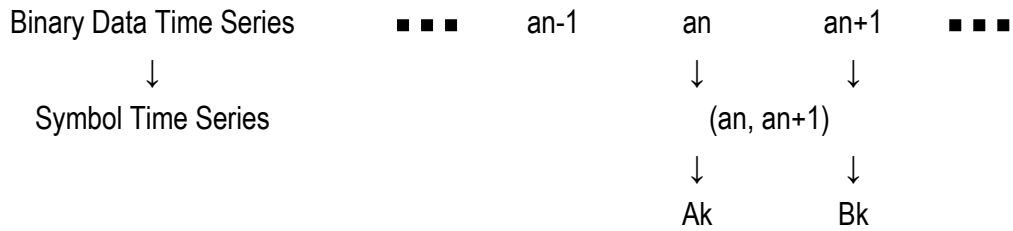

Figure B.1 BPSK

B.3 QPSK

(1) The serial signal input is converted to (A_k, B_k) symbols by the serial/parallel converter and then changed to corresponding signals (I_k, Q_k) by the encoder. Conversion from serial signal input to (A_k, B_k) (binary/quaternary conversion) is performed as noted below, and conversion from (A_k, B_k) to (I_k, Q_k) is performed according to the table below.



A_k	B_k	I_k	Q_k
1	1	$1/\sqrt{2}$	$1/\sqrt{2}$
1	0	$1/\sqrt{2}$	$-1/\sqrt{2}$
0	1	$-1/\sqrt{2}$	$1/\sqrt{2}$
0	0	$-1/\sqrt{2}$	$-1/\sqrt{2}$

(2) The signal space diagram is shown in the figure below.

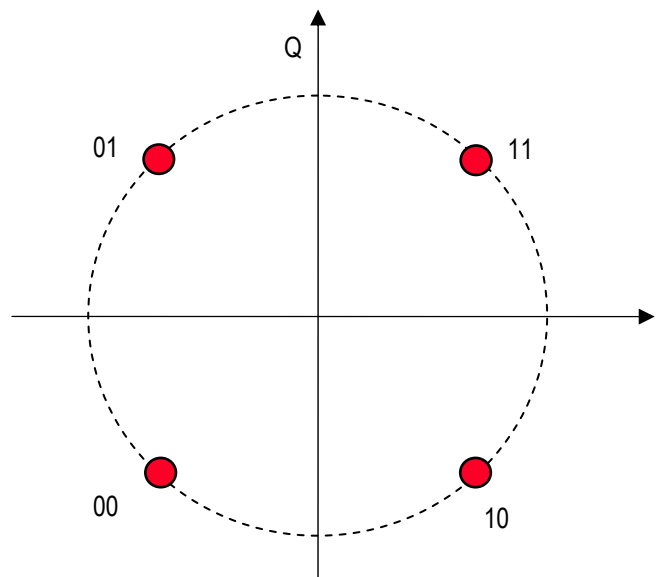

Figure B.3 QPSK

B.4 $\pi/4$ - QPSK

(1) The serial signal input is converted to (A_{2k}, B_{2k}) or (A_{2k+1}, B_{2k+1}) symbols by the serial/parallel converter and then changed to corresponding signals (I_{2k}, Q_{2k}) or (I_{2k+1}, Q_{2k+1}) by the encoder. Conversion from serial signal input to (A_{2k}, B_{2k}) or (A_{2k+1}, B_{2k+1}) (binary/quaternary conversion) is performed as noted below, and conversion from (A_{2k}, B_{2k}) to (I_{2k}, Q_{2k}) or conversion from (A_{2k+1}, B_{2k+1}) to (I_{2k+1}, Q_{2k+1}) is performed according to the table below.

Binary Data Time Series	■■■	a_{4n-1}	a_{4n}	a_{4n+1}	a_{4n+2}	a_{4n+3}	■■■
↓			↓	↓	↓	↓	
Symbol Time Series			(a_{4n}, a_{4n+1})		(a_{4n+2}, a_{4n+3})		
			↓	↓	↓	↓	
			A_{2k}	B_{2k}	A_{2k+1}	B_{2k+1}	

A_{2k}	B_{2k}	I_k	Q_k	A_{2k+1}	B_{2k+1}	I_k	Q_k
1	1	$1/\sqrt{2}$	$1/\sqrt{2}$	1	1	1	0
1	0	$1/\sqrt{2}$	$-1/\sqrt{2}$	1	0	0	-1
0	1	$-1/\sqrt{2}$	$1/\sqrt{2}$	0	1	0	1
0	0	$-1/\sqrt{2}$	$-1/\sqrt{2}$	0	0	-1	0

(2) The signal space diagram is shown in the figure below.

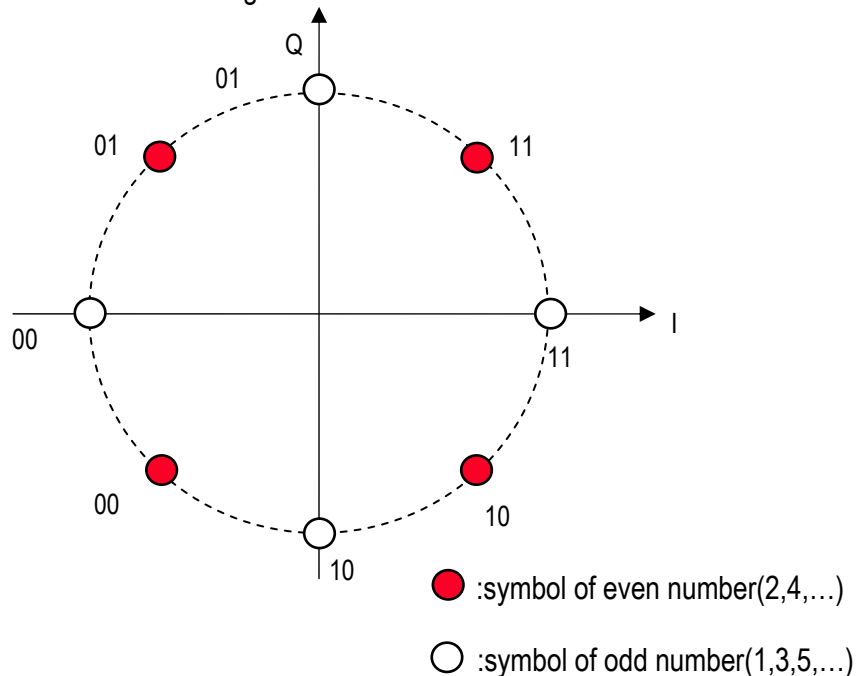

Figure B.4 $\pi/4$ - QPSK

(2) The signal space diagram is shown in figure below.

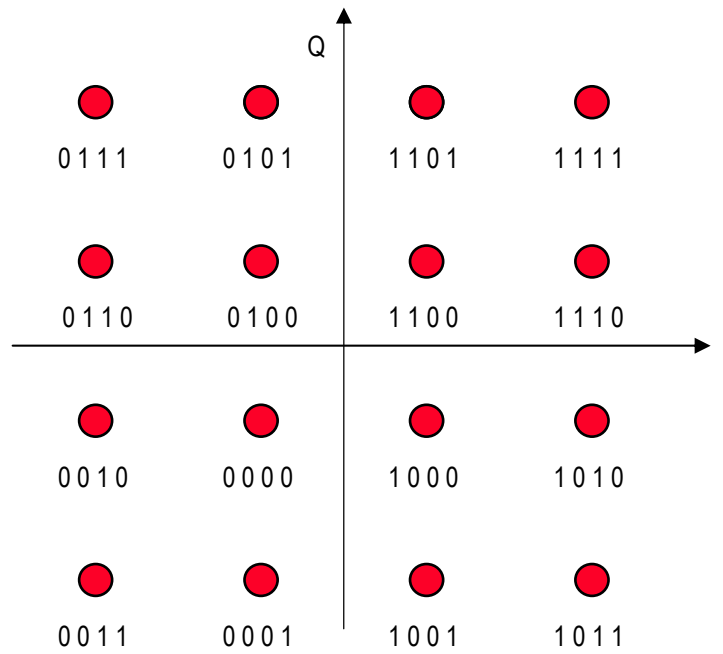

Figure B.6 16QAM

1	0	0	0	0	1	$3/\sqrt{42}$	$-1/\sqrt{42}$
1	0	0	0	0	0	$3/\sqrt{42}$	$-3/\sqrt{42}$
1	0	0	1	0	0	$3/\sqrt{42}$	$-5/\sqrt{42}$
1	0	0	1	0	1	$3/\sqrt{42}$	$-7/\sqrt{42}$
1	1	0	1	1	1	$1/\sqrt{42}$	$7/\sqrt{42}$
1	1	0	1	1	0	$1/\sqrt{42}$	$5/\sqrt{42}$
1	1	0	0	1	0	$1/\sqrt{42}$	$3/\sqrt{42}$
1	1	0	0	1	1	$1/\sqrt{42}$	$1/\sqrt{42}$
1	0	0	0	1	1	$1/\sqrt{42}$	$-1/\sqrt{42}$
1	0	0	0	1	0	$1/\sqrt{42}$	$-3/\sqrt{42}$
1	0	0	1	1	0	$1/\sqrt{42}$	$-5/\sqrt{42}$
1	0	0	1	1	1	$1/\sqrt{42}$	$-7/\sqrt{42}$
0	1	0	1	1	1	$-1/\sqrt{42}$	$7/\sqrt{42}$
0	1	0	1	1	0	$-1/\sqrt{42}$	$5/\sqrt{42}$
0	1	0	0	1	0	$-1/\sqrt{42}$	$3/\sqrt{42}$
0	1	0	0	1	1	$-1/\sqrt{42}$	$1/\sqrt{42}$
0	0	0	0	1	1	$-1/\sqrt{42}$	$-1/\sqrt{42}$
0	0	0	0	1	0	$-1/\sqrt{42}$	$-3/\sqrt{42}$
0	0	0	1	1	0	$-1/\sqrt{42}$	$-5/\sqrt{42}$
0	0	0	1	1	1	$-1/\sqrt{42}$	$-7/\sqrt{42}$
0	1	0	1	0	1	$-3/\sqrt{42}$	$7/\sqrt{42}$
0	1	0	1	0	0	$-3/\sqrt{42}$	$5/\sqrt{42}$
0	1	0	0	0	0	$-3/\sqrt{42}$	$3/\sqrt{42}$
0	1	0	0	0	1	$-3/\sqrt{42}$	$1/\sqrt{42}$
0	0	0	0	0	1	$-3/\sqrt{42}$	$-1/\sqrt{42}$
0	0	0	0	0	0	$-3/\sqrt{42}$	$-3/\sqrt{42}$
0	0	0	1	0	0	$-3/\sqrt{42}$	$-5/\sqrt{42}$
0	0	0	1	0	1	$-3/\sqrt{42}$	$-7/\sqrt{42}$
0	1	1	1	0	1	$-5/\sqrt{42}$	$7/\sqrt{42}$
0	1	1	1	0	0	$-5/\sqrt{42}$	$5/\sqrt{42}$
0	1	1	0	0	0	$-5/\sqrt{42}$	$3/\sqrt{42}$
0	1	1	0	0	1	$-5/\sqrt{42}$	$1/\sqrt{42}$
0	0	1	0	0	1	$-5/\sqrt{42}$	$-1/\sqrt{42}$
0	0	1	0	0	0	$-5/\sqrt{42}$	$-3/\sqrt{42}$
0	0	1	1	0	0	$-5/\sqrt{42}$	$-5/\sqrt{42}$
0	0	1	1	0	1	$-5/\sqrt{42}$	$-7/\sqrt{42}$

0	1	1	1	1	1		$-7/\sqrt{42}$	$7/\sqrt{42}$
0	1	1	1	1	0		$-7/\sqrt{42}$	$5/\sqrt{42}$
0	1	1	0	1	0		$-7/\sqrt{42}$	$3/\sqrt{42}$
0	1	1	0	1	1		$-7/\sqrt{42}$	$1/\sqrt{42}$
0	0	1	0	1	1		$-7/\sqrt{42}$	$-1/\sqrt{42}$
0	0	1	0	1	0		$-7/\sqrt{42}$	$-3/\sqrt{42}$
0	0	1	1	1	0		$-7/\sqrt{42}$	$-5/\sqrt{42}$
0	0	1	1	1	1		$-7/\sqrt{42}$	$-7/\sqrt{42}$

(2) The signal space diagram is shown in the figure below.

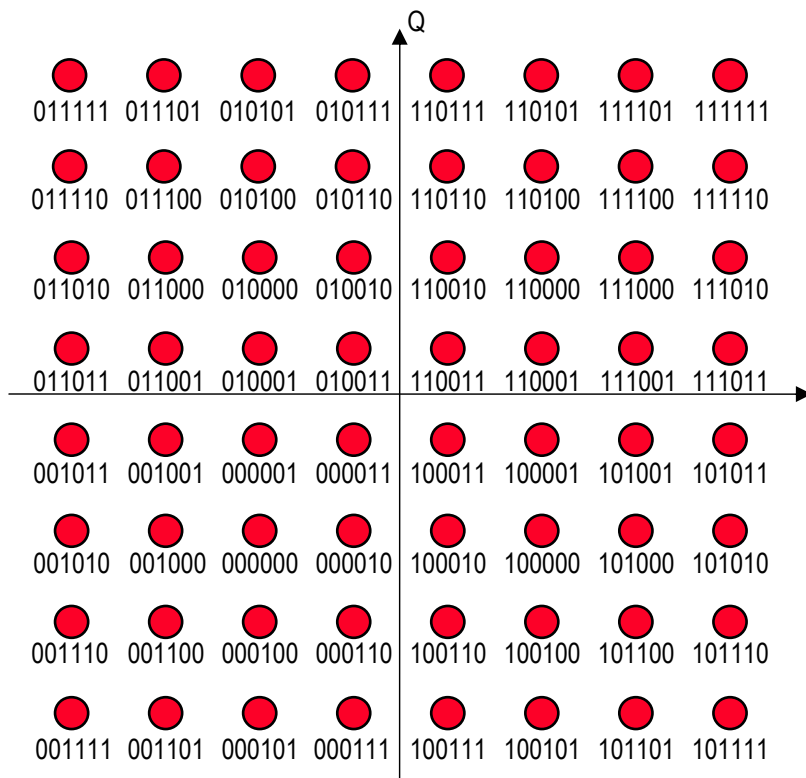
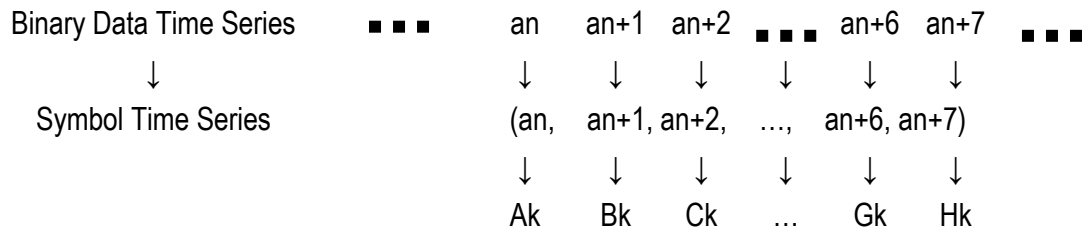

Figure B.7 64QAM

B.8 256QAM

(1) The serial signal input is converted to $(A_k, B_k, C_k, D_k, E_k, F_k, G_k, H_k)$ symbols by the serial/parallel converter and then changed to corresponding signals (I_k, Q_k) by the encoder. Conversion from serial signal input to $(A_k, B_k, C_k, D_k, E_k, F_k, G_k, H_k)$ (binary/256ary conversion) is performed as noted below, and conversion from $(A_k, B_k, C_k, D_k, E_k, F_k, G_k, H_k)$ to (I_k, Q_k) is performed according to the table below.



Ak	Bk	Ck	Dk	Ek	Fk	Gk	Hk	Ik	Qk	Ak	Bk	Ck	Dk	Ek	Fk	Gk	Hk	Ik	Qk
0	0	0	0	0	0	0	0	-5/√170	-5/√170	0	0	1	0	0	0	0	0	-11/√170	-5/√170
0	0	0	0	0	0	0	1	-5/√170	-7/√170	0	0	1	0	0	0	0	1	-11/√170	-7/√170
0	0	0	0	0	0	1	0	-7/√170	-5/√170	0	0	1	0	0	0	1	0	-9/√170	-5/√170
0	0	0	0	0	0	1	1	-7/√170	-7/√170	0	0	1	0	0	0	1	1	-9/√170	-7/√170
0	0	0	0	0	1	0	0	-5/√170	-3/√170	0	0	1	0	0	1	0	0	-11/√170	-3/√170
0	0	0	0	0	1	0	1	-5/√170	-1/√170	0	0	1	0	0	1	0	1	-11/√170	-1/√170
0	0	0	0	0	1	1	0	-7/√170	-3/√170	0	0	1	0	0	1	1	0	-9/√170	-3/√170
0	0	0	0	0	1	1	1	-7/√170	-1/√170	0	0	1	0	0	1	1	1	-9/√170	-1/√170
0	0	0	0	1	0	0	0	-3/√170	-5/√170	0	0	1	0	1	0	0	0	-13/√170	-5/√170
0	0	0	0	1	0	0	1	-3/√170	-7/√170	0	0	1	0	1	0	0	1	-13/√170	-7/√170
0	0	0	0	1	0	1	0	-1/√170	-5/√170	0	0	1	0	1	0	1	0	-15/√170	-5/√170
0	0	0	0	1	0	1	1	-1/√170	-7/√170	0	0	1	0	1	0	1	1	-15/√170	-7/√170
0	0	0	0	1	1	0	0	-3/√170	-3/√170	0	0	1	0	1	1	0	0	-13/√170	-3/√170
0	0	0	0	1	1	0	1	-3/√170	-1/√170	0	0	1	0	1	1	0	1	-13/√170	-1/√170
0	0	0	0	1	1	1	0	-1/√170	-3/√170	0	0	1	0	1	1	1	0	-15/√170	-3/√170
0	0	0	0	1	1	1	1	-1/√170	-1/√170	0	0	1	0	1	1	1	1	-15/√170	-1/√170
0	0	0	1	0	0	0	0	-5/√170	-11/√170	0	0	1	1	0	0	0	0	-11/√170	-11/√170
0	0	0	1	0	0	0	1	-5/√170	-9/√170	0	0	1	1	0	0	0	1	-11/√170	-9/√170
0	0	0	1	0	0	1	0	-7/√170	-11/√170	0	0	1	1	0	0	1	0	-9/√170	-11/√170
0	0	0	1	0	0	1	1	-7/√170	-9/√170	0	0	1	1	0	0	1	1	-9/√170	-9/√170
0	0	0	1	0	1	0	0	-5/√170	-13/√170	0	0	1	1	0	1	0	0	-11/√170	-13/√170
0	0	0	1	0	1	0	1	-5/√170	-15/√170	0	0	1	1	0	1	0	1	-11/√170	-15/√170
0	0	0	1	0	1	1	0	-7/√170	-13/√170	0	0	1	1	0	1	1	0	-9/√170	-13/√170
0	0	0	1	0	1	1	1	-7/√170	-15/√170	0	0	1	1	0	1	1	1	-9/√170	-15/√170
0	0	0	1	1	0	0	0	-3/√170	-11/√170	0	0	1	1	1	0	0	0	-13/√170	-11/√170
0	0	0	1	1	0	0	1	-3/√170	-9/√170	0	0	1	1	1	0	0	1	-13/√170	-9/√170
0	0	0	1	1	0	1	0	-1/√170	-11/√170	0	0	1	1	1	0	1	0	-15/√170	-11/√170
0	0	0	1	1	0	1	1	-1/√170	-9/√170	0	0	1	1	1	0	1	1	-15/√170	-9/√170
0	0	0	1	1	1	0	0	-3/√170	-13/√170	0	0	1	1	1	1	0	0	-13/√170	-13/√170
0	0	0	1	1	1	0	1	-3/√170	-15/√170	0	0	1	1	1	1	0	1	-13/√170	-15/√170
0	0	0	1	1	1	1	0	-1/√170	-13/√170	0	0	1	1	1	1	1	0	-15/√170	-13/√170
0	0	0	1	1	1	1	1	-1/√170	-15/√170	0	0	1	1	1	1	1	1	-15/√170	-15/√170

Ak	Bk	Ck	Dk	Ek	Fk	Gk	Hk	Ik	Qk	Ak	Bk	Ck	Dk	Ek	Fk	Gk	Hk	Ik	Qk
0	1	0	0	0	0	0	0	-5/√170	5/√170	0	1	1	0	0	0	0	0	-11/√170	5/√170
0	1	0	0	0	0	0	1	-5/√170	7/√170	0	1	1	0	0	0	0	1	-11/√170	7/√170
0	1	0	0	0	0	1	0	-7/√170	5/√170	0	1	1	0	0	0	1	0	-9/√170	5/√170
0	1	0	0	0	0	1	1	-7/√170	7/√170	0	1	1	0	0	0	1	1	-9/√170	7/√170
0	1	0	0	0	1	0	0	-5/√170	3/√170	0	1	1	0	0	1	0	0	-11/√170	3/√170
0	1	0	0	0	1	0	1	-5/√170	1/√170	0	1	1	0	0	1	0	1	-11/√170	1/√170
0	1	0	0	0	1	1	0	-7/√170	3/√170	0	1	1	0	0	1	1	0	-9/√170	3/√170
0	1	0	0	0	1	1	1	-7/√170	1/√170	0	1	1	0	0	1	1	1	-9/√170	1/√170
0	1	0	0	1	0	0	0	-3/√170	5/√170	0	1	1	0	1	0	0	0	-13/√170	5/√170
0	1	0	0	1	0	0	1	-3/√170	7/√170	0	1	1	0	1	0	0	1	-13/√170	7/√170
0	1	0	0	1	0	1	0	-1/√170	5/√170	0	1	1	0	1	0	1	0	-15/√170	5/√170
0	1	0	0	1	0	1	1	-1/√170	7/√170	0	1	1	0	1	0	1	1	-15/√170	7/√170
0	1	0	0	1	1	0	0	-3/√170	3/√170	0	1	1	0	1	1	0	0	-13/√170	3/√170
0	1	0	0	1	1	0	1	-3/√170	1/√170	0	1	1	0	1	1	0	1	-13/√170	1/√170
0	1	0	0	1	1	1	0	-1/√170	3/√170	0	1	1	0	1	1	1	0	-15/√170	3/√170
0	1	0	0	1	1	1	1	-1/√170	1/√170	0	1	1	0	1	1	1	1	-15/√170	1/√170
0	1	0	1	0	0	0	0	-5/√170	11/√170	0	1	1	1	0	0	0	0	-11/√170	11/√170
0	1	0	1	0	0	0	1	-5/√170	9/√170	0	1	1	1	0	0	0	1	-11/√170	9/√170
0	1	0	1	0	0	1	0	-7/√170	11/√170	0	1	1	1	0	0	1	0	-9/√170	11/√170
0	1	0	1	0	0	1	1	-7/√170	9/√170	0	1	1	1	0	0	1	1	-9/√170	9/√170
0	1	0	1	0	1	0	0	-5/√170	13/√170	0	1	1	1	0	1	0	0	-11/√170	13/√170
0	1	0	1	0	1	0	1	-5/√170	15/√170	0	1	1	1	0	1	0	1	-11/√170	15/√170
0	1	0	1	0	1	1	0	-7/√170	13/√170	0	1	1	1	0	1	1	0	-9/√170	13/√170
0	1	0	1	0	1	1	1	-7/√170	15/√170	0	1	1	1	0	1	1	1	-9/√170	15/√170
0	1	0	1	1	0	0	0	-3/√170	11/√170	0	1	1	1	1	0	0	0	-13/√170	11/√170
0	1	0	1	1	0	0	1	-3/√170	9/√170	0	1	1	1	1	0	0	1	-13/√170	9/√170
0	1	0	1	1	0	1	0	-1/√170	11/√170	0	1	1	1	1	0	1	0	-15/√170	11/√170
0	1	0	1	1	0	1	1	-1/√170	9/√170	0	1	1	1	1	0	1	1	-15/√170	9/√170
0	1	0	1	1	1	0	0	-3/√170	13/√170	0	1	1	1	1	1	0	0	-13/√170	13/√170
0	1	0	1	1	1	0	1	-3/√170	15/√170	0	1	1	1	1	1	0	1	-13/√170	15/√170
0	1	0	1	1	1	1	0	-1/√170	13/√170	0	1	1	1	1	1	1	0	-15/√170	13/√170
0	1	0	1	1	1	1	1	-1/√170	15/√170	0	1	1	1	1	1	1	1	-15/√170	15/√170

Ak	Bk	Ck	Dk	Ek	Fk	Gk	Hk	Ik	Qk	Ak	Bk	Ck	Dk	Ek	Fk	Gk	Hk	Ik	Qk
1	0	0	0	0	0	0	0	5/√170	-5/√170	1	0	1	0	0	0	0	0	11/√170	-5/√170
1	0	0	0	0	0	0	1	5/√170	-7/√170	1	0	1	0	0	0	0	1	11/√170	-7/√170
1	0	0	0	0	0	1	0	7/√170	-5/√170	1	0	1	0	0	0	1	0	9/√170	-5/√170
1	0	0	0	0	0	1	1	7/√170	-7/√170	1	0	1	0	0	0	1	1	9/√170	-7/√170
1	0	0	0	0	1	0	0	5/√170	-3/√170	1	0	1	0	0	1	0	0	11/√170	-3/√170
1	0	0	0	0	1	0	1	5/√170	-1/√170	1	0	1	0	0	1	0	1	11/√170	-1/√170
1	0	0	0	0	1	1	0	7/√170	-3/√170	1	0	1	0	0	1	1	0	9/√170	-3/√170
1	0	0	0	0	1	1	1	7/√170	-1/√170	1	0	1	0	0	1	1	1	9/√170	-1/√170
1	0	0	0	1	0	0	0	3/√170	-5/√170	1	0	1	0	1	0	0	0	13/√170	-5/√170
1	0	0	0	1	0	0	1	3/√170	-7/√170	1	0	1	0	1	0	0	1	13/√170	-7/√170
1	0	0	0	1	0	1	0	1/√170	-5/√170	1	0	1	0	1	0	1	0	15/√170	-5/√170
1	0	0	0	1	0	1	1	1/√170	-7/√170	1	0	1	0	1	0	1	1	15/√170	-7/√170
1	0	0	0	1	1	0	0	3/√170	-3/√170	1	0	1	0	1	1	0	0	13/√170	-3/√170
1	0	0	0	1	1	0	1	3/√170	-1/√170	1	0	1	0	1	1	0	1	13/√170	-1/√170
1	0	0	0	1	1	1	0	1/√170	-3/√170	1	0	1	0	1	1	1	0	15/√170	-3/√170
1	0	0	0	1	1	1	1	1/√170	-1/√170	1	0	1	0	1	1	1	1	15/√170	-1/√170
1	0	0	1	0	0	0	0	5/√170	-11/√170	1	0	1	1	0	0	0	0	11/√170	-11/√170
1	0	0	1	0	0	0	1	5/√170	-9/√170	1	0	1	1	0	0	0	1	11/√170	-9/√170
1	0	0	1	0	0	1	0	7/√170	-11/√170	1	0	1	1	0	0	1	0	9/√170	-11/√170
1	0	0	1	0	0	1	1	7/√170	-9/√170	1	0	1	1	0	0	1	1	9/√170	-9/√170
1	0	0	1	0	1	0	0	5/√170	-13/√170	1	0	1	1	0	1	0	0	11/√170	-13/√170
1	0	0	1	0	1	0	1	5/√170	-15/√170	1	0	1	1	0	1	0	1	11/√170	-15/√170
1	0	0	1	0	1	1	0	7/√170	-13/√170	1	0	1	1	0	1	1	0	9/√170	-13/√170
1	0	0	1	0	1	1	1	7/√170	-15/√170	1	0	1	1	0	1	1	1	9/√170	-15/√170
1	0	0	1	1	0	0	0	3/√170	-11/√170	1	0	1	1	1	0	0	0	13/√170	-11/√170
1	0	0	1	1	0	0	1	3/√170	-9/√170	1	0	1	1	1	0	0	1	13/√170	-9/√170
1	0	0	1	1	0	1	0	1/√170	-11/√170	1	0	1	1	1	0	1	0	15/√170	-11/√170
1	0	0	1	1	0	1	1	1/√170	-9/√170	1	0	1	1	1	0	1	1	15/√170	-9/√170
1	0	0	1	1	1	0	0	3/√170	-13/√170	1	0	1	1	1	1	0	0	13/√170	-13/√170
1	0	0	1	1	1	0	1	3/√170	-15/√170	1	0	1	1	1	1	0	1	13/√170	-15/√170
1	0	0	1	1	1	1	0	1/√170	-13/√170	1	0	1	1	1	1	1	0	15/√170	-13/√170
1	0	0	1	1	1	1	1	1/√170	-15/√170	1	0	1	1	1	1	1	1	15/√170	-15/√170

Ak	Bk	Ck	Dk	Ek	Fk	Gk	Hk	Ik	Qk	Ak	Bk	Ck	Dk	Ek	Fk	Gk	Hk	Ik	Qk
1	1	0	0	0	0	0	0	5/√170	5/√170	1	1	1	0	0	0	0	0	11/√170	5/√170
1	1	0	0	0	0	0	1	5/√170	7/√170	1	1	1	0	0	0	0	1	11/√170	7/√170
1	1	0	0	0	0	1	0	7/√170	5/√170	1	1	1	0	0	0	1	0	9/√170	5/√170
1	1	0	0	0	0	1	1	7/√170	7/√170	1	1	1	0	0	0	1	1	9/√170	7/√170
1	1	0	0	0	1	0	0	5/√170	3/√170	1	1	1	0	0	1	0	0	11/√170	3/√170
1	1	0	0	0	1	0	1	5/√170	1/√170	1	1	1	0	0	1	0	1	11/√170	1/√170
1	1	0	0	0	1	1	0	7/√170	3/√170	1	1	1	0	0	1	1	0	9/√170	3/√170
1	1	0	0	0	1	1	1	7/√170	1/√170	1	1	1	0	0	1	1	1	9/√170	1/√170
1	1	0	0	1	0	0	0	3/√170	5/√170	1	1	1	0	1	0	0	0	13/√170	5/√170
1	1	0	0	1	0	0	1	3/√170	7/√170	1	1	1	0	1	0	0	1	13/√170	7/√170
1	1	0	0	1	0	1	0	1/√170	5/√170	1	1	1	0	1	0	1	0	15/√170	5/√170
1	1	0	0	1	0	1	1	1/√170	7/√170	1	1	1	0	1	0	1	1	15/√170	7/√170
1	1	0	0	1	1	0	0	3/√170	3/√170	1	1	1	0	1	1	0	0	13/√170	3/√170
1	1	0	0	1	1	0	1	3/√170	1/√170	1	1	1	0	1	1	0	1	13/√170	1/√170
1	1	0	0	1	1	1	0	1/√170	3/√170	1	1	1	0	1	1	1	0	15/√170	3/√170
1	1	0	0	1	1	1	1	1/√170	1/√170	1	1	1	0	1	1	1	1	15/√170	1/√170
1	1	0	1	0	0	0	0	5/√170	11/√170	1	1	1	1	0	0	0	0	11/√170	11/√170
1	1	0	1	0	0	0	1	5/√170	9/√170	1	1	1	1	0	0	0	1	11/√170	9/√170
1	1	0	1	0	0	1	0	7/√170	11/√170	1	1	1	1	0	0	1	0	9/√170	11/√170
1	1	0	1	0	0	1	1	7/√170	9/√170	1	1	1	1	0	0	1	1	9/√170	9/√170
1	1	0	1	0	1	0	0	5/√170	13/√170	1	1	1	1	0	1	0	0	11/√170	13/√170
1	1	0	1	0	1	0	1	5/√170	15/√170	1	1	1	1	0	1	0	1	11/√170	15/√170
1	1	0	1	0	1	1	0	7/√170	13/√170	1	1	1	1	0	1	1	0	9/√170	13/√170
1	1	0	1	0	1	1	1	7/√170	15/√170	1	1	1	1	0	1	1	1	9/√170	15/√170
1	1	0	1	1	0	0	0	3/√170	11/√170	1	1	1	1	1	0	0	0	13/√170	11/√170
1	1	0	1	1	0	0	1	3/√170	9/√170	1	1	1	1	1	0	0	1	13/√170	9/√170
1	1	0	1	1	0	1	0	1/√170	11/√170	1	1	1	1	1	0	1	0	15/√170	11/√170
1	1	0	1	1	0	1	1	1/√170	9/√170	1	1	1	1	1	0	1	1	15/√170	9/√170
1	1	0	1	1	1	0	0	3/√170	13/√170	1	1	1	1	1	1	0	0	13/√170	13/√170
1	1	0	1	1	1	0	1	3/√170	15/√170	1	1	1	1	1	1	0	1	13/√170	15/√170
1	1	0	1	1	1	1	0	1/√170	13/√170	1	1	1	1	1	1	1	0	15/√170	13/√170
1	1	0	1	1	1	1	1	1/√170	15/√170	1	1	1	1	1	1	1	1	15/√170	15/√170

(2) The signal space diagram is shown in figure below.

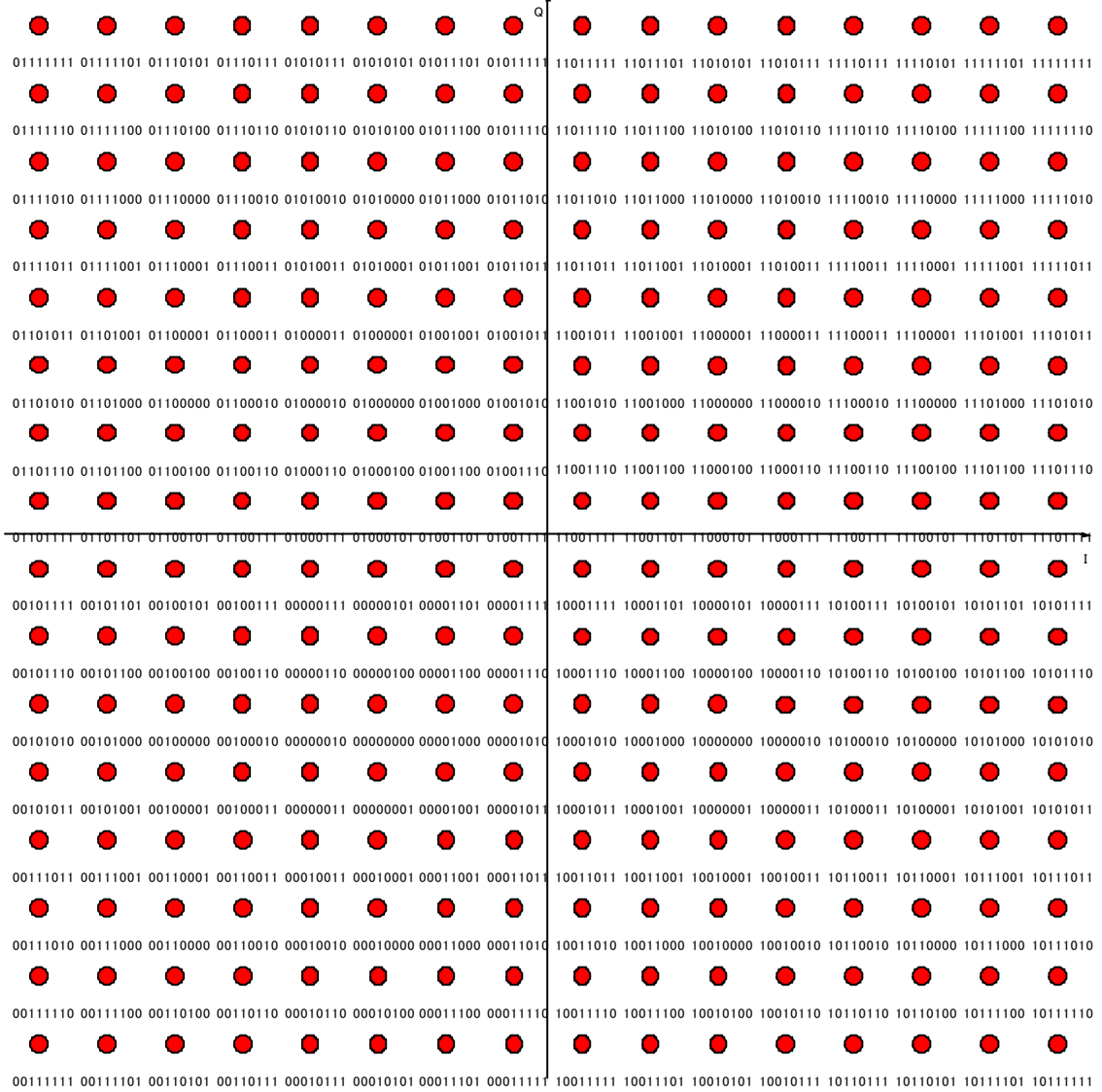

Figure B.8 256QAM

B.9 16PSK

The signal space diagram for 16PSK is shown in Figure B.9. 16PSK is only used for training sequences for SC.

Ak	Ik	Qk
a	1	0
b	0.923879533	0.382683432
c	0.707106781	0.707106781
d	0.382683432	0.923879533
e	0	1
f	-0.382683432	0.923879533
g	-0.707106781	0.707106781
h	-0.923879533	0.382683432
i	-1	0
j	-0.923879533	-0.382683432
k	-0.707106781	-0.707106781
l	-0.382683432	-0.923879533
m	0	-1
n	0.382683432	-0.923879533
o	0.707106781	-0.707106781
p	0.923879533	-0.382683432

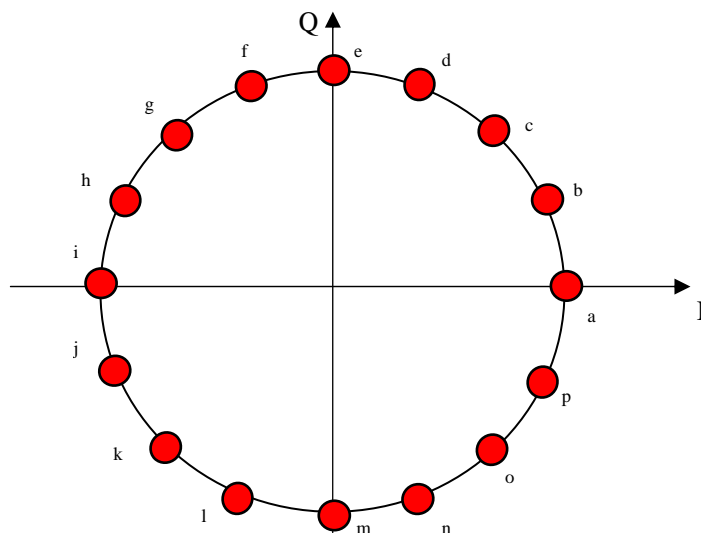

Figure B.9 16PSK

Appendix C: Training Sequence

C.1 OFDM Training Sequence

The training sequence for OFDM is shown in Table C.1, Table C.2 and Table C.3. These tables are referred to in Section 3.4.2.

Table C.1 Training Pattern (1 – 4)

Subcarrier Number	Core-Sequence							
	Core-Seq 1		Core-Seq 2		Core-Seq 3		Core-Seq 4	
	I	Q	I	Q	I	Q	I	Q
1	0	0	0	0	0	0	0	0
2	-1	1	-1	1	1	-1	1	1
3	1	1	-1	1	1	-1	1	-1
4	1	1	-1	1	-1	-1	1	-1
5	-1	1	-1	-1	1	-1	-1	-1
6	-1	-1	-1	1	1	-1	-1	1
7	1	1	1	1	1	1	-1	-1
8	-1	1	1	-1	-1	1	-1	1
9	1	1	-1	1	1	1	-1	-1
10	-1	-1	1	-1	1	-1	-1	-1
11	1	-1	-1	1	-1	1	-1	1
12	1	-1	-1	-1	1	-1	1	-1
13	0	0	0	0	0	0	0	0
14	-1	-1	-1	1	1	1	-1	1
15	1	1	1	1	-1	1	1	-1
16	1	-1	1	1	-1	1	-1	1
17	-1	-1	-1	1	1	1	-1	1
18	1	1	-1	-1	1	-1	-1	1
19	1	1	1	1	-1	1	-1	1
20	-1	-1	-1	1	1	-1	1	1
21	1	-1	1	1	1	-1	-1	-1
22	-1	1	-1	-1	-1	-1	1	-1
23	1	1	1	-1	1	-1	-1	1
24	-1	1	1	-1	1	1	-1	1

Note: In case of QPSK, $1 \rightarrow 1/\sqrt{2}$, $-1 \rightarrow -1/\sqrt{2}$

Table C.2 Training Pattern (5 - 8)

Subcarrier Number	Core-Sequence							
	Core-Seq 5		Core-Seq 6		Core-Seq 7		Core-Seq 8	
	I	Q	I	Q	I	Q	I	Q
1	0	0	0	0	0	0	0	0
2	1	1	-1	-1	1	1	1	-1
3	-1	1	-1	-1	1	1	-1	1
4	-1	1	1	-1	-1	-1	-1	-1
5	1	1	-1	1	1	-1	-1	-1
6	1	-1	-1	-1	1	-1	1	-1
7	-1	1	1	1	-1	-1	1	-1
8	1	-1	1	-1	1	1	1	-1
9	1	-1	-1	1	1	1	-1	-1
10	-1	-1	1	-1	1	1	-1	1
11	1	-1	1	-1	-1	-1	1	1
12	1	1	-1	-1	-1	1	-1	-1
13	0	0	0	0	0	0	0	0
14	1	1	1	1	1	-1	-1	1
15	1	-1	1	-1	1	-1	-1	1
16	1	1	1	-1	-1	-1	-1	1
17	1	-1	-1	-1	1	-1	-1	-1
18	-1	-1	-1	1	1	-1	-1	1
19	1	1	-1	-1	1	1	1	1
20	1	1	-1	1	-1	1	1	-1
21	1	-1	-1	-1	1	1	-1	1
22	1	1	-1	-1	1	-1	1	-1
23	-1	-1	-1	1	-1	1	-1	1
24	1	-1	1	-1	1	-1	-1	-1

Note: In case of QPSK, $1 \rightarrow 1/\sqrt{2}$, $-1 \rightarrow -1/\sqrt{2}$

Table C.3 Training Pattern (9 – 12)

Subcarrier Number	Core-Sequence							
	Core-Seq 9		Core-Seq 10		Core-Seq 11		Core-Seq 12	
	I	Q	I	Q	I	Q	I	Q
1	0	0	0	0	0	0	0	0
2	-1	-1	-1	-1	-1	-1	-1	1
3	1	-1	1	-1	1	1	1	-1
4	1	1	-1	-1	1	-1	-1	1
5	1	-1	1	-1	-1	-1	-1	1
6	-1	1	-1	1	1	1	-1	1
7	1	1	-1	1	1	1	-1	1
8	-1	1	1	1	-1	-1	1	1
9	-1	-1	1	1	1	-1	-1	-1
10	1	-1	-1	1	-1	1	1	-1
11	-1	-1	-1	1	1	1	-1	1
12	-1	1	1	-1	-1	1	-1	1
13	0	0	0	0	0	0	0	0
14	1	1	1	-1	-1	-1	1	1
15	1	-1	-1	1	1	-1	1	-1
16	-1	1	-1	-1	-1	-1	-1	1
17	-1	1	-1	-1	1	-1	-1	-1
18	1	1	1	-1	-1	1	1	1
19	-1	-1	1	-1	-1	1	-1	1
20	1	1	1	-1	1	1	-1	1
21	1	1	-1	-1	1	1	1	-1
22	-1	-1	-1	1	-1	1	1	-1
23	1	-1	1	1	-1	1	1	-1
24	-1	-1	-1	-1	1	-1	1	1

Note: In case of QPSK, $1 \rightarrow 1/\sqrt{2}$, $-1 \rightarrow -1/\sqrt{2}$

Offset value for OFDM training sequence is shown in Table C.4. This table is referred to in Section 3.4.2.

Table C.4 Offset Value for OFDM Training Sequence

System Bandwidth [MHz]	2.5	5	10	20
FFT Size	64	128	256	512
Offset Value 1(X sample)	0	0	0	0
Offset Value 2(X sample)	32	64	128	256
Offset Value 3(X sample)		32	64	128
Offset Value 4(X sample)		96	192	384
Offset Value 5(X sample)			32	64
Offset Value 6(X sample)			96	192
Offset Value 7(X sample)			160	320
Offset Value 8(X sample)			224	448
Offset Value 9(X sample)			16	32
Offset Value 10(X sample)			48	96
Offset Value 11(X sample)				160
Offset Value 12(X sample)				224
Offset Value 13(X sample)				288
Offset Value 14(X sample)				352
Offset Value 15(X sample)				416
Offset Value 16(X sample)				480
Offset Value 17(X sample)				16
Offset Value 18(X sample)				48
Offset Value 19(X sample)				80
Offset Value 20(X sample)				112

Training signals of the offset value are calculated by following equation.

$$\theta = 2\pi \times (\text{SubcarrierNumber}[1 \text{ to } 24] - 13) \times \text{Offsetvalue} / \text{FFTsize} \quad (\text{C.1})$$

$$(I, Q) = (I_{\text{Core-Seq}}, Q_{\text{Core-Seq}}) \times (\cos\theta, \sin\theta)$$

For example, Table C.5 shows the calculated results when core-sequence number is 1 and FFT size is 512 and offset sample is 128.

Table C.5 The Calculated Example When Core-sequence Number is 1, FFT Size Is 512 and Offset Sample is 128

Subcarrier Number	Core-Sequence		Using Guard Carrier		Offset Sample 128	
	Core-Seq 1		I	Q	I	Q
	I	Q	I	Q	I	Q
1	0	0	1	-1	1	-1
2	-1	1	-1	1	-1	-1
3	1	1	1	1	-1	-1
4	1	1	1	1	1	-1
5	-1	1	-1	1	-1	1
6	-1	-1	-1	-1	1	-1
7	1	1	1	1	-1	-1
8	-1	1	-1	1	1	1
9	1	1	1	1	1	1
10	-1	-1	-1	-1	1	-1
11	1	-1	1	-1	-1	1
12	1	-1	1	-1	-1	-1
13	0	0	0	0	0	0
14	-1	-1	-1	-1	1	-1
15	1	1	1	1	-1	-1
16	1	-1	1	-1	-1	-1
17	-1	-1	-1	-1	-1	-1
18	1	1	1	1	-1	1
19	1	1	1	1	-1	-1
20	-1	-1	-1	-1	-1	1
21	1	-1	1	-1	1	-1
22	-1	1	-1	1	-1	-1
23	1	1	1	1	-1	-1
24	-1	1	-1	1	1	1

Note: In this case, "1" => " $1/\sqrt{2}$ ", "-1" => " $-1/\sqrt{2}$ "

As shown in Table C.5, if guard carrier with subcarrier number 1 is used, it will be copied to subcarrier number 12 of core-sequence. Then, this calculation is carried out per PRU.

C.2 SC Training Sequence

Training sequences of the length when N is 16 for the pilot block S9 of CSCH are shown in Table C.6. This is also referred to in Section 3.6.2. Training sequences of the length when N is 16 are shown in Table C.7. Parameters to generate training sequences for N as 32, 64, 128 and 256 are shown in Table C.8 to Table C.11, respectively. Using these parameters, training sequence of length N, $[t(1), t(2), \dots, t(n), \dots, t(N)]$, is defined as follows:

$$t(n) = \exp(j\pi r((n-1)^2 - k^2)/N) * b(k+1) \quad (C.2)$$

,where $k = (n-1) \text{ MOD } m$

Training sequences for SC are referred to in Section 3.6.2.

Table C.6 Training Sequence for Pilot with Signal of CSCH (N=16)

Symbol Number	Core-Sequence Number							
	1	2	3	4	5	6	7	8
1	A0	A0	A0	A0	A0	A0	A0	A0
2	A1	A1	A1	A1	A0	A0	A0	A0
3	A0	A0	A2	A4	A1	A1	A5	A5
4	A3	A7	A5	A3	A3	A7	A3	A7
5	A4	A4	A0	A4	A6	A6	A6	A6
6	A1	A1	A5	A1	A2	A2	A2	A2
7	A4	A4	A2	A0	A7	A7	A3	A3
8	A3	A7	A1	A3	A5	A1	A5	A1
9	A0	A0	A0	A0	A4	A4	A4	A4
10	A1	A1	A1	A1	A4	A4	A4	A4
11	A0	A0	A2	A4	A5	A5	A1	A1
12	A3	A7	A5	A3	A7	A3	A7	A3
13	A4	A4	A0	A4	A2	A2	A2	A2
14	A1	A1	A5	A1	A6	A6	A6	A6
15	A4	A4	A2	A0	A3	A3	A7	A7
16	A3	A7	A1	A3	A1	A5	A1	A5

Note: A_i is on the 8PSK constellation. $A_i = \exp(j\pi * i/4)$

Table C.7 Training Sequence (N=16)

Symbol Number	Core-Sequence Number							
	1	2	3	4	5	6	7	8
1	A0	A0	A0	A0	A0	A0	A0	A0
2	A1	A1	A1	A1	A1	A1	A1	A1
3	A0	A0	A0	A0	A0	A0	A0	A0
4	A1	A1	A1	A1	A1	A1	A5	A5
5	A0	A0	A0	A0	A0	A0	A0	A0
6	A3	A3	A5	A5	A7	A7	A3	A3
7	A4	A6	A2	A6	A2	A4	A4	A6
8	A7	A5	A7	A3	A5	A3	A3	A1
9	A0	A0	A0	A0	A0	A0	A0	A0
10	A5	A5	A1	A1	A5	A5	A5	A5
11	A0	A4	A4	A4	A4	A0	A0	A4
12	A5	A1	A5	A5	A1	A5	A1	A5
13	A0	A0	A0	A0	A0	A0	A0	A0
14	A7	A7	A5	A5	A3	A3	A7	A7
15	A4	A2	A6	A2	A6	A4	A4	A2
16	A3	A5	A3	A7	A5	A7	A7	A1

Note: A_i is on the 8PSK constellation. $A_i = \exp(j\pi*i/4)$

Table C.8 Training Sequence (N=32)

Parameters	Core-Sequence Number							
	1	2	3	4	5	6	7	8
m	4	4	4	4	4	4	4	4
r	1	1	3	3	5	5	7	7
b(1)	A0	A0	A0	A0	A0	A0	A0	A0
b(2)	A0	A0	A0	A0	A0	A0	A0	A0
b(3)	A0	A0	A0	A0	A0	A0	A0	A0
b(4)	A0	A4	A0	A4	A0	A4	A0	A4

Note: A_i is on the 8PSK constellation. $A_i = \exp(j\pi*i/4)$

Table C.9 Training Sequence (N=64)

Parameters	Core-Sequence Number							
	1	2	3	4	5	6	7	8
m	8	8	8	8	8	8	8	8
r	1	1	3	3	5	5	7	7
b(1)	A0	A0	A0	A0	A0	A0	A0	A0
b(2)	A0	A0	A0	A0	A0	A0	A0	A0
b(3)	A0	A0	A0	A0	A0	A0	A0	A0
b(4)	A0	A2	A0	A2	A0	A2	A0	A2
b(5)	A0	A4	A0	A4	A0	A4	A0	A4
b(6)	A0	A0	A0	A0	A0	A0	A0	A0
b(7)	A0	A4	A0	A4	A4	A0	A4	A0
b(8)	A0	A2	A0	A2	A0	A2	A0	A2

Note: A_i is on the 8PSK constellation. $A_i = \exp(j\pi*i/4)$

Table C.10 Training Sequence (N=128)

Parameters	Core-Sequence Number							
	1	2	3	4	5	6	7	8
m	8	8	8	8	8	8	8	8
r	1	3	5	7	9	11	13	15
b(1)	A0	A0	A0	A0	A0	A0	A0	A0
b(2)	A0	A0	A0	A0	A0	A0	A0	A0
b(3)	A0	A0	A0	A0	A0	A0	A0	A0
b(4)	A0	A0	A0	A0	A0	A0	A0	A0
b(5)	A0	A0	A0	A0	A0	A0	A0	A0
b(6)	A0	A0	A0	A0	A0	A0	A0	A0
b(7)	A0	A0	A0	A0	A8	A8	A8	A8
b(8)	A0	A0	A0	A0	A0	A0	A0	A0

Note: A_i is on the 16PSK constellation. $A_i = \exp(j\pi*i/8)$

Table C.11 Training Sequence (N=256)

Parameters	Core-Sequence Number							
	1	2	3	4	5	6	7	8
m	16	16	16	16	16	16	16	16
r	1	3	5	7	9	11	13	15
b(1)	A0	A0	A0	A0	A0	A0	A0	A0
b(2)	A0	A0	A0	A0	A0	A0	A0	A0
b(3)	A0	A0	A0	A0	A0	A0	A0	A0
b(4)	A0	A0	A0	A0	A0	A0	A0	A0
b(5)	A0	A0	A0	A0	A0	A0	A0	A0
b(6)	A0	A0	A0	A0	A0	A0	A0	A0
b(7)	A0	A0	A0	A0	A0	A0	A0	A0
b(8)	A0	A0	A0	A0	A0	A0	A0	A0
b(9)	A0	A0	A0	A0	A0	A0	A0	A0
b(10)	A0	A0	A0	A0	A4	A4	A4	A4
b(11)	A0	A0	A0	A0	A8	A8	A8	A8
b(12)	A0	A0	A0	A0	A0	A0	A0	A0
b(13)	A0	A0	A0	A0	A12	A12	A12	A12
b(14)	A0	A0	A0	A0	A4	A4	A4	A4
b(15)	A0	A0	A0	A0	A8	A8	A8	A8
b(16)	A0	A0	A0	A0	A8	A8	A8	A8

Note: A_i is on the 16PSK constellation. $A_i = \exp(j\pi*i/8)$

Offset value for SC training sequence is shown in Table C.12. This table is referred to in Section 3.6.2.

Table C.12 Offset Value for SC Training Sequence

Sequence Size: N [symbol]	16	16	32	64	128	256
	(Table C.6)	(Table C.7)				
Offset Value 1 [symbol]	0	0	0	0	0	0
Offset Value 2 [symbol]	4	8	16	32	64	128
Offset Value 3 [symbol]	2	4	8	16	32	64
Offset Value 4 [symbol]	6	12	24	48	96	192
Offset Value 5 [symbol]				8	16	32
Offset Value 6 [symbol]				40	80	160
Offset Value 7 [symbol]				24	48	96
Offset Value 8 [symbol]				56	112	224

Appendix D: TCCH Sequence

D.1 OFDM TCCH Sequence

TCCH sequence for OFDM is shown in Table D.1. This table is referred to in Sections 3.5.6 and 3.5.7.

Table D.1 TCCH Sequence for OFDM

Subcarrier Number	TCCH Sequence Number for OFDM					
	1	2	3	4	5	6
1	0	0	0	0	0	0
2	A7	A1	A5	A7	A7	A3
3	A5	A1	A3	A5	A7	A5
4	A1	A3	A5	A7	A5	A1
5	A3	A1	A5	A1	A3	A3
6	A1	A3	A7	A7	A7	A5
7	A3	A5	A7	A5	A3	A7
8	A5	A1	A5	A1	A3	A5
9	A1	A7	A3	A3	A5	A3
10	A5	A1	A5	A7	A3	A7
11	A5	A5	A5	A5	A3	A1
12	A7	A7	A7	A3	A1	A7
13	0	0	0	0	0	0
14	A7	A5	A7	A7	A3	A7
15	A1	A3	A7	A3	A1	A3
16	A5	A7	A1	A1	A3	A5
17	A7	A5	A5	A7	A7	A1
18	A7	A7	A1	A7	A1	A3
19	A1	A1	A1	A7	A5	A3
20	A1	A1	A7	A1	A5	A5
21	A1	A1	A7	A3	A5	A3
22	A3	A3	A3	A3	A5	A3
23	A1	A1	A5	A5	A7	A3
24	A3	A1	A7	A7	A3	A1

Note: A_i is on the QPSK constellation. $A_i = \exp(j\pi*i/4)$

D.2 SC TCCH sequence

TCCH sequence for SC is shown in Table D.2. This table is referred to in Section 3.6.5.

Table D.2 TCCH Sequence for SC

Symbol Number	Core-Sequence Number					
	1	2	3	4	5	6
1	A0	A0	A0	A0	A0	A0
2	A1	A1	A1	A1	A1	A1
3	A0	A0	A0	A0	A0	A0
4	A1	A1	A1	A1	A1	A1
5	A0	A0	A0	A0	A0	A0
6	A3	A3	A5	A5	A7	A7
7	A4	A6	A2	A6	A2	A4
8	A7	A5	A7	A3	A5	A3
9	A0	A0	A0	A0	A0	A0
10	A5	A5	A1	A1	A5	A5
11	A0	A4	A4	A4	A4	A0
12	A5	A1	A5	A5	A1	A5
13	A0	A0	A0	A0	A0	A0
14	A7	A7	A5	A5	A3	A3
15	A4	A2	A6	A2	A6	A4
16	A3	A5	A3	A7	A5	A7

Note: A_i is on the 8PSK constellation. $A_i = \exp(j\pi*i/4)$